



Midway Metals

the stainless steel innovators

PRODUCTS & SERVICES CATALOGUE

11TH EDITION



**AUSTRALIA'S LARGEST
INDEPENDENT
STAINLESS STOCKISTS**

HEAD OFFICE & COIL CENTRE

Street: 56 Business Street YATALA QLD 4207
Postal: PO Box 621 BEENLEIGH QLD 4207 AUSTRALIA

P (07) 3382 9500 | **F** (07) 3807 8150
E headoffice@midwaymetals.com.au

ALBURY

Prospero Court ALBURY NSW 2640
P (02) 6041 4000 | **F** (02) 6041 4422
E albury@midwaymetals.com.au

BRISBANE

56 Business Street YATALA QLD 4207
P (07) 3287 2811 | **F** (07) 3807 2687
E brisbane@midwaymetals.com.au

MELBOURNE

33 Tatterson Road DANDENONG VIC 3175
P (03) 9791 5111 | **F** (03) 9791 5333
E melbourne@midwaymetals.com.au

NEWCASTLE

12 Sandringham Avenue THORNTON NSW 2322
P (02) 4966 3800 | **F** (02) 4966 3811
E newcastle@midwaymetals.com.au

PERTH

471 Victoria Road MALAGA WA 6090
P (08) 9248 6944 | **F** (08) 9248 6955
E perth@midwaymetals.com.au

SYDNEY

24-28 Lockwood Road, ERSKINE PARK NSW 2759
P (02) 9670 8900 | **F** (02) 9834 2441
E sydney@midwaymetals.com.au

TOWNSVILLE

331-335 Woolcock Street GARBUTT QLD 4814
P (07) 4728 8777 | **F** (07) 4728 8778
E townsville@midwaymetals.com.au

AUCKLAND

P +64 9 424 4194 | **F** +64 9 424 4194
E auckland@midwaymetals.com.au

VIETNAM

P +84 3 5184 8468 | **F** +84 3 5184 8456
E info@midwaymetals.com.vn

www.midwaymetals.com.au

ABN: 88 001 831 090

DISCLAIMER

The technical information contained in this publication should not be relied on for specific applications without first securing competent advice. Whilst all care is taken to ensure that the information contained herein is accurate and up-to-date, Midway Metals Pty Ltd does not warrant its accuracy or completeness and does not accept liability for errors or omissions.

COPYRIGHT

All rights reserved. No part of this publication may be reproduced or distributed in any form or by any means, or stored in a database or retrieval system, without prior written permission of Midway Metals.

TABLE OF CONTENTS

INTRODUCTION

COMPANY PROFILE	3
SERVICES	3

BLANKING LINE

BLANKING LINE	4-5
FLAT BAR LINE	6
SLITTING LINE	6-7

FLAT PRODUCTS

COIL	8
SHEET	9-10
PERFORATED SHEET	11
WELDED AND WOVEN MESH	12
PLATE	13-14
FLOOR PLATE / COIL	15
PLASMA / PROCESSING FACILITIES	16-17

BAR PRODUCTS

ROUND BAR	18-19
ROUND BAR TECHNICAL DATA	20
FLAT BAR	21-22
ANGLE BAR	23
HEXAGON BAR	24
HOLLOW BAR	25-26
SQUARE BAR	27
FLAT, SQUARE, HEXAGON & ANGLE BAR TECHNICAL DATA	28
CHANNEL	29
CHANNEL TECHNICAL DATA	30

PIPE PRODUCTS

SEAMLESS & WELDED PIPE	21-32
PIPE TECHNICAL DATA	33-34
BUTTWELD PIPE FITTINGS	35
REDUCING BUTTWELD PIPE FITINGS	36
BUTTWELD PIPE FITTINGS TECHNICAL DATA	37-38
150LB BSP THREADED FITTINGS	39
150LB BSP THREADED FITTINGS TECHNICAL DATA	40-41
3000LB NPT THREADED FITTINGS	42
3000LB SOCKETWELD FITTINGS	42
3000LB NPT THREADED FITTINGS TECHNICAL DATA	43-44
3000LB SOCKETWELD FITTINGS TECHNICAL DATA	45
FORGED FLANGES	46
FORGED FLANGES TECHNICAL DATA	47
PLATE FLANGES	48
PLATE FLANGES TECHNICAL DATA	49-50

LEGEND

★ STANDARD STOCK LINE

☆ AVAILABLE ON REQUEST

TABLE OF CONTENTS

TUBE PRODUCTS

WELDED ROUND TUBE	51
ARCHITECTURAL TUBE	52
WELDED SQUARE & RECTANGULAR TUBE	53
TUBE FITTINGS	54
REDUCING TUBE FITTINGS	55
TUBE FITTINGS TECHNICAL DATA	56-57
HYGIENIC FITTINGS	58
HYGIENIC FITTINGS TECHNICAL DATA	59-60
TRICLOVER FITTINGS TECHNICAL DATA	61
VALVES & EQUIPMENT	62
PLATE FLANGES	63
PLATE FLANGES TECHNICAL DATA	64
SEAMLESS TUBE	65
SEAMLESS/WELDED TUBE TECHNICAL DATA	66
COMPRESSION FITTINGS	67
AUXILIARY TUBE FITTINGS	68
FACE RINGS	68
EXPANSION FLANGES	69
HD A-JUSTA-FOOT	70
A-JUSTA-FOOT	71-72

WELDING CONSUMABLES AND FINISHING PRODUCTS

COVERED ELECTRODES	73-74
SOLID WIRES	75-76
FLUX COLOURED WIRES	77
PICKLING AND CLEANING CHEMICALS	78

VALVES

1 PIECE 800 WOG BALL VALVE - THREADED	79
2 PIECE 1000 WOG BALL VALVE - THREADED	80
3 PIECE 1000 WOG BALL VALVE - THREADED	81
3 WAY REDUCED PORT 1000 WOG BALL VALVE - THREADED 'L' PORT	82
3 WAY REDUCED PORT 1000 WOG BALL VALVE - THREADED 'T' PORT	83
200 WOG SWING CHECK VALVE	84
800 WOG Y STRAINER	84
1000 WOG SPRING CHECK VALVE	85

TECHNICAL DATA

PRESSURE CONVERSIONS	86
USEFUL CONVERSION FACTORS	87
STAINLESS STEEL GRADES	88-90
CORROSION CHART	91-93
GLOSSARY	94-97

LEGEND

★ STANDARD STOCK LINE

☆ AVAILABLE ON REQUEST

COMPANY PROFILE

Midway Metals is a wholly owned Australian company, and is Australia's largest independent Stainless Steel Stockist. We offer a complete range of stainless steel.

We pride ourselves on being at the forefront of innovation in both product lines and services, and we will constantly upgrade our products and services to meet market expectations and demands.

Midway Metals operates from seven locations in Australia with branches also in New Zealand and Vietnam.

Our main focus is ensuring complete customer satisfaction via procuring, stocking and identifying all forms of stainless steels and providing an unequalled level of after sales service.

At Midway Metals our strengths lie in our personnel and our service. These two key areas of our business promote our mission statement:

"SERVICE EXCELLENCE THROUGH UNDERSTANDING THE NEEDS OF OUR INDUSTRY".

Through our worldwide network of mills and suppliers we strive to offer a quality product at a competitive price whether it be from stock, ex-mill delivery or an indent programmed delivery.

SERVICE

- 24 hour breakdown service / 24 hour paging system.
- Material identification transfer. Workplace health and safety accreditation for material identification / heat number transfer.
- Technical and advisory service.
- Contract supply, ensuring delivery of material on time every time.
- Project management assistance/indent facilities.
- Cut to size.



THE STAINLESS STEEL INNOVATORS

Leading the industry in both quality and innovation of product lines and services, is our main priority. We are constantly updating what we offer to ensure that we stay ahead of our competitors. We go the extra mile to meet our customers needs. Midway's focus is ensuring complete customer satisfaction via procuring, stocking and identifying all forms of stainless steel and providing an unequalled level of after sale service and support.

NOT JUST PRODUCTS

At Midway, we don't just sell stainless steel. We have a whole range of services that set us apart from our competitors and further reinforces our position as the industry leaders in all things stainless steel. We are passionate about meeting your needs and will continue to deliver on our promise to lead the industry in quality, service and innovation.

BLANKING LINE

ABSOLUTELY LASER FLAT

At Midway Metals, we pride ourselves on quality and innovation. We're constantly upgrading our products and services to meet and exceed market expectations. We are proud to announce that we have made the largest investment in the stainless steel industry in Australia since the mid 1990's.

Laser cutters and fabricators demand flat material and Midway Metals can deliver. We have recently purchased and installed a state of the art precision blanking line from Red Bud in the US, with an in-line stretcher leveller, that produces superior flatness unsurpassed in our industry.

By stretching the material beyond its yield point, our stretcher leveller resets the material's memory from the milling process. The material is stretched from top to

bottom and edge to edge, releasing all internal stresses and producing a perfectly flat product.

Stretcher levelling is superior to other techniques currently used in Australia. It's the only process guaranteed to flatten the material, without reducing the thickness (a common problem with temper passing). And, while temper passing and roller levelling can reduce the internal stresses in the material, they will not reset it. Only stretcher levelling can reset a material's memory.

With our new precision blanking line, we can provide dead flat sheets and plates, cut to length up to 12 metres.



When precision cutting, quality fabricating and 100% perfection in flatness count, Midway Metals' stretcher leveller is the only process in Australia that can deliver.

KEY FEATURES & BENEFITS

The ability to produce perfectly flat material is not the only benefit of Midway Metals stretcher leveller technology. See below the various features and benefits that set stretcher levelling apart from other inferior alternatives.

BENEFITS FOR FABRICATORS

- Material stays flat after folding and punching
- Need for rework from warping is eliminated
- No tensile springback. Fold/bend material just once to achieve desired angle
- Save time from unnecessary rework
- Process will not change mechanical properties

BENEFITS FOR LASER CUTTERS

- Midway's Laser Flat material
- Material doesn't warp when laser cut with high heat
- Improved material quality allows for consistent cutting
- Material stays flat after laser cutting
- Likelihood of damage to laser heads decreased when cutting
- Ability to retain accuracy when cutting long, flat lengths
- Decreased cutting time with no changes in material during the cutting process



FLAT BAR LINE

SETTING A NEW STANDARD

In accordance with our reputation as the stainless steel innovators, Midway Metals are proud to announce that we have installed a slit rolled edge, flat bar machine. We are excited about this announcement because this is the only machine of its kind in Australia, further placing Midway Metals at the forefront of the stainless steel industry.

This machine reduces lead times significantly. Using the slit band from our slitting line, this machine flattens, straightens, edges and cuts the finished bar into lengths ranging from 2-6 metres. Thanks to this machine, Midway Metals can produce any width of bar, from 20mm to 200mm. This service can be used to support you with special projects as well as ongoing and recurring needs.

Custom lengths available upon request. Contact your nearest Midway Metals office for more information.

FLAT BAR LINE CAPABILITIES

	Minimum	Maximum
Entry Coil Weight	N/A	3,000kgs
Entry Coil ID	508mm	508mm
Coil Diameter	N/A	1800mm
Width	20mm	200mm
Thickness	2.0mm	8.0mm
Flat Bar Length	2000mm	6000mm

SLITTING LINE

MARKET LEADING SPEED AND CAPABILITIES

One of the most recent additions to our processing capacity, is our high speed, coil-to-coil slitting line, from Red Budin the USA. This machine will set a new standard for performance and productivity in the Australian coil processing industry.

Our new slitting line boasts a quick and easy set up, and will decrease or even eliminate the amount of camber, usually introduced in the slitting process. This reduction will yield closer tolerances for coils slit on our machine and then processed in secondary operations.

MORE THAN SIZE

Our high speed slitting line is big — the largest of its type in Australia — but it's not just size that sets this machine apart from inferior alternatives, it's the broad range of capabilities it possesses. The ability to break down larger coils into smaller ones and the option of applying PE to either the top, bottom or both sides of the material, produces a far superior product and sets this machine apart from the rest of the Australian market.

SLITTING LINE CAPABILITIES

	Minimum	Maximum
Entry Coil Weight	2,000kg	13,600kgs
Entry Coil ID	483mm	635mm
Coil Diameter	N/A	1905mm
Thickness	0.5mm	8.0mm
Coil Width	480mm	2210mm
Slit Width	20mm	2100mm
Exit Coil Weight	13,600kg	13,600kgs
Exit Coil ID	508mm	508mm

Accuracy: +/-0.51mm

Tooling: ASKO Edgemaster shimless tooling

PE Coating available top and bottom

THREE STAGES OF SPEED AND ACCURACY

Stage One

Mandrel and automatic coil tracking system

- Mandrel drives and material along the line, to the tension stand
- Automatic coil tracking system compensates when the strip deviates from the centreline by moving in the opposite direction until the coil is centered again
- Material is then sent to the crop shear for initial square edge



Stage Two

Slitting head

- Traversing base allows the slitter to 'float' with the strip while running. This side to side adjustment is motorised
- System prevents additional camber from being introduced into the slit strips
- Slitter features:
 - Fully automatic pass line compensation
 - Automatically adjusts to different knife diameters
 - Compensates for material thickness
 - PE coating ability for both sides
- Scrap choppers cut the edge trim and conveyor system carries the scrap to bins



Stage Three

Tension system, exit crop shear and recoiler

- Automatic tension system assures proper winding tension
- Exit crop shear cuts the coil ahead of recoiler to eliminate the need for rethreading the entire line when breaking down coils
- Mandrel gripper compensates for thickness variations across the width of the strip
- Recoiler tail hold-downs and controls strips, which prevents loose tails at the end of the run



SPECIFICATIONS: ASTM A240/480

FINISH: BA, 2B PE, N4 PE, CPP, No. 1

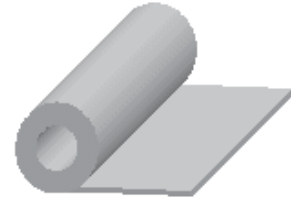

SIZE		304/L				316/L			3CR12	409L	253MA		321		2101	2205
		BA	2B PE	N4 PE	CPP/ N1	2B PE	N4 PE	CPP/ N1	1.4003	2B	2B	No.1	2B	No.1		
0.55mm	915		☆													
	1219		★	☆		★	☆						★			
0.7mm	915		☆													
	1219	★	★	☆		★	★						★			
0.9mm	915		☆													
	1219	★	★	★		★	★						☆			
1.2mm	915		★	★												
	1219	★	★	★		★	★						★	☆	☆	
	1500		★	★		★	★									
1.5mm	915		★	★												
	1219	★	★	★		★	★						★			
	1250								☆		★			☆	☆	
	1500		★	★		★	★						★			
2mm	915															
	1219		★	★		★	★						★			
	1250								★	★	★			☆	☆	
	1500		★	★		★	★		★	☆						
	2000		★			★										
2.5mm	1219		★	★		★										
	1500		★	★		★										
3mm	915															
	1219		★	★		★	★						★			
	1250								★		★			☆	☆	
	1500		★	★		★	★		★				★	☆	☆	
	2000		★			★			☆			★	☆	☆	★	
3.5mm	1500							★								
4mm	1219		★		☆	★										
	1500		★		☆	★						★		☆	☆	
	2000		★		☆	★								☆	☆	
5mm	1219		★		★	★		★								
	1250								★							
	1500		★		★	★		★	★		★		★	☆	☆	
	2000		★		★	★		★	★		★			☆	★	
6mm	1219		★		★	★		★								
	1250								★							
	1500		★		★	★		★	★				★	☆	☆	
	2000		★		★	★		★	★		★			☆	★	
8mm	1219				★			★								
	1500		★		★			★								
	2000		★		★			★			★					
10mm	1219				★			★								
	1500				★			★								
	2000				★			★					★			

SHEET

SPECIFICATIONS: ASTM A240/480
FINISH: 2B, 2B PE, N4 PE, BA PE, N8 PE

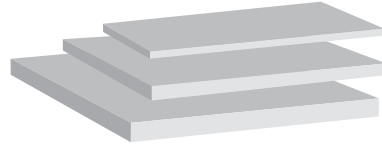

SIZE		304					316			253MA	3CR12	321	LDX 2101
		2B	2B PE	N4 PE	BA PE	N8 PE	2B	2B PE	N4 PE	2B	1.4003 2B	2B	2B
0.45mm	915 x 1830												
	1219 x 2438	☆		☆									
0.55mm	915 x 1819	☆	☆	☆									
	915 x 2438	☆	☆	☆									
	1219 x 2438	★	☆	★			★						
0.7 mm	915 x 1830	☆	☆	☆									
	915 x 2438	☆	☆	☆									
	1219 x 2438	★		★	★		★		★				
0.9mm	915 x 1830	☆	☆	★									
	915 x 2438	★	☆	☆									
	1219 x 2438	★	★	★	★		★	★	★				
	1219 x 3048		★	★									
	1500 x 3000			★									
	1524 x 2438			★									
1mm	1219 x 2438					★				★			
1.2mm	915 x 1830	☆	☆	★									
	915 x 2438	★	☆	★									
	1219 x 2438	★	★	★	★	★	★	★	★			★	
	1219 x 3048	☆	★	★									
	1219 x 1829	★		★			☆		☆				
	1219 x 3658	☆		★			☆		☆				
	1500 x 3000	★	★	★				★	★				
	1524 x 2438	☆		★			☆		☆				
1.5mm	915 x 1830	★	☆	☆									
	915 x 2438	★	☆	★									
	915 x 3658	★											
	1219 x 1830	☆	☆	☆				☆					
	1219 x 2438	★	★	★	★	★	★	★	★			★	☆
	1219 x 3048	★	★	★				★	★				
	1219 x 3658	☆		★			☆		☆				
	1250 x 2400												
	1250 x 2500									★	★		
	1500 x 3000	★	★	★			★	★	★				☆
1500 x 4000		★	★										

The latest Fibre Optic & CO₂ Laser Film coatings are utilised with our Stretcher Levelled Laser Flat material to ensure superior quality sheet and plate

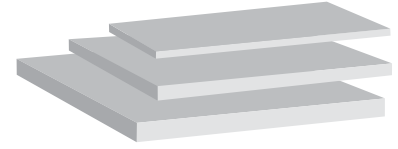
SHEET**SPECIFICATIONS:** ASTM A240/480**FINISH:** 2B, 2B PE, N4 PE, BA PE, N8 PE

SIZE		304				316				253MA	3CR12	321	LDX 2101
		2B	2B PE	N4 PE	BA PE	2B	2B PE	N4 PE	N8 PE	2B	1.4003 2B	2B	2B
2mm	915 x 1819	★	☆	☆		☆	☆	☆					
	915 x 2438	☆	☆	☆		☆	☆	☆					
	1219 x 1830	★	★				☆						
	1219 x 2438	★	★	★	★	★	★	★	★			★	☆
	1219 x 3048	★	★	★			★						
	1250 x 2400												
	1250 x 2500									★	★		
	1500 x 3000	☆	★	★		★	★	★			☆	☆	☆
	1500 x 4000		★	★									
	2.5mm	915 x 1830	☆	☆	☆								
915 x 2438		☆	☆	☆									
1219 x 2438		★	★	★	★	★	★	☆					
1219 x 3000		☆	★	☆									
1500 x 3000		☆	★	★			★						
1500 x 4000			★	★									
3mm	915 x 1830	★	☆	☆		☆	☆						
	915 x 2438	★	☆	☆		☆	☆						
	1219 x 1830		☆				☆						
	1219 x 2438	★	★	★		★	★	★	★			★	☆
	1219 x 3048	☆	★	☆		☆	★	★					
	1250 x 2500									★	★		
	1250 x 3000										★		
	1500 x 3000	★	★	★		☆	★	★			★	★	☆
	1500 x 4000	☆	★	★									

The latest Fibre Optic & CO₂ Laser Film coatings are utilised with our Stretcher Levelled Laser Flat material to ensure superior quality sheet and plate

PERFORATED SHEET

STANDARD SIZE: 2438 x 1219mm

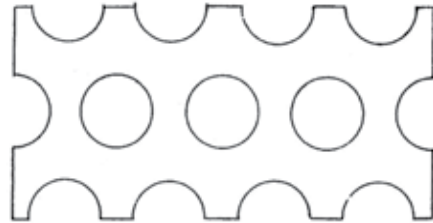

THICKNESS	HOLE DIA (A)	CENTRES (B)	OPEN AREA %	304	316
0.7mm	1.6	2.54	36	★	☆
0.9mm	2.06	3.10	41	★	☆
0.9mm	3.25	4.52	46	★	☆
0.9mm	4.76	6.35	51	★	☆
1.5mm	3.25	5.59	30	★	☆
1.5mm	3.97	5.59	46	★	☆
1.5mm	4.76	6.35	51	★	☆
1.5mm	6.35	9.55	40	★	☆
1.5mm	9.53	14.3	40	★	☆
1.5mm	12.7	17.3	49	★	☆

**Note: Different sheet sizes are available upon request **

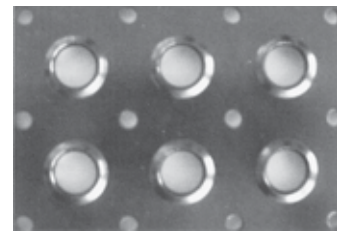

SAFETY TREAD SHEET

SIZE		RAISED HOLE DIA	DRAIN HOLD DIA	CENTRES	304	316
2.0mm	2438 x 1219mm	13.0mm	5.0mm	38mm	★	☆

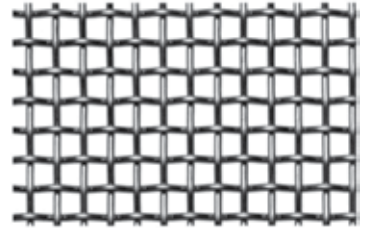
WELDED and WOVEN MESH**GRADE:** T304 (316 is optional on request)

WELDED MESH PANELS			WELDED MESH ROLLS		
SIZE	WIRE DIA	APERTURE	WIDTH	WIRE DIA	APERTURE
2400 x 1200mm	3.15mm	25.0mm	1220mm	0.8mm	6.25mm
2400 x 1200mm	3.15mm	40.0mm	1220mm	1.0mm	8.33mm
2400 x 1200mm	4.0mm	50.0mm	1220mm	1.2mm	12.5mm
			1220mm	1.6mm	12.5mm
			1220mm	1.6mm	25.0mm
			1220mm	2.0mm	25.0mm

WELDED MESH ROLLS		
WIDTH	WIRE DIA	APERTURE
1220mm	0.9mm	1.64mm
1220mm	1.6mm	11.2mm
1220mm	3.15mm	25.0mm

**Note: Minimum cut to length for welded and woven mesh rolls is one metre. Full size range of woven mesh is available upon request **

PLATE

SPECIFICATIONS: ASTM A240/480
FINISH: 2BPE, No. 1 HRAP

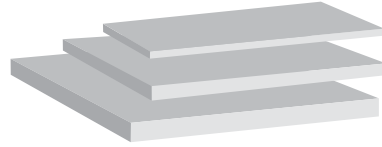

SIZE		TP304/L		TP316L		TP321	3CR12 1.4003	253MA	2205	LDX 2101
		2B PE	No.1	2B PE	No.1					
2mm	2000 x 4000	★		★						
3mm	1500 x 3000	☆		☆		☆	☆		☆	
	1219 x 6000	☆		☆			☆			
	1500 x 6000	★		★		★	★			★
	2000 x 3000	★								
4mm	2000 x 4000	★		★						
	2000 x 6000	★		★		★		★	★	
	1219 x 2438	★		★						
	1500 x 3000	★		★						
	1500 x 4000	★						★		
	1500 x 6000	★	☆	★				★		★
5mm	2000 x 4000	★								
	2000 x 6000	★	☆	★					☆	
	1219 x 2438	★	★	★	★					
	1250 x 2500						★			
	1500 x 3000	★	★	★	★	★	★	★		
	1500 x 4000	★								
	1500 x 6000	★	★	★	★	★	★		★	★
	2000 x 4000	★	★							
6mm	2000 x 6000	★	★	★	★	★	☆	★	★	
	2500 x 6000		☆		☆					
	1219 x 2438	★	★	★	★					
	1250 x 2500						★			
	1250 x 6000						★			
	1500 x 3000	★	★	★	★	★	★			
	1500 x 4000	★								
	1500 x 6000	★	★	★	★	★	★			★
	2000 x 4000	★								
	2000 x 6000	★	★	★	★	★	★	★	★	★
8mm	2500 x 6000		☆		☆					
	2500 x 7500						☆			
	1219 x 2438		★		★					
	1500 x 3000	★	★		★					
	1500 x 6000	★	★		★	★	★			
	2000 x 4000									
	2000 x 6000	★	★		★	★	★	★	★	★
	2500 x 6000		☆		★					
10mm	2500 x 7500		★		☆		☆			
	1219 x 2438		★		★					
	1500 x 3000		★		★	★	★			
	1500 x 6000		★		★	★	★			
	2000 x 6000		★		★	★	★	★	★	
	2500 x 6000		☆		☆					

PLATE

SPECIFICATIONS: ASTM A240/480

FINISH: CPP, No. 1 HRAP

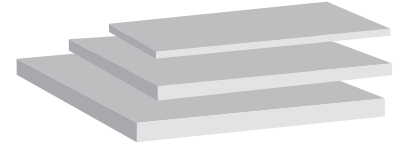

SIZE		TP 304/L	TP 316L	TP 321	3CR12 1.4003	253MA	2205
12mm	1219 x 2438	★	★				
	3000 x 1500	★	★	★	★		
	1500 x 4000	★	☆				
	1500 x 6000	★	★	★	★		
	2000 x 6000	★	★	★	★	★	★
	2500 x 6000	☆	☆				
	2500 x 7000	☆	☆				
	2500 x 7500	★	★		☆		
13mm	2000 x 6000	★	★				
16mm	1219 x 2438	★	★				
	1500 x 3000	★	★				
	1500 x 6000	☆	★		★	★	
	2000 x 6000	★	★	★	★	★	★
	2500 x 6000	☆	★				
	2500 x 7500	☆	★				
17mm	2000 x 6000	★	★				
19mm	2000 x 6000	★	★				
20mm	1219 x 2438	★	★				
	1500 x 3000	★	★				
	1500 x 6000	★	★		★		
	2000 x 6000	★	★	★	★	★	★
	2500 x 6000	☆	☆				
	2500 x 7500	★	☆				
22mm	2000 x 6000	★	★				
25mm	1219 x 2438	★	★				
	1500 x 3000	☆	☆				
	1500 x 6000	★	★	☆	★		
	2000 x 6000	★	★	★	★	★	★
	2500 x 6000	☆	★				
32mm	1500 x 6000	☆	★				
	2000 x 6000	★	★	★			☆
	2500 x 6000	☆	★				
40mm	1500 x 6000	☆	★				
	2000 x 6000	★	★	★	★		☆
	2500 x 6000	★	☆				
50mm	1500 x 6000	☆	☆				
	2000 x 6000	★	★	★	★		☆
65mm	2000 x 4000	★	★				
80mm	2000 x 4000	★	★				

FLOOR PLATE / COIL

SPECIFICATIONS: ASTM A240/480
FINISH: PRESSED FLOOR PLATE, HRAP CHEQUER PLATE

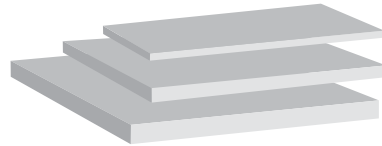

SIZE		TP 304	TP 316
PRESSED FLOOR PLATE			
2mm	1219 x 2438	★	☆
3mm	1219 x 2438	★	☆
	1219 x 3048	☆	☆
4.5mm	1219 x 2438	★	☆
	1500 x 3000	★	☆
6mm	1219 x 2438	☆	☆
HRAP CHEQUER PLATE			
3.5mm	1219 x 2438	★	☆
4.5mm	1219 x 2438	★	☆
	1524 x 3000	★	☆
6mm	1219 x 2438	★	☆
	1219 x 6000	★	☆
	1524 x 3000	★	☆
HRAP CHEQUER PLATE COIL			
3.5mm	1219	★	☆
4.5mm	1219	★	☆
	1524	★	☆
6mm	1219	★	
	1524	★	

PLATE PROCESSING FACILITIES

Midway Metals has state of the art Plasma Cutting facilities, capable of cutting Stainless Steel from 2mm to 80mm in thickness. All machines are linked to the latest Fastcam Computer Software, with full Nesting facilities including standard developments of cones, square to rounds, branches and Lobster Back bends.

The advantages of using Midway Metals processing include:

- Australia's largest capacity for plasma cut plate processing with facilities in Brisbane, Sydney, Melbourne and Perth.
- Versatility of cutting widths and lengths. We can handle large dimensional plates ensuring large profiles are supplied in one piece.
- DXF files can be supplied by Computer Disc or by our email facility. DXF files can be emailed, saving time and ensuring quicker response to shut down/ breakdown situations.
- Send all DXF files to plasma@midwaymetals.com.au
- Tolerances and finishes have been improved due to advancements in technology. Increased cutting capacity and metre rates has lead to more efficient costings for the client.
- We stock a wide variety of plate sizes and grades:
 - 304/304L
 - 316/316L
 - 321
 - 2101
 - 2205
 - 253MA
 - 3CR12 (1.4003)

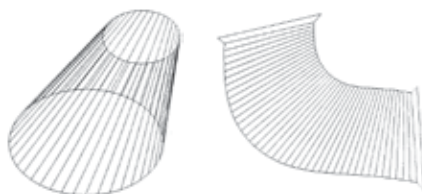
*LOBSTER**RECTIRCLE**P BRANCH**CONE*

STANDARD PLASMA TOLERANCES AS3902/ISO9002

Minimum Hole Size

A) Cut quality suitable.
To machine to finished size.
Not suitable for cut sizes.

THICKNESS	MIN. HOLE SIZE
<10mm	30mm DIA
>10mm <19mm	50mm DIA
>19mm <40mm	70mm DIA
>40mm <100mm	200mm DIA

B) Standard Cut Quality.

THICKNESS	MIN. HOLE SIZE
<10mm	60mm DIA
>10mm <19mm	80mm DIA
>19mm < 40mm	140mm DIA
>40mm < 100mm	200mm DIA

Minimum Width 25mm or 2 x thickness whichever is greater

Minimum Length 2 x thickness or 100mm which ever is greater

PLASMA CUTTING SHEETS & PLATES

Standard tolerances Acc. ASTM A480.

Note the Flatness levels quoted by this standard refer to the feed material and not to the product of the plasma cutting operation.

Plasma Cutting - Standard Production Tolerances - Cut Size

THICKNESS	OUTSIDE DIMENSION		INSIDE DIMENSION	
	<1500mm	>1500mm	<1500mm	>1500mm
<50mm	-1	-1	-5	-6
	+5	+9	+1	+1
>50mm	-1	-1	-6	-8
	+6	+8	+1	+1

ROUND BAR - IMPROVED MACHINING

SPECIFICATIONS:	ASTM A276 / A484
LENGTHS:	4 METRE FIXED & RANDOMS
FINISH:	COLD DRAWN & POLISHED PEELED & REELED CENTRELESS/PRECISION GROUND
TOLERANCE:	H8 / H9 / H10 / H11 / K12



SIZE	303	304	316	431	2205	253MA	APPROX. WEIGHT
mm							kg/metre
3.18		★	★				0.062
3.96		★	★				0.1
4.76		★	★				0.14
5		★	★				0.155
6	☆	★	★			★	0.23
6.35	☆	★	★				0.25
7.94		★	★				0.39
8	★	★	★			★	0.4
9.53	☆	★	★	☆			0.56
10	★	★	★	☆		★	0.62
11.11		★	★				0.76
12	☆	★	★	☆	★	★	0.89
12.7	★	★	★				0.99
14.28		★	★				1.26
15		★					1.39
15.88	★	★	★	★			1.552
16		★	★			★	1.58
19.05	★	★	★	★	☆		2.235
20	☆	★	★	★	★	★	2.47
22.23	★	★	★	★			3.042
24		★	★				3.551
25	☆	★	★	☆		★	3.853
25.4	☆	★	★	★	★		3.973
28.58		★	★	★			5.03
30	★	★	★				5.55
31.75	★	★	★	★	★		6.21
34.93		★	★				7.512
35		★	★			★	7.553
36		☆	★				8
38.1		★	★	★	★		8.94
40		★	★			★	9.87
41.28		☆	★				10.5

ROUND BAR - IMPROVED MACHINING

SPECIFICATIONS:	ASTM A276 / A484
LENGTHS:	4 METRE FIXED & RANDOMS
FINISH:	COLD DRAWN & POLISHED PEELED & REELED CENTRELESS/PRECISION GROUND
TOLERANCE:	H8 / H9 / H10 / H11 / K12



SIZE	303	304	316	431	2205	253MA	APPROX. WEIGHT
mm							kg/metre
44.45		★	★	★	★		12.17
45		★					12.49
50		★	★			★	15.413
50.8		★	★	★	★		15.9
57.15		★	★	★	★		20.12
60		★	★				22.2
63.5		★	★	★	★		24.84
69.85		★	★	★			30.05
70						★	30.2
76.2		★	★	★	☆		35.76
80				★		★	39.46
82.55		★	★	★	☆		41.98
88.9		★	★	★			48.68
90						★	49.9
95.25			☆				55.88
101.6		★	★	★			63.59
108		★					73.2
110						★	74.6
114.3		★	★				81.9
120			★				89.2
127		★	★			☆	100.9
139.7			★				122.5
152.4		★	★			★	144.9
165.1			★				169.9
177.8			★				196.9
203.2		☆	★				256.8
228.6			☆				324.7
254			★				403
279.4			★				487.6
304.8			★				575.9

TECHNICAL DATA

Stainless steel bar is usually supplied to comply with ASTM A276 (or ASTM A582 for free-machining grades). Both specifications refer to ASTM A484M for dimensional tolerances, except as noted below for round bar. Available tolerances will vary dependent upon bar section size, condition and finish.

ROUND BAR

Cold-finished round bar is usually supplied to ASTM A276/A484 OR A582/A484M

FINISH	DIAMETER TOLERANCE
DRAWN	H9
PEELED & REELED	H9 / H10
SMOOTH TURNED	H11 / K12
GROUND	H8 OR H9

NOMINAL BAR SIZE (mm)	TOLERANCE NUMBER								
	6	7	8	9	10	11	12	13	14
0 to 3	6	10	14	25	40	60	100	140	250
3 to 6	8	12	18	30	48	75	120	180	300
6 to 10	9	15	22	36	58	90	150	220	360
10 to 18	11	18	27	43	70	110	180	270	430
18 to 30	13	21	33	52	84	130	210	330	520
30 to 50	16	25	39	62	100	160	250	390	620
50 to 80	19	30	46	74	120	190	300	460	740
80 to 120	22	35	54	87	140	220	350	540	870
120 to 180	25	40	63	100	160	250	400	630	1000
180 to 250	29	46	72	115	185	290	460	720	1150
250 to 315	32	52	81	130	210	320	520	810	1300
315 to 400	36	57	89	140	230	360	570	890	1400
400 to 500	40	63	97	155	250	400	630	970	1550

Tolerance values given in microns = 0.001mm

H = all minus

J = equal

K = all plus

FLAT BAR

SPECIFICATIONS:	ASTM A276/A484M
LENGTHS:	4 METRE FIXED & RANDOMS
FINISH:	SLIT ROLLED EDGE (SRE) HOT ROLLED ANNEALED & PICKLED (HRAP)



SIZE mm	304		316		APPROX. WEIGHT kg/metre
	SRE	HRAP	SRE	HRAP	
3 x 12	★	☆	★	☆	0.317
3 x 20	★	☆	★	☆	0.48
3 x 25	★	★	★	☆	0.63
3 x 30	★	★	★	☆	0.79
3 x 40	★	★	★	☆	0.948
3 x 50	★	★	★	☆	1.3
3 x 65	★		★		1.53
3 x 75	★		★	☆	1.77
3 x 100	★		★		2.50
5 x 20	★	☆	★	☆	0.79
5 x 25	★	★	★	★	0.987
5 x 30	★	★	★	★	1.19
5 x 40	★	★	★	★	1.58
5 x 50	★	★	★	★	1.97
5 x 65	★	☆	★	☆	2.56
5 x 75	★	☆	★	☆	2.96
5 x 100	★		★		3.95
6 x 12		☆		★	0.648
6 x 20	★	★	★	☆	0.97
6 x 25	★	★	★	★	1.3
6 x 30	★	★	★	★	1.62
6 x 40	★	★	★	★	1.93
6 x 50	★	★	★	★	2.59
6 x 65	★	★	★	★	3.25
6 x 75	★	★	★	★	3.89
6 x 90	☆		☆		4.52
6 x 100	★	★	★	★	5.18
6 x 150	★	☆	★	☆	7.38
8 x 25	★				1.63
8 x 30	★				1.97
8 x 40	★		★		2.63
8 x 50	★	★	★	☆	3.28
8 x 65	★	★	★	☆	4.26
8 x 75	★	★	★	☆	4.92
8 x 100	★	★	★	☆	6.56

FLAT BAR

SPECIFICATIONS:	ASTM A276/A484M
LENGTHS:	4 METRE FIXED & RANDOMS
FINISH:	SLIT ROLLED EDGE (SRE) HOT ROLLED ANNEALED & PICKLED (HRAP)



SIZE mm	304		316		APPROX. WEIGHT kg/metre
	SRE	HRAP	SRE	HRAP	
10 x 20		★		★	1.58
10 x 25		★		★	1.97
10 x 30	☆	★	☆	★	2.43
10 x 40	☆	★	☆	★	3.16
10 x 50	☆	★	☆	★	3.96
10 x 65	☆	★	☆	★	5.13
10 x 75	☆	★	☆	★	5.93
10 x 100	☆	★	☆	★	7.9
10 x 125	☆	☆	☆	☆	10.16
10 x 150	☆	★	☆	★	11.83
12 x 25		★		★	2.59
12 x 30	☆	☆	☆	☆	3.25
12 x 40	☆	★	☆	★	3.89
12 x 50	☆	★	☆	★	5.18
12 x 65	☆	★	☆	★	6.48
12 x 75	☆	★	☆	★	7.77
12 x 100	☆	★	☆	★	10.36
12 x 150		★		★	15.50
16 x 40		★		☆	5.05
16 x 50		★		★	6.48
16 x 65		★		☆	8.21
16 x 75		★		★	9.35
16 x 100		★		☆	13.10
20 x 40		★		★	6.56
20 x 50		★		★	7.9
20 x 65		☆		☆	10.2
20 x 75		★		★	11.9
20 x 100		★		★	15.8
25 x 50		★		★	10.36
25 x 75		★		☆	15.48
25 x 100		★		☆	20.69

ANGLE BAR

SPECIFICATIONS:	ASTM A276/A484M
LENGTHS:	6 METRE FIXED & RANDOMS
FINISH:	HOT ROLLED ANNEALED & PICKLED



SIZE	304	316	APPROX. WEIGHT
mm			kg/metre
3 X 20 X 20	★	★	0.9
3 X 25 X 25	★	★	1.21
3 X 30 X 30	★	★	1.53
3 X 40 X 40	★	★	1.86
3 X 50 X 50	★	★	2.5
4 X 30 X 30	☆	☆	1.95
4 X 40 X 40	☆	☆	2.6
5 X 25 X 25	★	★	1.77
5 X 30 X 30	★	★	2.25
5 X 40 X 40	★	★	2.98
5 X 50 X 50	★	★	3.79
6 X 25 X 25	★	★	2.26
6 X 30 X 30	★	★	2.92
6 X 40 X 40	★	★	3.56
6 X 50 X 50	★	★	4.95
6 X 65 X 65	★	★	6.16
6 x 50 x 75	☆	★	5.93
6 X 75 X 75	★	★	7.46
6 x 75 x 100	☆	★	8.35
6 X 100 X 100	★	★	10.05
8 x 75 x 75	★	☆	9.94
10 X 50 X 50	★	★	7.06
10 X 65 X 65	★	★	9.48
10 X 75 X 75	★	★	11.1
10 X 100 X 100	★	★	15
10 X 125 X 125	★	☆	20.1
10 X 150 X 150	☆	☆	23.7
12 x 100 x 100	☆	★	19.6

HEXAGON BAR

SPECIFICATIONS: ASTM A276/A582/A484M

LENGTHS: RANDOMS

FINISH: COLD DRAWN (CD)
HOT ROLLED (HR) &
ANNEALED (HRAP)



SIZE	304	316	AVG. WEIGHT
mm			kg/metre
6.35	☆	☆	0.28
7.92	☆	☆	0.44
8	☆	☆	0.45
9.53	☆	☆	0.65
11.3	☆	★	0.91
13.34	☆	★	1.25
15.24	☆	★	1.63
17	☆	☆	2.02
18.03	☆	★	2.27
19.05	☆	★	2.53
20	★	☆	3
20.83	☆	★	3.02
22.23	☆	★	3.36
23.37	☆	★	3.79
25.65	☆	★	4.56
28.58	☆	★	5.65
30.48	☆	★	6.42
31.75	☆	☆	6.86
33.05	☆	☆	7.54
37.59	☆	★	9.86
42.42	☆	☆	12.5
47.63	☆	☆	15.73
50.8	☆	☆	17.87
57.15	☆	☆	22.57
63.5	☆	☆	27.83

HOLLOW BAR

GRADE:	316 (FREE MACHINING)
SPECIFICATIONS:	ASTM A511
LENGTHS:	2 TO 6 METRES
TOLERANCE:	OUTSIDE DIAMETER +2 / -0% INSIDE DIAMETER +0 / -2%

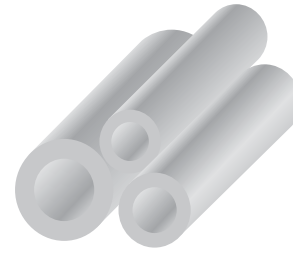

SIZE		DIMENSIONS AFTER ROUGH MACHINING				AVERAGE WEIGHT	316
O.D.	I.D.	CHUCKED TRUE TO O.D.		CHUCKED TRUE TO I.D.		kg/metre	
mm	mm	MAX O.D. mm	MIN I.D. mm	MAX O.D. mm	MIN I.D. mm		
32	20	31	22	30	21	4.23	☆
	16	31	18	30	17	5.11	★
36	25	35	27	34	26	4.58	★
	20	35	22	34	21	5.96	★
	16	35	18.5	33.5	17	6.84	★
40	28	39	30	38	29	5.53	★
	25	39	27	38	26	6.51	★
	20	39	22.5	37.5	21	7.89	★
45	32	44	34	43	33	6.75	☆
	28	44	30.5	42.5	29	8.23	★
	20	44	22.5	42.5	21	10.6	★
50	36	49	38	48	37	8.08	☆
	32	49	34.5	47.5	33	9.75	★
	25	49	27.5	47.5	26	12.2	★
56	40	55	42	54	41	10.3	★
	36	55	38.5	53.5	37	12.1	★
	28	55	30.5	53.5	29	15.3	★
63	50	62	52	61	51	10	★
	40	62	42.5	60.5	41	15.6	★
	36	62	38.5	60.5	37	17.5	☆
	32	62	34.5	60.5	33	19.1	★
71	56	69.5	58	69	57	13	★
	45	69.5	47.5	68.5	46	19.8	★
	40	69.5	42.5	68.5	41	22.4	★
	36	69.5	38.5	68.5	37	24.3	★
75	40	73.5	42.5	72	41	26.2	★
80	63	78.5	65.5	77.5	64	16.5	★
	50	78.5	52.5	77	51	25.5	★
	45	78.5	47.5	77	46	28.5	☆
	40	78.5	43	77	41	31.1	★
85	45	83.5	48	82	46	33.7	★
90	71	88.5	73.5	87.5	72.5	20.8	★
	63	88.5	65.5	87	64	27.4	★
	56	88.5	58.5	87	57	32.5	☆
	50	88.5	53	87	51	36.4	★
95	50	93.5	52	91	51	42.3	☆
100	80	98.5	82.5	97	81.5	24.6	★
	71	98.5	73.5	97	72.5	32.9	★
	63	98.5	65.5	96.5	64	39.5	★
	56	98.5	59	96.5	57	44.6	★
106	80	104	82.5	103	81.5	32.5	★
	71	104	74	102.5	72.5	40.8	★
	63	104	66	102.5	64	47.4	★
	56	104	59	102.5	57	52.5	★

HOLLOW BAR

GRADE:	316 (FREE MACHINING)
SPECIFICATIONS:	ASTM A511
LENGTHS:	2 TO 6 METRES
TOLERANCE:	OUTSIDE DIAMETER +2 / -0% INSIDE DIAMETER +0 / -2%

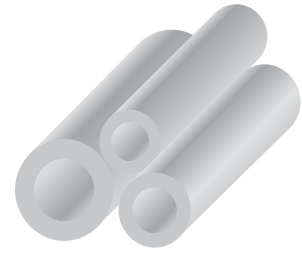

SIZE		DIMENSIONS AFTER ROUGH MACHINING				AVERAGE WEIGHT	316
O.D.	I.D.	CHUCKED TRUE TO O.D.		CHUCKED TRUE TO I.D.		kg/metre	
mm	mm	MAX O.D. mm	MIN I.D. mm	MAX O.D. mm	MIN I.D. mm		
112	v	110	93	109	91.5	30.4	☆
	80	110	83	108.5	81.5	40.8	★
	71	110	74	108.5	72.5	49.2	★
	63	110	66	108	64	55.8	★
118	90	116	93	114.5	91.5	39.2	★
	80	116	83	114.5	81.5	49.7	★
	71	116	74	114	72.5	57.9	☆
	63	116	66	114	64	64.6	★
125	100	123	103	121.5	101.5	38.4	★
	90	123	93	121.5	91.5	50.1	★
	80	123	83	121	81.5	60.5	★
	71	123	74.5	121	72.5	68.9	★
132	106	130	109	128.5	108	42.3	★
	90	130	93.5	128	91.5	61.6	★
	80	130	83.5	128	81.5	72	★
	71	130	74.5	127.5	72.5	80.3	★
140	112	137.5	115	136.5	114	48.2	★
	100	137.5	103.5	136	101.5	63.8	★
	90	137.5	93.5	136	91.5	75.4	☆
	80	137.5	83.5	135.5	81.5	85.9	★
150	125	147.5	128.5	146	127	47.8	★
	106	147.5	109.5	146	108	74.7	★
	95	147.5	98.5	145.5	96.5	88.3	☆
	80	147.5	84	145	81.5	104.4	★
160	132	157.5	135.5	156	134	56.6	★
	122	157.5	125.5	156	124	72.1	☆
	112	157.5	115.5	155.5	114	86.5	★
170	140	167	143.5	166	142.5	64.3	★
	130	167	134	165.5	132	81	☆
	118	167	122	165.5	120	99.1	★
180	150	177	154	175.5	152.5	68.9	☆
	140	177	144	175.5	142.5	86.6	★
	125	177	129	175	127	111	★
190	160	187	164	185.5	162.5	73.5	★
	150	187	154	185.5	152.5	92.4	☆
	132	187	136.5	185	134	123.6	★
200	160	197	164	195	162.5	98.4	☆
	150	197	154.5	195	152.5	117.3	☆
	140	197	144.5	194.5	142.5	135.2	★
212	170	208.5	174.5	207	173	109.7	★
	130	208.5	135	206	132	183.3	★
224	180	220.5	184.5	218.5	183	121.6	☆
	140	220.5	145	217.5	142.5	200.2	☆
236	190	232	195	230.5	193	134.2	★
	150	232	155.5	229.5	152.5	217.6	★
250	200	246	205	244	203	153.7	★

SQUARE BAR

SPECIFICATIONS:	ASTM A276/A582/A484M
LENGTHS:	RANDOMS
FINISH:	COLD DRAWN (CD), HOT ROLLED ANNEALED & PICKLED (HRAP)



SIZE	304	316	AVG. WEIGHT
mm			kg/metre
4	☆	☆	0.13
6	☆	★	0.33
6.35	☆	☆	0.34
8	★	★	0.53
9.52	☆	☆	0.75
10	★	★	0.8
12	★	★	1.27
12.7	☆	☆	1.32
15.88	☆	☆	2.03
16	★	★	2.05
19.05	★	☆	2.98
20	★	★	3.21
25	★	★	5.18
25.4	☆	☆	5.29
32	★	★	8.21
38.1	★	☆	11.9
40	★	★	12.83
45	☆	☆	16.24
50	★	★	20.05
50.8	☆	☆	21.2
63.5	☆	★	31.65

TECHNICAL DATA

Stainless steel bar is usually supplied to comply with ASTM A276 (or ASTM A582 for free-machining grades). Both specification refer to ASTM A484M for dimensional tolerances. Available tolerances will vary dependent upon bar section size, condition and finish.

FLAT BAR

Hot-finished (HRAP to ASTM A276 / A484M)

These tolerances are for hot finished flat bars, rolled as bars, in HRAP condition.

Note that different tolerances apply for flat bar cut from coil, sheet or plate.

WIDTH mm	THICKNESS TOLERANCE FOR THICKNESS mm			WIDTH TOLERANCE mm (SRE)
	3.2 to 13	13 to 25	25 to 50	
UP to 25	+/- 0.20	+/- 0.25	–	+/- 0.40
25 to 50	+/- 0.30	+/- 0.40	+/- 0.80	+/- 0.80
50 to 100	+/- 0.40	+/- 0.50	+/- 0.80	+ 1.6 to - 0.80
100 to 150	+/- 0.40	+/- 0.50	+/- 0.80	+ 2.40 to -1.60

SQUARE & HEXAGONAL BAR

Cold-finished to ASTM A276 / A582 / A484M)

SPECIFIED SIZE mm	SIZE TOLERANCE mm
3.00 to 8.00	+Nil, - 0.05
8.00 to 13.00	+Nil, - 0.08
13.00 to 25.00	+Nil, - 0.10
25.00 to 50.00	+Nil, - 0.15
50.00 to 75.00	+Nil, - 0.20
over 75.00	+Nil, - 0.25

ANGLE BAR

Hot-finished to ASTM A276 / A484M)

LENGTH OF LEG	LEG TOLERANCE
up to 150mm	+/- 3.0mm
over 150mm	+/- 5.0 - 3.0mm

CHANNEL

SPECIFICATIONS:	ASTM A276/A484M
LENGTHS:	6 METRES FIXED
FINISH:	HOT ROLLED, ANNEALED & PICKLED (HRAP)
GRADE:	304 / 316

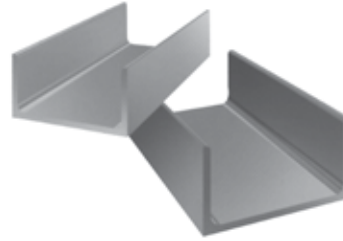

SIZE mm	304	316
T x H x B		
3 x 40 x 20	☆	☆
3 x 50 x 25	☆	☆
4 x 60 x 30	☆	☆
4 x 35 x 70	☆	☆
4 x 80 x 40	☆	☆
4 x 90 x 45	☆	☆
4 x 100 x 50	☆	☆
5 x 60 x 30	☆	☆
5 x 70 x 35	☆	☆
5 x 80 x 40	☆	★
5 x 90 x 45	☆	☆
5 x 100 x 50	☆	☆
5 x 120 x 60	☆	☆
5 x 130 x 65	☆	☆
6 x 60 x 30	☆	☆
6 x 70 x 35	☆	☆
6 x 80 x 40	☆	☆
6 x 90 x 45	☆	☆
6 x 100 x 50	★	★
6 x 120 x 60	☆	☆
6 x 130 x 65	☆	☆
6 x 140 x 70	☆	☆
6 x 150 x 75	★	★
6 x 160 x 80	☆	☆
6 x 180 x 90	☆	☆
6 x 200 x 100	☆	☆
9 x 150 x 75		★
10 x 200 x 100		★

TECHNICAL DATA

CHANNEL TOLERANCES

UNIT WEIGHT KG/MTR

SIZE mm	THICKNESS T mm							
H x B	3	4	5	6	7	8	9	10
40 x 20	1.79							
50 x 25	2.27							
60 x 30		3.56	4.37	5.12				
70 x 35		4.21	5.17	6.08				
80 x 40		4.48	5.96	7.03				
90 x 45		5.55	6.83	8.05				
100 x 50		6.18	7.62	8.98	10.3	11.7	13.0	14.2
120 x 60			9.20	10.9	12.6	14.2		
130 x 65			10.1	11.9	13.8	15.5	17.3	19.1
140 x 70				12.9	14.9	16.8	19.8	20.7
150 x 75				13.8	16.0	18.1	20.2	22.2
160 x 80				14.8	17.1	19.3	21.6	23.8
180 x 90				16.7	19.4	22.0	24.5	27.0
200 x 100				18.6	21.6	24.5	27.4	30.2

SIZE TOLERANCES

SIZE mm				THICKNESS T mm							
H	Tolerance	B	Tolerance	3	4	5	6	7	8	9	10
40	±1.5	20	±1.5	±0.4							
50	±1.5	25	±1.5	±0.4							
60	±2.0	30	±1.5		±0.4	±0.4	±0.4				
70	±2.0	35	±1.5		±0.4	±0.4	±0.4				
80	±2.0	40	±1.5		±0.4	±0.6	±0.4				
90	±2.0	45	±1.5		±0.4	±0.4	±0.4				
100	±2.0	50	±2.0		±0.6	±0.6	±0.6	±0.4	±0.4	±0.4	±0.6
120	±3.0	60	±3.0			±0.4	±0.4	±0.4	±0.4		
130	±3.0	65	±3.0			±0.4	±0.6	±0.4	±0.4	±0.4	±0.6
140	±3.0	70	±3.0				±0.6	±0.6	±0.6	±0.6	±0.6
150	±3.0	75	±3.0				*±0.6	±0.6	±0.6	*±0.6	±0.6
160	±3.0	80	±3.0				±0.6	±0.6	±0.6	±0.6	±0.6
180	±3.0	90	±3.0				±0.6	±0.6	±0.6	±0.6	±0.6
200	±4.0	100	±3.0				±0.6	±0.6	±0.6	±0.6	±0.6

SEAMLESS & WELDED PIPE

SPECIFICATIONS:	ASTM A312M-08	
LENGTHS:	6.1 METRE/RANDOMS	
FINISH:	WELDED SEAMLESS	ANNEALED & PICKLED COLD FINISH/HOT FINISH

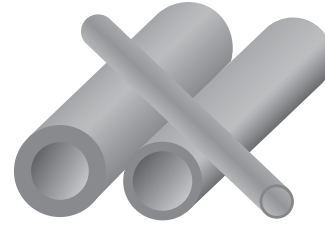

NB PIPE SIZE		SIZE		WELDED			SEAMLESS			APPROX. WGT
Inch	mm	O.D.	WT	304/L	316/L	2205	304/L	316/L	2205	kg/metre
SCHEDULE 10 / 10s										
1/8	6	10.287	1.244			☆	☆	☆		0.2772
1/4	8	13.716	1.651	★	★	☆	☆	★	☆	0.4905
3/8	10	17.145	1.651	★	★	☆	☆	☆	☆	0.6301
1/2	15	21.336	2.108	★	★	☆	★	★	☆	0.9984
3/4	20	26.67	2.108	★	★	☆	★	★	☆	1.275
1	25	33.401	2.768	★	★	☆	★	★	☆	2.089
1 1/4	32	42.164	2.768	★	★	☆	☆	★	☆	2.687
1 1/2	40	48.26	2.768	★	★	☆	★	★	☆	3.102
2	50	60.325	2.768	★	★	☆	★	★	☆	3.925
2 1/2	65	73.025	3.048	★	★	☆	★	★	☆	5.254
3	80	88.9	3.048	★	★	☆	★	★	☆	6.45
3 1/2	90	101.6	3.048	★	★	☆	☆	☆	☆	7.399
4	100	114.3	3.048	★	★	☆	☆	★	☆	8.352
5	125	141.3	3.403	★	★	☆	☆	☆	☆	11.56
6	150	168.275	3.403	★	★	☆	☆	★	☆	13.82
8	200	219.075	3.759	★	★	☆			☆	19.93
10	250	273.05	4.191	★	★	☆				27.82
12	300	323.85	4.572	★	★	☆				35.95
14	350	355.6	4.78	★	★	☆				42.1
16	400	406.4	4.78	★	★	☆				48.2
18	450	457.2	4.78	★	★					54.3
20	500	508	5.53	★	★					69.8
24	600	609.6	6.35	★	★					96.2
SCHEDULE 40s / STD WALL										
1/8	6	10.287	1.727					★		0.3641
1/4	8	13.716	2.235	★	★		★	★		0.6321
3/8	10	17.145	2.311	★	★	☆	★	★		0.8445
1/2	15	21.336	2.768	★	★	☆	★	★	★	1.266
3/4	20	26.67	2.87	★	★	☆	★	★		1.682
1	25	33.401	3.378	★	★	☆	★	★	☆	2.498
1 1/4	32	42.164	3.556	★	★	☆	★	★	☆	3.382
1 1/2	40	48.26	3.683	★	★	☆	★	★	☆	4.044
2	50	60.325	3.911	★	★	☆	★	★	☆	5.435
2 1/2	65	73.025	5.156	★	★	☆	☆	★	☆	8.619
3	80	88.9	5.486	★	★	☆	★	★	☆	11.27
3 1/2	90	101.6	5.74	★	★	☆	★	★	☆	13.55
4	100	114.3	6.019	★	★	☆	★	★	☆	16.05
5	125	141.3	6.553	★	★	☆	☆	★	☆	21.75
6	150	168.275	7.112	★	★	☆	★	★	☆	28.22
8	200	219.075	8.178	★	★	☆	☆	★	☆	42.48
10	250	273.05	9.271	★	★	☆				60.23
12	300	323.85	9.53	★	★	☆				73.88
14	350	355.6	9.53	☆	★	☆				81.2
16	400	406.4	9.53	☆	★					93.2
18	450	457.2	9.53	☆	★					105.1
20	500	508	9.53	☆	★					117.0
24	600	609.6	9.53	☆	★					140.8

SEAMLESS & WELDED PIPE

SPECIFICATIONS:	ASTM A312M-08	
LENGTHS:	6.1 METRE/RANDOMS	
FINISH:	WELDED SEAMLESS	ANNEALED & PICKLED COLD FINISH/HOT FINISH

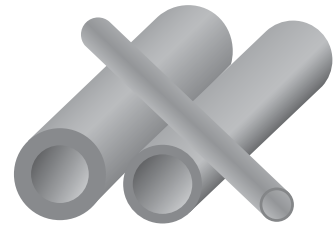

NB PIPE SIZE		SIZE		WELDED			SEAMLESS			APPROX. WGT
Inch	mm	O.D.	WT	304/L	316/L	2205	304/L	316/L	2205	kg/metre
SCHEDULE 80s / XS										
1/8	6	10.287	2.413					★		0.4679
1/4	8	13.716	3.023					★		0.7962
3/8	10	17.145	3.2					★		1.099
1/2	15	21.336	3.734				☆	★		1.618
3/4	20	26.67	3.911				☆	★	☆	2.193
1	25	33.401	4.546				☆	★	☆	3.231
1 1/4	32	42.164	4.851				★	★	☆	4.459
1 1/2	40	48.26	5.08				★	★	☆	5.402
2	50	60.325	5.537				★	★	☆	7.472
2 1/2	65	73.025	7.01				★	★	☆	11.39
3	80	88.9	7.62				★	★	☆	15.25
3 1/2	90	101.6	8.077				☆	★	☆	18.6
4	100	114.3	8.559				★	★	☆	22.29
5	125	141.3	9.525				☆	★	☆	30.92
6	150	168.275	10.97				★	★	☆	42.51
8	200	219.075	12.7				☆	★	☆	64.56
10	250	273.05	12.7					★		81.5
12	300	326.85	12.7							97.4
14	350	355.6	12.7							107.3
16	400	406.4	12.7							123.2
18	450	457.2	12.7							139.1
20	500	508	12.7							155.0
24	600	609.6	12.7							186.8
SCHEDULE 160										
1/2	15	21.336	4.75					★		1.94
3/4	20	26.67	5.537					★		2.882
1	25	33.401	6.35					★		4.231
1 1/4	32	42.164	6.35					☆		5.602
1 1/2	40	48.26	7.137					★		7.23
2	50	60.325	8.712					★		11.07
2 1/2	65	73.025	9.525					☆		14.89
3	80	88.9	11.12					☆		21.3
4	100	114.3	13.48					☆		33.49
5	125	141.3	15.87					☆		49.04
6	150	168.275	18.23					☆		67.4
8	200	219.075	23.01					☆		111.1
10	250	273.05	28.57							172
12	300	326.85	33.32							238.5
14	350	355.6	35.71							281.3
16	400	406.4	40.46							364.7
18	450	457.2	45.23							459
20	500	508	50.01							563.9
24	600	609.6	59.51							806.3

NOMINAL BURSTING PRESSURE

TECHNICAL DATA FOR 304, 316 & 321 SEAMLESS PIPE

NOMINAL BORE SIZE	SCHEDULE 10s										SCHEDULE 40s										SCHEDULE 80s															
	50	100	150	200	250	300	350	400	50	100	150	200	250	300	350	400	50	100	150	200	250	300	350	400	50	100	150	200	250	300	350	400				
mm	TEMPERATURE °C																																			
6	30.1	26.8	23.4	21.7	20.2	19.2	18.5	17.9	42	37.3	32.6	30.3	28.2	26.7	25.9	25	58.6	52	45.5	42.2	39.3	37.3	36	34.8												
8	30.1	26.8	23.4	21.7	20.2	19.2	18.5	17.9	40.9	36.3	31.8	29.5	27.5	26	25.2	24.3	55.2	49	42.8	39.7	37	35.1	33.9	32.8												
10	24.1	21.4	18.7	17.4	16.2	15.4	14.9	14.4	33.8	30	26.2	24.3	22.7	21.5	20.8	20.1	46.8	41.6	36.4	33.7	31.4	29.8	28.8	27.8												
15	24.8	22	19.2	17.9	16.6	15.8	15.3	14.7	32.5	28.9	25.3	23.4	21.8	20.7	20	19.3	43.8	38.9	34	31.6	29.4	27.9	27	26												
20	19.8	17.6	15.4	14.2	13.3	12.6	12.2	11.8	26.9	23.9	20.9	19.4	18.1	17.1	16.6	16	36.6	32.5	28.4	26.4	24.6	23.3	22.6	21.8												
25	20.8	18.4	16.1	14.9	13.9	13.2	12.8	12.3	25.3	22.5	19.7	18.2	17	16.1	15.6	15.1	34.1	30.3	26.5	24.6	22.9	21.7	21	20.3												
32	16.4	14.6	12.8	11.8	11	10.5	10.1	9.8	21.1	18.7	16.4	15.2	14.2	13.4	13	12.5	28.8	25.5	22.3	20.7	19.3	18.3	17.7	17.1												
40	14.4	12.7	11.1	10.3	9.6	9.1	8.8	8.5	19.1	16.9	14.8	13.7	12.8	12.1	11.7	11.3	26.3	23.4	20.4	19	17.7	16.7	16.2	15.6												
50	11.5	10.2	8.9	8.3	7.7	7.3	7.1	6.8	16.2	14.4	12.6	11.7	10.9	10.3	10	9.6	23	20.4	17.8	16.6	15.4	14.6	14.1	13.7												
65	10.5	9.3	8.1	7.5	7	6.7	6.4	6.2	17.7	15.7	13.7	12.7	11.9	11.3	10.9	10.5	24	21.3	18.7	17.3	16.1	15.3	14.8	14.3												
80	8.6	7.6	6.7	6.2	5.8	5.5	5.3	5.1	15.5	13.7	12	11.1	10.4	9.8	9.5	9.2	21.5	19.1	16.7	15.5	14.4	13.7	13.2	12.8												
90	7.5	6.7	5.8	5.4	5	4.8	4.6	4.5	14.1	12.6	11	10.2	9.5	9	8.7	8.4	19.9	17.7	15.4	14.3	13.4	12.7	12.2	11.8												
100	6.7	5.9	5.2	4.8	4.5	4.2	4.1	4	13.2	11.7	10.2	9.5	8.8	8.4	8.1	7.8	18.7	16.6	14.5	13.5	12.6	11.9	11.5	11.1												
125	6	5.3	4.7	4.3	4	3.8	3.7	3.6	11.6	10.3	9	8.4	7.8	7.4	7.1	6.9	16.9	15	13.1	12.2	11.3	10.7	10.4	10												
150	5.1	4.5	3.9	3.6	3.4	3.2	3.1	3	10.6	9.4	8.2	7.6	7.1	6.7	6.5	6.3	16.3	14.5	12.7	11.7	11	10.4	10	9.7												
200	4.3	3.8	3.3	3.1	2.9	2.7	2.6	2.6	9.3	8.3	7.3	6.7	6.3	5.9	5.7	5.6	14.5	12.9	11.3	10.4	9.7	9.2	8.9	8.6												
250	3.8	3.4	3	2.8	2.6	2.4	2.4	2.3	8.5	7.5	6.6	6.1	5.7	5.4	5.2	5	11.6	10.3	9	8.4	7.8	7.4	7.2	6.9												
300	3.5	3.1	2.7	2.5	2.4	2.2	2.2	2.1	7.4	6.5	5.7	5.3	4.9	4.7	4.5	4.4	9.8	8.7	7.6	7.1	6.6	6.2	6	5.8												

The Nominal Bursting Pressure of Seamless Pipe is calculated with the following formula:

$$P = \frac{2 \times S \times t}{D}$$

Where:

- P** = Pressure Rating (MPa)
- S** = Minimum Tensile Strength (MPa)
- t** = Wall thickness (mm)
- D** = Outside Diameter of Pipe (mm)

NOMINAL WORKING PRESSURE

TECHNICAL DATA FOR 304L & 316L SEAMLESS PIPE

NOMINAL BORE SIZE	SCHEDULE 10s										SCHEDULE 40s										SCHEDULE 80s										
	TEMPERATURE °C										TEMPERATURE °C										TEMPERATURE °C										
	50	100	150	200	250	300	350	400	50	100	150	200	250	300	350	400	50	100	150	200	250	300	350	400	50	100	150	200	250	300	350
6 1/8	25.1	21.9	19	17.5	16.2	15.2	14.7	14.1	35	30.5	26.5	24.4	22.6	21.2	20.6	19.7	48.7	42.6	36.9	34	31.5	29.5	28.7	27.4							
8 1/4	25.1	21.9	19	17.5	16.2	15.2	14.8	14.1	34	29.8	25.8	23.7	22	20.6	20	19.2	45.9	40.1	34.7	32	29.7	27.8	27	25.8							
10 3/8	20.1	17.6	15.2	14	13	12.2	11.8	11.3	28.1	24.6	21.3	19.6	18.2	17	16.5	15.8	39	34.1	29.5	27.2	25.2	23.6	22.9	21.9							
15 1/2	20.6	18	15.6	14.4	13.3	12.5	12.1	11.6	27.1	23.7	20.5	18.9	17.5	16.4	15.9	15.2	36.5	31.9	27.6	25.4	23.6	22.1	21.5	20.5							
20 3/4	16.5	14.4	12.4	11.5	10.6	10	9.7	9.3	27.4	19.6	16.9	15.6	14.5	13.5	13.2	12.6	30.5	26.7	23.1	21.3	19.7	18.5	17.9	17.2							
25 1	17.3	15.1	13.1	12	11.2	10.4	10.2	9.7	22.4	18.4	15.9	14.7	13.6	12.8	12.4	11.9	28.4	24.8	21.15	19.8	18.4	17.2	16.7	16							
32 1 1/4	13.7	11.9	10.3	9.5	8.8	8.3	8	7.7	21.1	15.4	13.3	12.3	11.4	10.6	10.3	9.9	23.9	20.9	18.1	16.7	15.5	14.5	14.1	13.5							
40 1 1/2	11.9	10.4	9	8.3	7.7	7.2	7	6.7	17.6	13.9	12	11.1	10.3	9.6	9.3	8.9	21.9	19.1	16.6	15.3	14.2	13.3	12.9	12.3							
50 2	9.6	8.4	7.2	6.7	6.2	5.8	5.6	5.4	15.9	11.8	10.2	9.4	8.7	8.2	7.9	7.6	19.1	16.7	14.5	13.3	12.4	11.6	11.3	10.8							
65 2 1/2	8.7	7.6	6.6	6.1	5.6	5.3	5.1	4.9	14.7	12.9	11.1	10.3	9.5	8.9	8.7	8.3	20	17.5	15.1	13.9	12.9	12.1	11.8	11.3							
80 3	7.1	6.2	5.4	5	4.6	4.3	4.2	4	12.9	11.2	9.7	9	8.3	7.8	7.6	7.2	17.9	15.6	13.5	12.4	11.6	10.8	10.5	10.1							
90 3 1/2	6.3	5.5	4.7	4.4	4	3.8	3.7	3.5	11.8	10.3	8.9	8.2	7.6	7.1	6.9	6.6	16.6	14.5	12.5	11.6	10.7	10	9.7	9.3							
100 4	5.6	4.9	4.2	3.9	3.6	3.4	3.3	3.1	11	9.6	8.3	7.7	7.1	6.6	6.5	6.2	15.6	13.6	11.8	10.9	10.1	9.4	9.2	8.8							
125 5	5	4.4	3.8	3.5	3.2	3	2.9	2.8	9.7	8.4	7.3	6.7	6.2	5.8	5.7	5.4	14	12.3	10.6	9.8	9.1	8.5	8.3	7.9							
150 6	4.2	3.7	3.2	2.9	2.7	2.5	2.5	2.4	8.8	7.7	6.7	6.1	5.7	5.3	5.2	5	13.6	11.9	10.3	9.5	8.8	8.2	8	7.6							
200 8	3.6	3.1	2.7	2.5	2.3	2.2	2.1	2	7.8	6.8	5.9	5.4	5	4.7	4.6	4.4	12.1	10.5	9.1	8.4	7.8	7.3	7.1	6.8							
250 10	3.2	2.8	2.4	2.2	2.1	1.9	1.9	1.8	7.1	6.2	5.3	4.9	4.6	4.3	4.2	4	9.7	8.5	7.3	6.8	6.3	5.9	5.7	5.5							
300 12	2.9	2.6	2.2	2	1.9	1.8	1.7	1.7	6.1	5.4	4.6	4.3	4	3.7	3.6	3.4	8.2	7.1	6.2	5.7	5.3	4.9	4.6	4.6							

The figures above are Nominal Working Pressure for 304L and 316L Seamless Stainless Steel Pipe under constant operating conditions, in MPa.

Where pressures or temperature fluctuations occur, increased safety factors should be adopted. Listed below are factors of safety recommended for varying pressure conditions.

- 5** To bursting pressure for no pressure fluctuations.
- 8** To bursting pressure for small/regular pressure fluctuations.
- 12** To bursting pressure for large/prolonged pressure fluctuations.

The figures given for nominal working pressures and factor of safety are for quick reference purposes only. Detailed design calculations should be in accordance with the applicable design standard.

WELDED PIPE

Nominal working pressure can be calculated by multiplying the figures in the tables by 0.85 (Weld Joint Efficiency factor).

BUTTWELD PIPE FITTINGS

SPECIFICATIONS:	ASTM A403
	ANSI B16.9
MATERIAL:	WELDED / SEAMLESS



SIZE		90° ELBOW				45° ELBOW		EQUAL		STUB END		CAPS
		LONG RADIUS		SHORT RADIUS		LONG RADIUS		TEE		TYPE B		
Inch	mm	304L	316L	304L	316L	304L	316L	304L	316L	304L	316L	316L
SCHEDULE 10												
1/2	15	★	★	☆	☆	★	★	★	★	☆	★	★
3/4	20	★	★	☆	☆	★	★	★	★	☆	★	★
1	25	★	★	☆	★	★	★	★	★	☆	★	★
1 1/4	32	★	★	☆	☆	★	★	★	★	☆	★	★
1 1/2	40	★	★	☆	★	★	★	★	★	☆	★	★
2	50	★	★	★	★	★	★	★	★	★	★	★
2 1/2	65	★	★	☆	☆	★	★	★	★	★	★	★
3	80	★	★	☆	☆	★	★	★	★	★	★	★
3 1/2	90	☆	★	☆	☆	☆	☆	☆	☆	☆	☆	☆
4	100	★	★	★	★	★	★	★	★	☆	★	★
5	125	★	★	☆	☆	☆	★	★	★	★	★	★
6	150	★	★	★	★	★	★	★	★	☆	★	★
8	200	★	★	★	★	★	★	★	★	★	★	★
10	250	★	★	☆	☆	★	★	★	★	☆	★	★
12	300	★	★	☆	☆	☆	★	★	★	☆	★	★
14	350	★	★	☆	☆	☆	☆	☆	☆	☆	☆	☆
16	400	★	★	☆	☆	☆	☆	☆	★	☆	★	☆
18	450	☆	★	☆	☆	☆	☆	☆	☆	☆	☆	☆
20	500	☆	★	☆	☆	☆	☆	☆	☆	☆	☆	☆
24	600	☆	★	☆	☆	☆	☆	☆	☆	☆	☆	☆
SCHEDULE 40												
1/2	15	★	★	☆	☆	★	★	★	★	☆	★	☆
3/4	20	★	★	☆	☆	★	★	★	★	☆	★	★
1	25	★	★	☆	☆	★	★	★	★	★	★	★
1 1/4	32	★	★	☆	☆	★	★	★	★	☆	★	★
1 1/2	40	★	★	☆	★	★	★	★	★	★	★	★
2	50	★	★	☆	★	★	★	★	★	★	★	★
2 1/2	65	★	★	☆	☆	★	★	★	★	☆	★	★
3	80	★	★	☆	★	★	★	★	★	☆	★	★
3 1/2	90	☆	★	☆	☆	☆	☆	☆	☆	☆	☆	☆
4	100	★	★	☆	★	★	★	★	★	★	★	★
5	125	★	★	☆	☆	☆	★	☆	★	☆	☆	★
6	150	★	★	☆	★	★	★	★	★	★	★	★
8	200	★	★	☆	☆	★	★	★	★	★	★	★
10	250	★	★	☆	☆	☆	★	★	★	☆	☆	★
12	300	★	★	☆	☆	☆	★	★	★	☆	☆	★
14	350	☆	☆	☆	☆	☆	☆	☆	☆	☆	☆	☆
16	400	★	★	☆	☆	☆	☆	☆	☆	☆	☆	☆
20	500	☆	☆	☆	☆	☆	☆	☆	☆	☆	☆	☆
24	600	☆	☆	☆	☆	☆	☆	☆	☆	☆	☆	☆
SCHEDULE 80												
1	25		★									
1 1/2	40		★									
2	50		★									
2 1/2	65		★									
3	80		★									
4	100		★									
6	150		★									

NOTE: OTHER SCH 80 FITTINGS ARE AVAILABLE ON REQUEST

REDUCING BUTTWELD PIPE FITTINGS

SPECIFICATIONS: ASTM A403

ANSI B16.9

MATERIAL: WELDED / SEAMLESS



SIZE		CONCENTRIC REDUCER				ECCENTRIC REDUCER		REDUCING TEE	
Inch	mm	SCH 10		SCH 40		SCH 10	SCH 40	SCH10	SCH 40
		304L	316L	304L	316L	316L	316L	316L	316L
3/4 x 1/2	20 x 15	★	★	☆	★	☆	★	☆	☆
1 x 1/2	25 x 15	★	★	★	★	☆	★	☆	☆
1 x 3/4	25 x 20	★	★	★	★	★	★	☆	☆
1 1/4 x 1/2	32 x 15	☆	★	☆	★	☆	☆		
1 1/4 x 3/4	32 x 20	☆	★	★	★	☆	☆	☆	☆
1 1/4 x 1	32 x 25	★	★	★	★	★	★	☆	☆
1 1/2 x 1/2	40 x 15	☆	★	★	★	☆	☆		
1 1/2 x 3/4	40 x 20	★	★	☆	★	★	★	★	☆
1 1/2 x 1	40 x 25	★	★	★	★	★	★	★	★
1 1/2 x 1 1/4	40 x 32	★	★	☆	★	★	★	☆	☆
2 x 3/4	50 x 20	☆	☆	☆	★	☆	☆	☆	☆
2 x 1	50 x 25	★	★	★	★	★	★	★	★
2 x 1 1/4	50 x 32	★	★	☆	★	★	★	☆	☆
2 x 1 1/2	50 x 40	★	★	★	★	★	★	★	★
2 1/2 x 1	65 x 25	☆	★	☆	★	☆	☆	☆	☆
2 1/2 x 1 1/4	65 x 32	☆	☆	☆	☆	☆	☆	☆	☆
2 1/2 x 1 1/2	65 x 40	☆	★	☆	★	★	★	☆	☆
2 1/2 x 2	65 x 50	★	★	★	★	★	★	★	☆
3 x 1	80 x 25	★	★	☆	★	☆	☆	☆	☆
3 x 1 1/4	80 x 32	☆	☆	☆	☆	☆	☆	☆	☆
3 x 1 1/2	80 x 40	★	★	☆	★	★	★	★	★
3 x 2	80 x 50	★	★	★	★	★	★	★	★
3 x 2 1/2	80 x 65	★	★	☆	★	★	★	★	☆
3 1/2 x 1 1/2	90 x 40	☆	☆	☆	☆	☆	☆	☆	☆
3 1/2 x 2	90 x 50	☆	☆	☆	☆	☆	☆	☆	☆
3 1/2 x 2 1/2	90 x 65	☆	☆	☆	☆	☆	☆	☆	☆
3 1/2 x 3	90 x 80	☆	☆	☆	☆	☆	☆	☆	☆
4 x 1 1/2	100 x 40	☆	★	☆	☆	☆	★	☆	☆
4 x 2	100 x 50	★	★	★	★	★	★	★	☆
4 x 2 1/2	100 x 65	★	★	☆	★	★	★	★	☆
4 x 3	100 x 80	★	★	★	★	★	★	★	★
4 x 3 1/2	100 x 90	☆	☆	☆	☆	☆	☆	☆	☆
5 x 2	125 x 50	☆	★	☆	☆	☆	☆	☆	☆
5 x 2 1/2	125 x 65	☆	☆	☆	☆	☆	☆	☆	☆
5 x 3	125 x 80	☆	★	☆	☆	★	☆	☆	☆
5 x 3 1/2	125 x 90	☆	☆	☆	☆	☆	☆	☆	☆
5 x 4	125 x 100	★	★	☆	☆	★	☆	☆	☆
6 x 2	150 x 50	☆	☆	☆	★	☆	☆	☆	☆
6 x 2 1/2	150 x 65	☆	☆	☆	☆	☆	☆	☆	☆
6 x 3	150 x 80	★	★	★	★	★	★	★	☆
6 x 3 1/2	150 x 90	☆	☆	☆	☆	☆	☆	☆	☆
6 x 4	150 x 100	★	★	★	★	★	★	★	☆
6 x 5	150 x 125	★	★	☆	★	★	★	☆	☆
8 x 3	200 x 80	☆	☆	☆	☆	☆	☆	☆	☆
8 x 3 1/2	200 x 90	☆	☆	☆	☆	☆	☆	☆	☆
8 x 4	200 x 100	★	★	★	★	★	★	☆	★
8 x 5	200 x 125	☆	☆	☆	☆	☆	☆	☆	☆
8 x 6	200 x 150	★	★	★	★	★	★	★	☆
10 x 4	250 x 100	☆	☆	☆	☆	☆	☆	☆	☆
10 x 5	250 x 125	☆	☆	☆	☆	☆	☆	☆	☆
10 x 6	250 x 150	☆	★	☆	★	★	☆	☆	☆
10 x 8	250 x 200	★	★	☆	★	★	★	☆	☆
12 x 5	300 x 125	☆	☆	☆	☆	☆	☆	☆	☆
12 x 6	300 x 150	☆	☆	☆	☆	☆	☆	☆	☆
12 x 8	300 x 200	★	★	☆	★	★	★	☆	☆
12 x 10	300 x 250	★	★	☆	★	★	☆	☆	☆

TECHNICAL DATA

BUTTWELD PIPE FITTING DIMENSIONS

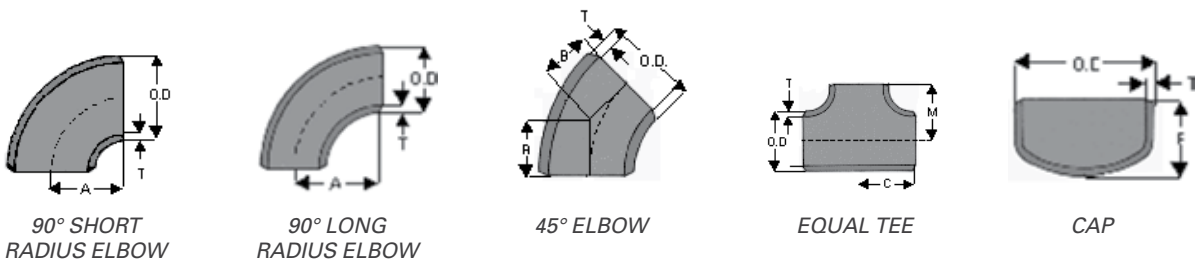

NOMINAL PIPE SIZE		OUTSIDE DIAMETER	WALL THICKNESS SCHEDULE				ELBOW			EQUAL TEE	CAP
							90°		45°		
		T				L/R	S/R	L/R			
Inch	mm	O.D.	5S	10S	40S	80S	A	A	B	C,M	E
1/2	15	21.3	1.65	2.11	2.77	3.73	38.1		16	25.4	25.4
3/4	20	26.7	1.65	2.11	2.87	3.91	38.1		11.2	28.6	25.4
1	25	33.4	1.65	2.77	3.38	4.55	38.1	25.4	22	38.1	38
1 1/4	32	42.2	1.65	2.77	3.56	4.85	47.5	32	25.4	47.6	38
1 1/2	40	48.3	1.64	2.77	3.68	5.08	57.1	38	28.6	57.2	38
2	50	60.3	1.65	2.77	3.91	5.54	76.2	51	35	63.5	38
2 1/2	65	73	2.11	3.05	5.16	7.01	95.2	63.5	44.5	76.2	38
3	80	88.9	2.11	3.05	5.49	7.62	114.5	76	51	85.7	51
3 1/2	90	101.6	2.11	3.05	5.74	8.08	133.5	89	57	95.3	64
4	100	114.3	2.11	3.05	6.02	8.56	152.5	101.5	63.5	104.8	64
5	125	141.3	2.77	3.4	6.55	9.52	190.5	127	79.3	123.8	76
6	150	168.3	2.77	3.4	7.11	10.97	228.5	152.5	95.2	142.9	89
8	200	219.1	2.77	3.76	8.18	12.7	305	203	127	177.8	102
10	250	273	3.4	4.19	9.27	12.7	381	254	159	215.9	127
12	300	323.9	3.96	4.57	9.52	12.7	457	305	190.5	254	152
14	350	355.6	3.97	4.78	9.53	12.7	533	356	222	279	165
16	400	406.4	4.19	4.78	9.53	12.7	610	406	254	305	178
18	450	457.2	4.19	4.78	9.53	12.7	686	457	286	343	203
20	500	508	4.78	5.54	9.53	12.7	762	508	318	381	229
24	600	609.6	5.54	6.35	9.53	12.7	914	610	381	432	267

NOMINAL PIPE SIZE		OUTSIDE DIAMETER	STUB END TYPE B		
			MSS		
Inch	mm	O.D.	G	F	R
1/2	15	21.3	35	51	0.8
3/4	20	26.7	43	51	0.8
1	25	33.4	51	51	0.8
1 1/4	32	42.2	64	51	0.8
1 1/2	40	48.3	73	51	0.8
2	50	60.3	92	64	0.8
2 1/2	65	73	105	64	0.8
3	80	88.9	127	64	0.8
3 1/2	90	101.6	140	76	0.8
4	100	114.3	157	76	1.6
5	125	141.3	186	76	1.6
6	150	168.3	216	89	1.6
8	200	219.1	270	102	1.6
10	250	273	324	127	1.6
12	300	323.9	381	152	1.6
14	350	355.6	413	152	1.6
16	400	406.4	470	152	1.6
18	450	457.2	533	152	1.6
20	500	508	584	152	1.6
24	600	609.6	692	152	1.6

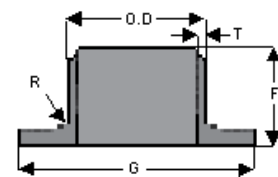

TECHNICAL DATA

BUTTWELD PIPE FITTING DIMENSIONS

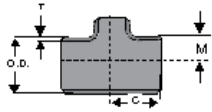

REDUCING TEE



CONCENTRIC REDUCER



ECCENTRIC REDUCER

NOMINAL PIPE SIZE		REDUCING TEE		REDUCERS CONCENTRIC & ECCENTRIC
Inch	mm	C	M	H
3/4 x 1/2	20 x 15	28.6	28.6	38.1
1 x 1/2	25 x 15	38.1	38.1	50.8
	25 x 20		38.1	
1 1/4 x 1/2	32 x 15	47.6	47.6	50.8
	32 x 20		47.6	
	32 x 25		47.6	
1 1/2 x 1/2	40 x 15	57.2	57.2	63.5
	40 x 20		57.2	
	40 x 25		57.2	
	40 x 32		57.2	
2 x 3/4	50 x 20	63.5	44.5	76.2
	50 x 25		50.8	
	50 x 32		57.2	
	50 x 40		60.3	
	50 x 50		63.5	
2 1/2 x 1	65 x 25	76.2	57.2	88.9
	65 x 32		63.5	
	65 x 40		66.7	
	65 x 50		69.9	
3 x 1	80 x 25	85.7	66.7	88.9
	80 x 32		69.9	
	80 x 40		73	
	80 x 50		76.2	
	80 x 65		82.6	
	80 x 80		85.7	
3 1/2 x 1 1/2	90 x 40	95.3	79.4	101.6
	90 x 50		82.6	
	90 x 65		88.9	
	90 x 80		92.1	
4 x 1 1/2	100 x 40	104.8	85.7	101.6
	100 x 50		88.9	
	100 x 65		95.3	
	100 x 80		98.4	
	100 x 90		101.6	
	100 x 100		104.8	
5 x 2	125 x 50	123.8	104.8	127
	125 x 65		108	
	125 x 80		111.1	
	125 x 90		114.3	
	125 x 100		117.5	
6 x 2	150 x 50	142.9	117.5	139.7
	150 x 65		120.7	
	150 x 80		123.8	
	150 x 90		127	
	150 x 100		130.1	
	150 x 125		136.5	
8 x 3	200 x 80	178	149.1	152
	200 x 90		152	
	200 x 100		155	
	200 x 125		162	
	200 x 150		168	
	200 x 200		178	
10 x 4	250 x 100	216	184	178
	250 x 125		191	
	250 x 150		194	
	250 x 200		203	
12 x 5	300 x 125	254	216	203
	300 x 150		219	
	300 x 200		229	
	300 x 250		241	

150LB BSP THREADED FITTINGS

SPECIFICATIONS: ASTM A351-77

GRADE: 316

THREAD: BSP (MALE-TAPER, FEMALE PARALLEL)

PRESSURE: NOMINAL 1000kPA
WORKING 2000kPA TEST



Inch	mm	SOCKET ROUND	NIPPLE HEX	BARRELL NIPPLE	TOE NIPPLE	UNION 3 PCE	ELBOW 90° FEM	ELBOW 90° M/F	ELBOW 45° F/F	TEE FEM	HEX CAP	HEX PLUG	LOCK NUT	HOSE TAIL
1/8	6	★	★	★	★	★	★	★	☆	★	★	★	★	★
1/4	8	★	★	★	★	★	★	★	★	★	★	★	★	★
3/8	10	★	★	★	★	★	★	★	★	★	★	★	★	★
1/2	15	★	★	★	★	★	★	★	★	★	★	★	★	★
3/4	20	★	★	★	★	★	★	★	★	★	★	★	★	★
1	25	★	★	★	★	★	★	★	★	★	★	★	★	★
1 1/4	32	★	★	★	★	★	★	★	★	★	★	★	★	★
1 1/2	40	★	★	★	★	★	★	★	★	★	★	★	★	★
2	50	★	★	★	★	★	★	★	★	★	★	★	★	★
2 1/2	65	★	★	★	★	★	★	★	★	★	★	★	★	★
3	80	★	★	★	★	★	★	★	★	★	★	★	★	★
4	100	★	★	★	★	★	★	★	☆	★	★	★	★	☆
6	150	☆	☆	☆	☆	☆	☆	☆	☆	☆	☆	☆	☆	☆



Inch	mm	HEX REDUCING BUSH	HEX REDUCING NIPPLE	REDUCING SOCKET
1/4 x 1/8	8 x 6	★	★	★
3/8 x 1/8	10 x 6	★	★	★
3/8 x 1/4	10 x 8	★	★	★
1/2 x 1/8	15 x 6	★	★	★
1/2 x 1/4	15 x 8	★	★	★
1/2 x 3/8	15 x 10	★	★	★
3/4 x 1/8	20 x 6	★	★	☆
3/4 x 1/4	20 x 8	★	★	★
3/4 x 1/8	20 x 10	★	★	★
3/4 x 1/2	20 x 15	★	★	★
1 x 1/4	25 x 8	★	★	☆
1 x 3/8	25 x 10	★	★	☆
1 x 1/2	25 x 15	★	★	★
1 x 3/4	25 x 20	★	★	★
1 1/4 x 3/8	32 x 10	★	★	☆
1 1/4 x 1/2	32 x 15	★	★	★
1 1/4 x 3/4	32 x 20	★	★	★
1 1/4 x 1	32 x 25	★	★	★
1 1/2 x 1/2	40 x 15	★	★	☆
1 1/2 x 3/4	40 x 20	★	★	★
1 1/2 x 1	40 x 25	★	★	★
1 1/2 x 1 1/4	40 x 32	★	★	★
2 x 3/4	50 x 20	★	★	☆
2 x 1	50 x 25	★	★	★
2 x 1 1/4	50 x 32	★	★	★
2 x 1 1/2	50 x 40	★	★	★
2 1/2 x 1 1/4	65 x 32	★	★	☆
2 1/2 x 2	65 x 50	★	★	☆
3 x 2	80 x 50	★	★	★
3 x 2 1/2	80 x 65	★	★	☆
4 x 3	100 x 80	★	★	☆

150LB BSP THREADED FITTINGS TECHNICAL DATA

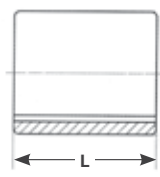

SOCKET

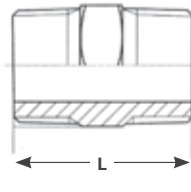

HEX NIPPLE

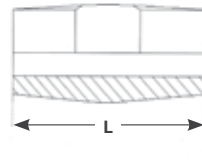

BARREL NIPPLE



TOE NIPPLE

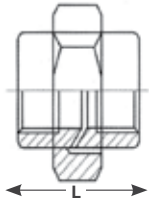

UNION 3 PCE F/F

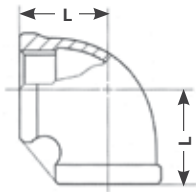

ELBOW 90Deg F/F

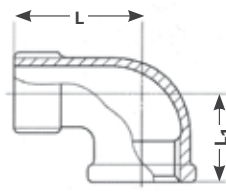

ELBOW 90Deg M/F

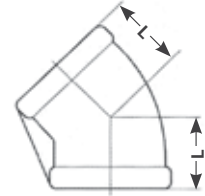

ELBOW 45Deg F/F

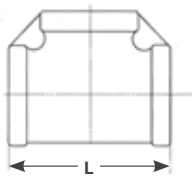

TEE F/F

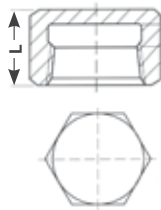

HEXAGON CAP



HEXAGON PLUG

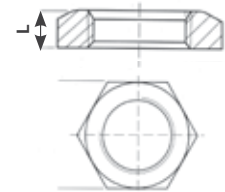

LOCK NUT

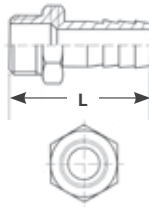

HOSE TAIL



HEX REDUCING BUSH

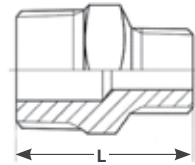

HEX REDUCING NIPPLE

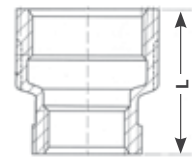

REDUCING SOCKET

SIZE mm	6		8		10		15		20		25		32		40		50		65		80		100	
LENGTH mm	L	L ₁	L	L ₁	L	L ₁	L	L ₁	L	L ₁	L	L ₁	L	L ₁	L	L ₁	L	L ₁	L	L ₁	L	L ₁	L	L ₁
FITTING																								
Socket	20		25		26		34		36		43		48		48		56		65		71		83	
Hexagon Nipple	31		33		42		50		51		63		59		64		68		73		86		90	
Barrel Nipple	40		40		40		60		60		60		80		80		100		100		120		120	
Toe Nipple	30		30		30		35		40		40		50		50		50		60		70		80	
Union 3 Pce F/F	37		37		39		41		42		51		52		56		60		75		89		99	
Elbow 90Deg F/F	17		19.5		24		29		32		37		44		48		55.5		67		77		96	
Elbow 90Deg M/F	18	26	21	29	24	36	27	41	33	47	37	53	44	63	47	69	59	80	66	105	77	113	98	130
Elbow 45Deg F/F	16		17		19		21		24		28		33		36		42		49		54		65	
Tee F/F	18		19.5		23		29		32.5		37		45		48		56.5		68		79		97	
Hexagon Cap	16		20		21		22.5		23		26		29		32		35		42		46		55	
Hexagon Plug	17		18		23.5		28		28		34		35		36		37.5		40		45		51	
Lock Nut	8.5		8.5		9		9		10		11		12		13		13.5		18		21		22	
Hose Tail			46.5		51.5		62.5		72.5		82		80		93		110		136		147		158	
Hex Reducing Bush			22.5		23		25.5		26.5		33.5		34		36		36		49		50		51	
Hex Reducing Nipple			31.5		35		39		42		46		52		53		58		65		73		83	
Reducing Socket			28.5		41		45		45		50		50		57		67		76		85		96	

150LB BSP THREADED FITTINGS TECHNCIAL DATA

BRITISH STANDARD THREADS (BSP)

Taper 1 in 16 on diagram (Shown exaggerated in diagram)

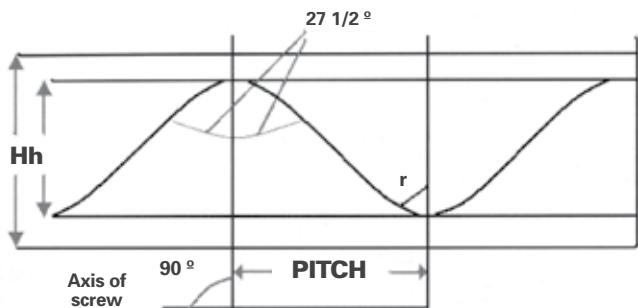

Taper

- $H = 0.960237xp$
- $h = 0.610327xp$
- $r = 0.127278xp$

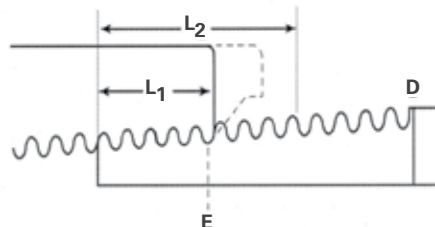

NOMINAL BORE OF PIPE		OUTSIDE DIAMETER OF S.S. PIPE	NUMBER OF THREADS PER INCH	PITCH	DEPTH OF THREAD	DIAMETER AT GAUGE PLANE (GAUGE DIA.)	DISTANCE OF GAUGE DIA. (GAUGE LENGTH)	LENGTH OF USEFUL THREAD
NB	Inch	D			h	E	L ₁	L ₂
6	1/8	0.405	28	0.03571	0.0229	0.383	0.1563	0.2545
8	1/4	0.540	19	0.05263	0.0337	0.518	0.2367	0.3314
10	3/8	0.675	19	0.05263	0.0337	0.656	0.2500	0.3947
15	1/2	0.840	14	0.07143	0.0457	0.825	0.3214	0.5178
20	3/4	1.050	14	0.07143	0.0457	1.041	0.3750	0.5714
25	1	1.315	11	0.09091	0.0582	1.309	0.4091	0.6591
32	1 1/4	1.660	11	0.09091	0.0582	1.650	0.5000	0.7500
40	1 1/2	1.900	11	0.09091	0.0582	1.882	0.5000	0.7500
50	2	2.375	11	0.09091	0.0582	2.347	0.6250	0.9204
65	2 1/2	2.875	11	0.09091	0.0582	2.950	0.6875	1.0511
80	3	3.500	11	0.09091	0.0582	3.460	0.8125	1.1761
100	4	4.500	11	0.09091	0.0582	4.450	1.0000	1.4091
125	5	5.563	11	0.09091	0.0582	5.40	1.1250	1.5795
150	6	6.625	11	0.09091	0.0582	6.450	1.1250	1.5795

3000LB FITTINGS

SPECIFICATIONS: ASTM A182/ANSI B16/11
NPT THREAD

GRADE: 316

PRESSURE: 3000LB (ICPA)



Inch	mm	FULL COUPLING	HALF COUPLING	UNION 3 PCE	90° ELBOW FEMALE	45° ELBOW FEMALE	TEE FEMALE	HEX NIPPLE	HEX PLUG
1/8	6	★	☆	★	☆	☆	☆	★	★
1/4	8	★	☆	★	★	☆	★	★	★
3/8	10	★	☆	★	★	☆	★	★	★
1/2	15	★	☆	★	★	☆	★	★	★
3/4	20	★	☆	★	★	☆	★	★	★
1	25	★	☆	★	★	☆	★	★	★
1 1/4	32	★	☆	★	★	☆	★	★	★
1 1/2	40	★	☆	★	★	☆	★	★	★
2	50	★	☆	★	★	☆	★	★	★



SIZE - NOMINAL		HEX REDUCING BUSH	HEX REDUCING NIPPLE
Inch	mm		
1/4 x 1/8	8 x 6	★	★
3/8 x 1/8	10 x 6	★	★
3/8 x 1/4	10 x 8	★	★
1/2 x 1/4	15 x 8	★	★
1/2 x 3/8	15 x 10	★	★
3/4 x 1/2	20 x 15	★	★
1 x 1/4	25 x 8	★	★
1 x 1/2	25 x 15	★	★
1 x 3/4	25 x 20	★	★
1 1/4 x 3/4	32 x 20	★	★
1 1/4 x 1	32 x 25	★	★
1 1/2 x 3/4	40 x 20	★	★
1 1/2 x 1	40 x 25	★	★
2 x 3/4	50 x 20	★	★
2 x 1	50 x 25	★	★
2 x 1 1/2	50 x 40	★	★

SPECIFICATIONS: ASTM A182/ANSI B16/11
3000LB SOCKETWELD

GRADE: 316

PRESSURE: 3000LB (ICPA)



SCHEDULE - NOMINAL		FULL COUPLING	HALF COUPLING	UNION 3 PCE	90° ELBOW FEMALE	45° ELBOW FEMALE	EQUAL TEE FEMALE	CAP
Inch	mm							
1/4	8	☆	☆	☆	☆	☆	☆	☆
3/8	10	☆	☆	☆	☆	☆	☆	☆
1/2	15	☆	☆	☆	☆	☆	☆	☆
3/4	20	☆	☆	☆	☆	☆	☆	☆
1	25	☆	☆	☆	☆	☆	☆	☆
1 1/4	32	☆	☆	☆	☆	☆	☆	☆
1 1/2	40	☆	☆	☆	☆	☆	☆	☆
2	50	☆	☆	☆	☆	☆	☆	☆

3000LB NPT THREADED FITTINGS TECHNICAL DATA

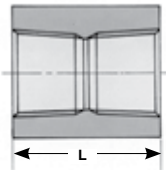

FULL COUPLING

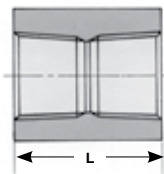

HALF COUPLING

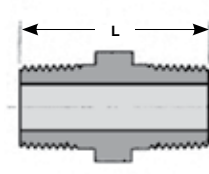

HEXAGON NIPPLE

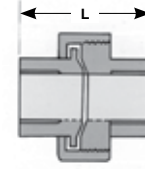

UNION 3 PCE F/F

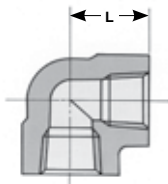

ELBOW 90 DEG F/F

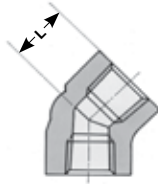

ELBOW 45 DEG F/F

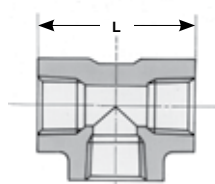

TEE F/F

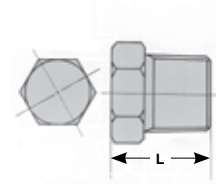

HEXAGON PLUG

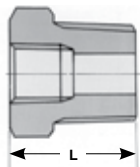

HEX REDUCING BUSH

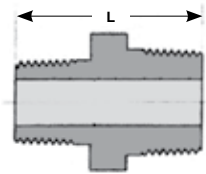

HEX REDUCING NIPPLE

3000LB NPT THREADED FITTINGS
TECHNICAL DATA

SIZE mm	6	8	10	15	20	25	32	40	50
LENGTH mm	L	L	L	L	L	L	L	L	L
FITTING									
Full Coupling	32	35	38	48	51	60	67	79	86
Half Coupling	16	17.5	19	24	25.5	30	33.5	39.5	43
Hexagon Nipple	26	36	36	47	48	59	60	62	68
Union 3 Pce F/F	41.4	41.4	46	49	56.9	62	71.1	76.5	86.1
Elbow 90 Deg F/F	21	25	28	33	38	44	51	60	64
Elbow 45 Deg F/F	17	19	22	25	28	33	35	43	44
Tee F/F	21	25	28	33	38	44	51	60	64
Hexagon Plug	16	17	21	22	26	29	31	37	38
Hex Reducing Bush		14	17	19	22	25	28	29	31
Hex Reducing Nipple			19	24	30	35	46	50	65

TECHNICAL DATA

DIMENSIONS OF PIPE THREAD

AMERICAN STANDARD THREADS (NPT)

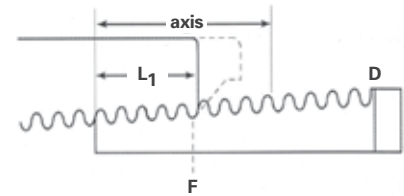
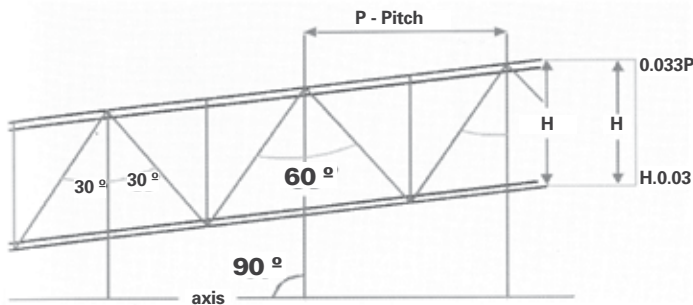

Taper

$$L_2 = (0.8D - 6.8)1/n$$

Straight Pipe Threads: the pitch, angle and depth of thread are the same as the corresponding dimensions of the taper threads

NOMINAL BORE OF PIPE		OUTSIDE DIAMETER OF S.S. PIPE	NUMBER OF THREADS PER INCH	PITCH	HAND TIGHT	EFFECTIVE ENGAGEMENT EXTERNAL	THREAD LENGTH THREAD	DEPTH
NB	Inch	D	n	P	L ₁	E ₁	L ₂	h
6	1/8	0.405	27	0.03704	0.180	0.37476	0.2639	0.02963
8	1/4	0.540	18	0.05556	0.200	0.48989	0.4018	0.04444
10	3/8	0.675	18	0.05556	0.240	0.62701	0.4078	0.04444
15	1/2	0.840	14	0.07143	0.230	0.77843	0.5337	0.05714
20	3/4	1.050	14	0.07143	0.339	0.98887	0.5457	0.05714
25	1	1.315	11 1/2	0.08696	0.400	1.23863	0.6828	0.06957
32	1 1/4	1.660	11 1/2	0.08696	0.420	1.56338	0.7068	0.06957
40	1 1/2	1.900	11 1/2	0.08696	0.420	1.82234	0.7235	0.06957
50	2	2.375	11 1/2	0.08696	0.436	2.29627	0.7665	0.06957
65	2 1/2	2.875	8	0.12500	0.682	2.76216	1.1375	0.10000
80	3	3.500	8	0.12500	0.766	3.38850	1.2000	0.10000
90	3 1/2	4.000	8	0.12500	0.821	3.88881	1.2500	0.10000
100	4	4.500	8	0.12500	0.844	4.38712	1.3000	0.10000
125	5	5.563	8	0.12500	0.937	5.44929	1.4063	0.10000
150	6	6.625	8	0.12500	0.958	6.50597	1.5121	0.10000

TECHNICAL DATA

SOCKET WELD FITTINGS

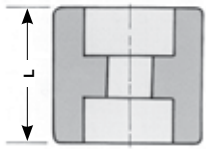

FULL COUPLING

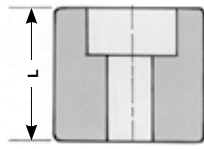

HALF COUPLING

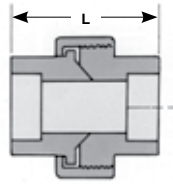

UNION 3 PCE F/F

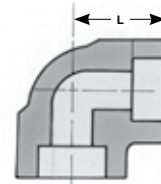

ELBOW 90 DEG F/F

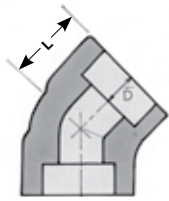

ELBOW 45 DEG F/F

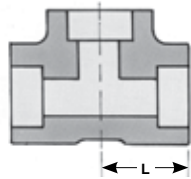

TEE F/F

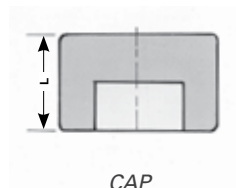

CAP

SIZE mm	6	8	10	15	20	25	32	40	50
LENGTH mm	L	L	L	L	L	L	L	L	L
FITTING									
Full Coupling	25.4	25.4	28.7	35	38.1	44.5	47.8	50.8	63.5
Half Coupling	25.4	25.4	28.7	35	38.1	44.5	47.8	50.8	63.5
Union 3 Pce F/F	41.4	41.4	46	49.3	57.2	63.5	71.4	76.2	85.9
Elbow 90 Deg F/F	20.6	20.6	24.7	28.7	33.3	38.1	44.5	50.8	60.5
Elbow 45 Deg F/F	17.5	17.5	19	22.4	25.4	28.7	33.3	35	42.4
Tee F/F	20.6	20.6	24.7	28.7	33.3	38.1	44.5	50.8	60.5
Cap	17.5	17.5	19	22.4	24.4	27	30.3	31.8	38.1

FORGED FLANGES

SPECIFICATIONS: ASTM A182 ANSI B16.5
RAISED FACE FLANGES

TYPE: SLIP ON RFSO
WELD NECK RFWN SCH10,40 & 80
BLIND RFB

CLASS: 150LB, 300LB, 600LB

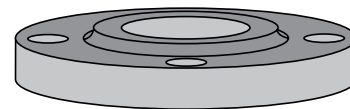

GRADE	SIZE N.B.	SLIP ON RAISED FACE			WELD NECK RAISED FACE			BLIND RAISED FACE		
		150lb	300lb	600lb	150lb	300lb	600lb	150lb	300lb	600lb
304L	mm									
	15	★	☆	☆	☆	☆	☆	☆	☆	☆
	20	★	☆	☆	☆	☆	☆	★	☆	☆
	25	★	★	☆	★	★	☆	★	☆	☆
	32	★	☆	☆	★	☆	☆	★	☆	☆
	40	★	★	☆	★	☆	☆	★	★	☆
	50	★	★	☆	★	★	☆	★	★	☆
	65	★	☆	☆	★	☆	☆	★	☆	☆
	80	★	★	☆	★	★	☆	★	★	☆
	100	★	★	☆	★	★	☆	★	★	☆
	150	★	★	☆	★	★	☆	★	★	☆
	200	★	☆	☆	★	★	☆	★	☆	☆
250	★	☆	☆	☆	☆	☆	☆	☆	☆	
300	☆	☆	☆	☆	☆	☆	☆	☆	☆	
316L	15	★	☆	☆	☆	☆	☆	★	☆	☆
	20	★	☆	☆	★	☆	☆	★	☆	☆
	25	★	★	☆	★	★	☆	★	★	☆
	32	★	★	☆	★	☆	☆	★	★	☆
	40	★	★	☆	★	★	☆	★	★	☆
	50	★	★	☆	★	★	☆	★	★	☆
	65	★	★	☆	★	★	☆	★	★	☆
	80	★	★	☆	★	★	☆	★	★	☆
	100	★	★	☆	★	★	☆	★	★	☆
	125	★	☆	☆	★	☆	☆	★	☆	☆
	150	★	★	☆	★	★	☆	★	★	☆
	200	★	★	☆	★	☆	☆	★	☆	☆
	250	★	☆	☆	★	☆	☆	★	☆	☆
	300	★	☆	☆	☆	☆	☆	★	☆	☆
	350	★	☆	☆	☆	☆	☆	★	☆	☆
	400	★	☆	☆	☆	☆	☆	★	☆	☆
	450	☆	☆	☆	☆	☆	☆	☆	☆	☆
	500	★	☆	☆	☆	☆	☆	☆	☆	☆
600	★	☆	☆	☆	☆	☆	☆	☆	☆	

TECHNICAL DATA

FORGED FLANGE DIMENSIONS

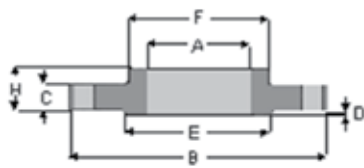

SLIP-ON

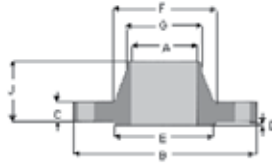

WELD NECK

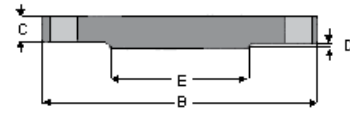

BLIND

BOLT	SIZE	OUTSIDE DIA. OF PIPE	OUTSIDE DIA. MIN.	THICK. MIN.	RAISED FACE THICK.	RAISED FACE DIA.	HUB DIA.	HUB DIA. BEGIN OF CHAMFER	LENGTH/HUB SLIP-ON W.NECK	BOLT CIRCLE DIA.	BOLT HOLE DIA.	# HOLES	
	mm	A	B	C	D	E	F	G	H	J	K	L	M
150lb	15	21.3	90	11.5	1.6	34.9	30	21.5	16	48	60.5	16	4
	20	26.9	98	13	1.6	42.9	38	26.5	16	52	70	16	4
	25	33.7	108	14.5	1.6	50.8	49	34.5	17	56	79.5	16	4
	32	42.2	117	16	1.6	63.5	59	43	21	57	89	16	4
	40	48.3	127	17.5	1.6	73	65	48.5	22	62	98.5	16	4
	50	60.3	152	19.5	1.6	92.1	78	62	25	64	120.5	20	4
	65	73	178	25	1.6	104.8	90	74.7	29	70	139.5	20	4
	80	88.9	191	25	1.6	127	108	91	30	70	152.5	20	4
	100	114.3	229	25	1.6	157.2	135	116	32	76	190.5	20	8
	150	168.3	279	25.5	1.6	215.9	192	178	40	89	241.5	23	8
	200	219.1	343	29	1.6	269.9	246	229	44	102	298.5	23	8
	250	273	406	30.5	1.6	323.8	305	276	49	102	362	26	12
	300	323.9	483	32.0	1.6	381.0	365	324.0	56	114	432.0	26	12
	350	355.6	535	35.0	1.6	412.8	400	355.5	57	127	476.5	29	12
	400	406.4	600	37.0	1.6	469.9	457	406.5	64	127	540.0	29	16
	450	457.2	635	40.0	1.6	533.4	505	457.0	68	140	578.0	32	16
	500	508.0	700	43.0	1.6	584.2	559	508.0	73	145	635.0	32	20
	600	600.6	815	48	1.6	692.2	664	609.5	83	152	749.5	35	20
300lb	15	21.3	95	14.5	1.6	34.9	38	21.5	22	52	66.5	16	4
	20	26.9	117	16	1.6	42.9	48	26.5	25	57	82.5	20	4
	25	33.7	124	17.5	1.6	50.8	54	33.5	27	62	89	20	4
	32	42.2	133	19.5	1.6	63.5	64	42	27	65	98.5	20	4
	40	48.3	156	21	1.6	73	70	48.5	30	68	114.5	23	4
	50	60.3	165	22.5	1.6	92.1	84	60.5	33	70	127	20	8
	65	73	191	25	1.6	104.8	100	73	38	76	149	23	8
	80	88.9	210	29	1.6	127	118	89	43	79	168.5	23	8
	100	114.3	254	30	1.6	157.2	146	114.5	48	86	200	23	8
	150	168.3	318	37	1.6	215.9	206	168.5	52	98	270	23	12
	200	219.1	381	41.5	1.6	269.9	260	219	62	111	330	26	12
	250	273	445	48	1.6	323.8	321	273	67	117	387.5	29	16
	300	323.9	520	51.0	1.6	381.0	375	324.0	73	130	451.0	32	16
	350	355.6	585	54.0	1.6	412.8	426	355.5	76	143	514.5	32	20
	400	406.4	650	57.5	1.6	469.9	483	406.5	83	146	571.5	35	20
	450	457.2	710	60.5	1.6	533.4	533	457.0	89	159	628.5	35	24
	500	508.0	775	63.5	1.6	584.2	587	508.0	95	162	686.0	35	24
	600	609.6	915	70.0	1.6	692.2	702	609.5	106	168	813.0	42	24

PLATE FLANGES

SPECIFICATIONS: AS2129
TABLE FLANGES

TYPE: SLIP-ON WELD SOW
BLIND BL

CLASS: TABLE D, E, F & H

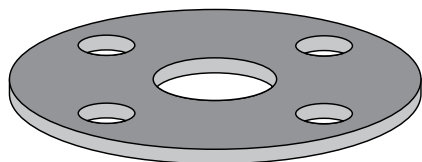

SLIP-ON

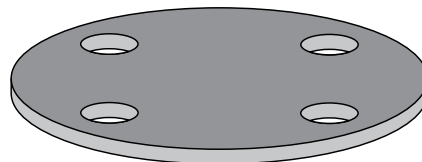

BLIND

GRADE	SIZE N.B. mm	TABLE D		TABLE E		TABLE F		TABLE H	
		SLIP-ON	BLIND	SLIP-ON	BLIND	SLIP-ON	BLIND	SLIP-ON	BLIND
304L	15			★	★	☆	☆	★	☆
	20			★	★	☆	☆	★	☆
	25			★	★	★	☆	★	☆
	32			★	★	★	☆	★	☆
	40	★	★	★	★	★	☆	★	☆
	50	★	★	★	★	★	☆	★	☆
	65	★	★	★	★	★	☆	★	☆
	80	★	★	★	★	★	☆	★	☆
	100	★	★	★	★	☆	★	★	☆
	125	★	★	★	★	☆	☆	☆	☆
	150	★	★	★	★	★	☆	★	☆
	200	★	★	★	★	☆	☆	☆	☆
	250	★	★	★	★	☆	☆	☆	☆
	300	★	★	★	★	☆	☆	☆	☆
316L	15			★	★	★	☆	★	☆
	20			★	★	★	☆	★	☆
	25			★	★	☆	☆	★	☆
	32			★	★	★	☆	★	☆
	40	★	★	★	★	☆	☆	★	☆
	50	★	★	★	★	★	☆	★	☆
	65	★	★	★	★	★	☆	★	☆
	80	★	★	★	★	★	☆	★	☆
	100	★	★	★	★	★	☆	★	☆
	125	★	★	★	★	☆	☆	☆	☆
	150	★	★	★	★	☆	☆	★	☆
	200	★	★	★	★	☆	☆	★	☆
250	★	★	★	★	☆	☆	☆	☆	
300	★	★	★	★	☆	☆	☆	☆	
350	★	★	★	★	☆	☆	☆	☆	
400	★	★	★	★	☆	☆	☆	☆	
450	★	☆	★	★	☆	☆	☆	☆	
500	★	★	★	★	☆	☆	☆	☆	
600	★	★	★	★	☆	☆	☆	☆	

NOTE: Plate Flanges above 300mm are made to manufacture.
Non Standard Flanges are our speciality.

TECHNICAL DATA

PLATE FLANGE DIMENSIONS

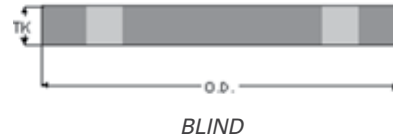
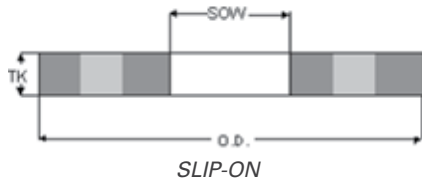

TABLE D

SIZE	SLIP ON BORE	OUTER DIA.	THICKNESS	BOLT CIRCLE DIA.	# OF HOLES	DIA. OF HOLES
mm	SOW	OD	TK	PCD		
15	22.3	95	5	67	4	14
20	27.6	100	5	73	4	14
25	34.5	115	5	83	4	14
32	43.1	120	6	87	4	14
40	49.5	135	6	98	4	14
50	61.9	150	8	114	4	18
65	74.6	165	8	127	4	18
80	90.6	185	10	146	4	18
90	103.3	205	10	165	4	18
100	116	215	10	178	4	18
125	143.7	255	13	210	8	18
150	170.6	280	13	235	8	18
200	221.4	335	13	292	8	18
250	276.3	405	16	356	8	22
300	327.1	455	19	406	12	22
350	359.1	525	22	470	12	26
375	381	550	22	495	12	26
400	410.4	580	22	521	12	26
450	461.7	640	25	584	12	26
500	513	705	29	641	16	26
550	564.3	760	29	699	16	30
600	615.9	825	32	756	16	30
700	717.5	910	38	845	20	30
750	768.3	995	38	927	20	33
800	819.1	1060	38	984	20	36
850	869.9	1090	50	1016	20	36
900	920.7	1175	50	1092	24	36

TABLE E

SIZE	SLIP ON BORE	OUTER DIA.	THICKNESS	BOLT CIRCLE DIA.	# OF HOLES	DIA. OF HOLES
mm	SOW	OD	TK	PCD		
15	22.3	95	6	67	4	14
20	27.6	100	6	73	4	14
25	34.5	115	7	83	4	14
32	43.1	120	8	87	4	14
40	49.5	135	9	98	4	14
50	61.9	150	10	114	4	18
65	74.6	165	10	127	4	18
80	90.6	185	11	146	4	18
90	103.3	205	13	165	8	18
100	116	215	13	178	8	18
125	143.7	255	14	210	8	18
150	170.6	280	17	235	8	22
200	221.4	335	19	292	8	22
250	276.3	405	22	356	12	22
300	327.1	455	25	406	12	26
350	359.1	525	29	470	12	26
375	410.4	550	32	495	12	26
400	410.4	580	32	521	12	26
450	461.7	640	35	584	16	26
500	513	705	38	641	16	26
550	564.3	760	44	699	16	30
600	615.9	825	48	756	16	33
700	717.5	910	54	845	20	33
750	768.3	995	54	927	20	36
800	819.1	1060	54	984	20	36
850	869.9	1090	57	1016	20	36
900	920.7	1175	64	1092	24	36

TECHNICAL DATA

PLATE FLANGE DIMENSIONS

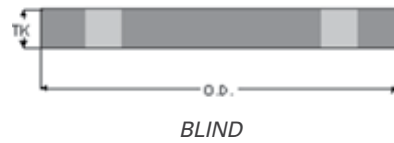
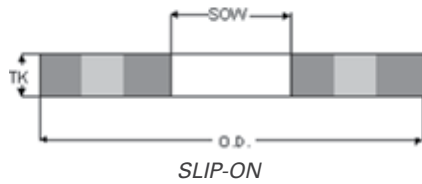

TABLE F

SIZE	SLIP ON BORE	OUTER DIA.	THICKNESS	BOLT CIRCLE DIA.	# OF HOLES	DIA. OF HOLES
mm	SOW	OD	TK	PCD		
15	22.3	95	10	67	4	14
20	27.6	100	10	73	4	14
25	34.5	120	10	87	4	18
32	43.1	135	13	98	4	18
40	49.5	140	13	105	4	18
50	61.9	165	16	127	4	18
65	74.6	185	16	146	8	18
80	90.6	205	16	165	8	18
90	103.3	215	19	178	8	18
100	116	230	19	191	8	18
125	143.7	280	22	235	8	22
150	170.6	305	22	260	12	22
200	221.4	370	25	324	12	22
250	276.3	430	29	381	12	26
300	327.1	490	32	438	16	26
350	359.1	550	35	495	16	30
375	410.4	580	38	521	16	30
400	410.4	610	41	552	20	30
450	461.7	675	44	610	20	33
500	513	735	51	673	24	33
550	564.3	785	54	724	24	33
600	615.9	850	57	781	24	36
700	717.5	935	60	857	24	36
750	768.3	1015	67	940	28	36
800	819.1	1060	68	984	28	36
850	869.9	1090	70	1016	32	36
900	920.7	1185	76	1105	32	39

TABLE H

SIZE	SLIP ON BORE	OUTER DIA.	THICKNESS	BOLT CIRCLE DIA.	# OF HOLES	DIA. OF HOLES
mm	SOW	OD	TK	PCD		
15	22.3	115	13	83	4	18
20	27.6	115	13	83	4	18
25	34.5	120	14	87	4	18
32	43.1	135	17	98	4	18
40	49.5	140	17	105	4	18
50	61.9	165	19	127	4	18
65	74.6	185	19	146	8	18
80	90.6	205	22	165	8	18
90	103.3	215	22	178	8	18
100	116	230	25	191	8	18
125	143.7	280	29	235	8	22
150	170.6	305	29	260	12	22
200	221.4	370	32	324	12	22
250	276.3	430	35	381	12	26
300	327.1	490	41	438	16	26
350	359.1	550	48	495	16	30
375	410.4	580	50	521	16	30
400	410.4	610	54	552	20	30
450	461.7	675	60	610	20	33
500	513	735	67	673	24	33
550	564.3	785	70	724	24	33
600	615.9	850	76	781	24	36

WELDED ROUND TUBE

SPECIFICATIONS:	ASTM A554 ASTM A269 AS1528
LENGTHS:	6 METRES
FINISH:	MILL FINISH W POLISHED 320 GRIT P POLISHED MIDWAY MIRROR M ANNEALED POLISHED 600 GRIT PA FOOD POLISHED 320 GRIT F



SIZE mm		T304					T316				
OD	WT	W	P	M	PA	F	W	P	M	F	PA
6.35	0.7	☆	☆		☆						
6.35	0.9	☆	☆		☆						★
7.94	0.9	☆	☆		☆						
9.53	0.9	☆	★		☆						
9.53	1.2	☆	★		☆		☆	☆			★
9.53	1.6	☆	★		★		☆	★	★		☆
12.7	1.2	☆	★		☆		☆	☆			★
12.7	1.6	☆	★		☆		☆	★	★		★
15.9	1.2	☆	★		☆		☆	☆			☆
15.9	1.6	☆	★		☆		☆	★	★		★
19.05	0.9	☆	★		☆						
19.05	1.2	☆	★		☆		☆	☆	★		☆
19.05	1.6	☆	★		☆		☆	★	★		★
22.2	1.2	☆	☆		☆		☆	☆	★		☆
22.2	1.6	☆	★		☆		☆	★	★		★
25.4	0.9	☆	★		☆		☆	☆	☆		☆
25.4	1.2	☆	★		☆		☆	☆	★		☆
25.4	1.6	☆	★		☆	★	☆	★	★	★	★
28.6	1.2	☆	☆		☆		☆	☆	★		
28.6	1.6	☆	☆		☆		☆	☆	☆		
31.8	1.2	☆	★		☆	★	☆	☆	★		☆
31.8	1.6	☆	★		☆	★	☆	★	★	★	★
31.8	3.0								★		
38.1	1.2	☆	★		☆	★	☆	☆	☆		☆
38.1	1.6	☆	★		★	★	★	★	★	★	★
38.1	3.0			☆					★		
41.28	1.6								★		
44.4	1.2	☆	☆		☆						
44.4	1.6	☆	★	★	☆	☆	☆	☆	★		☆
50.8	1.2	☆	★		☆	★	☆	☆			☆
50.8	1.6	☆	★		★	★	★	★	★	★	★
50.8	2.0	☆	☆					★	☆		
50.8	3.0			★					★		
57.15	1.6							★			
63.5	1.2	☆	☆		★						
63.5	1.6	☆	★		☆	★	☆	★	★	★	☆
63.5	2.0							★			
63.5	3.0								★		
76.2	1.6	☆	★		★	★	★	★	★	★	☆
76.2	2.0	☆	☆					★	☆		
88.9	1.6	☆	★		☆		☆	★			☆
101.6	1.6	☆	★		☆	★	★	★		★	☆
101.6	2.0										
127	1.6	☆	★				★	★			☆
152.4	1.6	★	★			★	★	★		★	
152.4	2.0		☆			☆		★		★	
203.2	2.0	★	★			★	★	★		★	
254	2.0	★				★	★			★	

ARCHITECTURAL TUBE

SPECIFICATIONS:	ASTM A554	
LENGTH:	6 METRES	
FINISH:	POLISHED MIRROR	M
	POLISHED 400 grit P	

SLOTTED HAND RAIL

SIZE mm	T304	T316	
		P	M
50.8 x 1.5 - Single Slot	☆	★	★
63.5 x 1.5 - Single Slot	☆	★	★
76.2 x 1.5 - Single Slot	☆	★	★
50.8 x 1.5 - Double Slot	☆	★	★
50.8 x 1.5 - 90 Degree Slot	☆	★	★

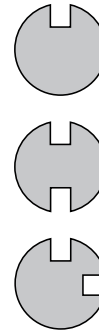

OVAL / D TUBE

SIZE mm	T304	T316
	M	M
32 x 63 x 1.5mm - 'D'	☆	☆
23 x 38 x 1.5mm - Oval	☆	★
26 x 48 x 1.5mm - Oval	☆	★
38 x 62 x 1.5mm - Oval	☆	★
42 x 75 x 1.5mm - Oval	☆	★

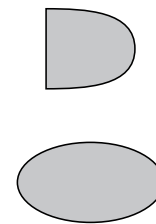

TRIANGULAR TUBE

SIZE mm	T304	T316
	M	M
37 x 25 x 1.5mm	☆	★

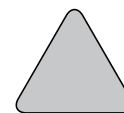

RIGI TUBE - DEC N9 PATTERN

SIZE mm	T304	T316
	P	P
31.8 x 1.2 - Reverse Pattern	☆	☆
31.8 x 1.5 - Standard Pattern	☆	☆

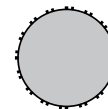

WELDED SQUARE & RECTANGLE TUBE

SPECIFICATIONS:	ASTM A554
LENGTH:	6 METRES
FINISH:	POLISHED 180 HAIRLINE SBP POLISHED 400 grit 400

SQUARE TUBE

SIZE mm	T304	T316	
	SBP	SBP	400
12.7 x 12.7 x .9	☆		
12.7 x 12.7 x 1.2	★	☆	
19 x 19 x 1.2	★	☆	
19 x 19 x 1.6	★	★	★
22.2 x 22.2 x 1.2	★	☆	
22.2 x 22.2 x 1.6	☆	☆	
25.4 x 25.4 x 1.2	★	☆	
25.4 x 25.4 x 1.6	★	★	★
31.8 x 31.8 x 1.2	★	☆	
31.8 x 31.8 x 1.6	★	★	★
38.1 x 38.1 x 1.2	★	☆	
38.1 x 38.1 x 1.6	★	★	★
50.8 x 50.8 x 1.2	★	☆	
50.8 x 50.8 x 1.6	★	★	★

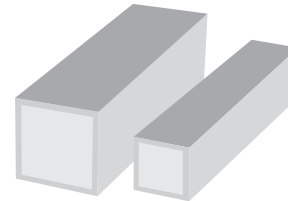

SIZE mm	T304	T316	
	SBP	SBP	400
25 x 25 x 2	★	☆	☆
25 x 25 x 3	★	☆	☆
32 x 32 x 2	★	☆	☆
32 x 32 x 3	★	☆	☆
38 x 38 x 2	★	☆	
38 x 38 x 3	★	★	★
50 x 50 x 2	★	☆	
50 x 50 x 3	★	★	★
60 x 60 x 3	★	☆	☆
80 x 80 x 2	★	☆	
80 x 80 x 3	★	★	☆
80 x 80 x 5	★	★	☆
100 x 100 x 3	★	★	☆
100 x 100 x 5	★	★	☆
150 x 150 x 5	★	★	☆
150 x 150 x 3	★	☆	☆

RECTANGLE TUBE

SIZE mm	T304	T316	
	SBP	SBP	400
38.1 x 25.4 x 1.6	☆	☆	
50.8 x 25.4 x 1.2	★	☆	
50.8 x 25.4 x 1.6	★	★	★
80 x 40 x 1.6	★	☆	☆

SIZE mm	T304	T316	
	SBP	SBP	400
50 x 10 x 2	★		★
50 x 25 x 3	★	★	★
60 x 40 x 3	★	★	
80 x 40 x 3	★	★	☆
100 x 50 x 2	★	☆	
100 x 50 x 3	★	★	☆
100 x 50 x 5	★	★	☆
150 x 50 x 6	☆	☆	★
150 x 75 x 5	★	☆	☆
150 x 100 x 5	★	★	☆
150 x 100 x 6	☆	☆	★
200 x 100 x 5	★	☆	☆
200 x 100 x 6	☆	☆	☆

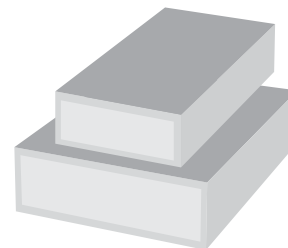

TUBE FITTINGS

SPECIFICATIONS: AUSTRALIAN STANDARD 1528
PART 3 - 1975
BENDS CLR 1.50

FINISH: BENDS UNPOLISHED & POLISHED
OTHERS POLISHED



SIZE		THICK	90° BEND		45° BEND		180° BEND	EQUAL TEE		Y PIECE	CAP	CROSS
Inch	mm	mm	304	316	304	316	316	304	316	316	316	316
1/2	12.7	1.6		★		★			★			
5/8	15.88	1.6		★								
3/4	19.05	1.6	★	★		★	☆		★		★	
1	25.4	1.6	★	★	★	★	★	★	★	☆	★	☆
1 1/4	31.8	1.6	★	★		★	★	★	★	☆	★	☆
1 1/2	38.1	1.6	★	★	★	★	★	★	★	☆	★	★
1 3/4	44.45	1.6		★								
2	50.8	1.6	★	★	★	★	★	★	★	★	★	★
2 1/2	63.5	1.6	★	★	★	★	★	★	★	☆	★	☆
3	76.2	1.6	★	★	★	★	★	★	★	★	★	★
3 1/2	88.9	1.6		★								
4	101.6	1.6	★	★	★	★	★	★	★	☆	★	☆
5	127	1.6	★	★	☆	★	☆	★	★	☆	☆	☆
6	152.4	1.6	★	★	☆	★	☆	★	★	☆	★	☆
8	203.2	1.6	☆	☆	☆	☆	☆	☆	☆		★	
10	254	1.6	☆	☆	☆	☆	☆		☆			
12	305	1.6	☆	☆	☆	☆	☆		☆			
4	101.6	2		★					☆			
5	127	2	★	★					☆			
6	152.4	2	★	★	★	★			☆			
8	203.2	2	★	★					☆			
10	254	2	★	★					☆			
12	305	2	★	★					☆			

REDUCING TUBE FITTINGS

SPECIFICATIONS: AUSTRALIAN STANDARD 1528
PART 3 - 1975

FINISH: POLISHED

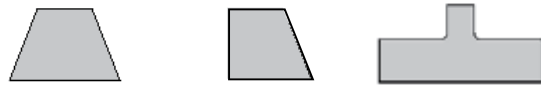

OD		TK	CONCENTRIC REDUCER	ECCENTRIC REDUCER	REDUCING TEE
mm	Inch	mm			
19.1 x 12.7	3/4 x 1/2	1.6	★	☆	☆
25.4 x 12.7	1 x 1/2	1.6	★	☆	★
25.4 x 19.1	1 x 3/4	1.6	★	★	★
31.8 x 19.1	1 1/4 x 3/4	1.6	★	☆	☆
31.8 x 25.4	1 1/4 x 1	1.6	★	☆	☆
38.1 x 12.7	1 3/4 x 1/2	1.6	★	☆	☆
38.1 x 19.1	1 1/2 x 3/4	1.6	★	☆	☆
38.1 x 25.4	1 1/2 x 1	1.6	★	★	★
38.1 x 31.8	1 1/2 x 1 1/4	1.6	★	★	☆
50.8 x 12.7	2 x 1/2	1.6	★	☆	☆
50.8 x 19.1	2 x 3/4	1.6	★	★	★
50.8 x 25.4	2 x 1	1.6	★	★	★
50.8 x 31.8	2 x 1 1/4	1.6	★	★	★
50.8 x 38.1	2 x 1 1/2	1.6	★	★	★
63.5 x 19.1	2 1/2 x 3/4	1.6	☆	☆	☆
63.5 x 25.4	2 1/2 x 1	1.6	★	★	★
63.5 x 31.8	2 1/2 x 1 1/4	1.6	★	★	☆
63.5 x 38.1	2 1/2 x 1 1/2	1.6	★	★	☆
63.5 x 50.8	2 1/2 x 2	1.6	★	★	★
76.2 x 19.1	3 x 3/4	1.6	☆	☆	☆
76.2 x 25.4	3 x 1	1.6	★	★	★
76.2 x 31.8	3 x 1 1/4	1.6	★	☆	☆
76.2 x 38.1	3 x 1 1/2	1.6	★	★	☆
76.2 x 50.8	3 x 2	1.6	★	★	★
76.2 x 63.5	3 x 2 1/2	1.6	★	★	★
101.6 x 25.4	4 x 1	1.6	★	☆	☆
101.6x38.1	4 x 1 1/2	1.6	★	☆	☆
101.6 x 50.8	4 x 2	1.6	★	★	★
101.6 x 63.5	4 x 2 1/2	1.6	★	★	★
101.6 x 76.2	4 x 3	1.6	★	★	★
127 x 50.8	5 x 2	1.6	★	☆	☆
127. x 63.5	5 x 2 1/2	1.6	☆	★	☆
127 x 76.2	5 x 3	1.6	★	★	☆
127 x 101.6	5 x 4	1.6	★	★	☆
152.4 x 25.4	6 x 1	1.6	☆	☆	☆
152.4 x 50.8	6 x 2	1.6	★	★	☆
152.4 x 63.5	6 x 2 1/2	1.6	★	★	☆
152.4 x 76.2	6 x 3	1.6	★	★	☆
152.4 x 101.6	6 x 4	1.6	★	★	☆
152.4 x 127	6 x 5	1.6	★	★	☆
203.2 x 101.6	8 x 4	1.6	★	★	☆
203.2 x 127	8 x 5	1.6	★	☆	☆
203.2 x 152.4	8 x 6	1.6	★	☆	☆

TECHNICAL DATA

TUBE FITTING DIMENSIONS

CENTRE-TO-FACE DIMENSIONS OF 45°, 90° & 180° TUBE BENDS

NOMINAL SIZE	CENTRE-TO-FACE DIMENSIONS			
	A	B	C	WALL
mm	mm	mm	mm	mm
12.7	19.1	49.1	30	1.6
19.1	28.6	58.6	30	1.6
25.4	38.1	68.1	30	1.6 / 2
31.8	47.7	77.7	30	1.6 / 2
38.1	57	87	30	1.6 / 2
50.8	76.2	106.2	30	1.6 / 2
63.5	95	125	30	1.6 / 2
76.2	114.2	144.2	30	1.6 / 2
101.6	152.4	182.4	30	1.6 / 2
127	190.5	230.5	40	1.6 / 2
152.4	228.5	268.5	40	1.6 / 2
203.2	304.8	334.8	40	1.6 / 2

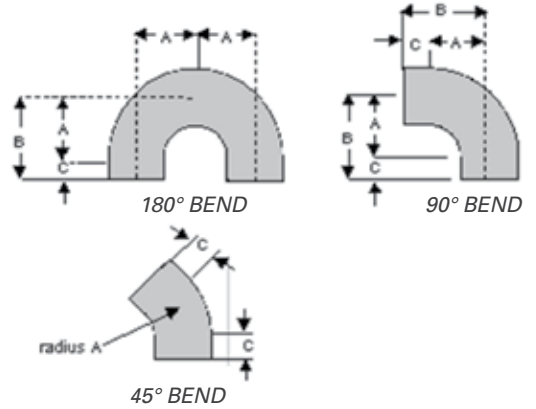

NOTE: C = The Straight End Extension

CENTRE-TO-FACE DIMENSIONS OF EQUAL TEES

NOMINAL SIZE	CENTRE-TO-FACE DIMENSIONS	
	A	B
mm	mm	mm
12.7	55.4	98.2
19.1	68.1	117.2
25.4	80.8	136.2
31.8	93.6	155.4
38.1	106	174
50.8	130.6	212.4
63.5	156.8	250
76.2	182.3	288.4
101.6	233.2	364.8
127	294	461
152.4	344.7	537

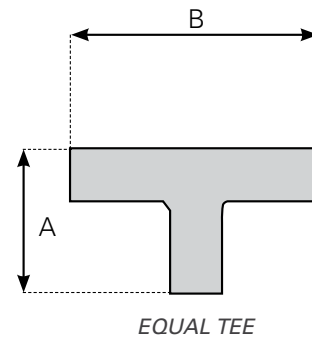

DIMENSIONS OF WELDED TYPE 'Y' PIECE

NOMINAL SIZE	CENTRE-TO-FACE DIMENSIONS	
	A	B
mm	mm	mm
25.4	88	72
31.8	110	90
38.1	132	108
50.8	176	143
63.5	220	179
76.2	264	215
101.6	352	287
127	359	440
152.4	430	529

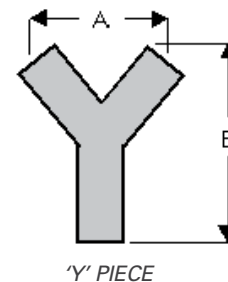

TECHNICAL DATA

TUBE FITTING DIMENSIONS

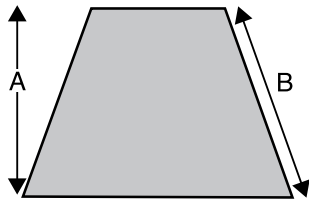

CONCENTRIC REDUCER

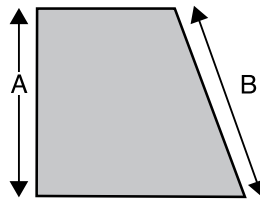

ECCENTRIC REDUCER

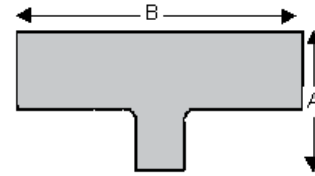

REDUCING TEE

SIZE		TK	CONCENTRIC REDUCER		ECCENTRIC REDUCER		REDUCING TEE	
mm	Inch		A	B	A	B	A	B
19.1 X 12.7	3/4 x 1/2	1.6	20	20	20	22		
25.4 X 12.7	1 x 1/2	1.6	25	25	25	27		
25.4 X 19.1	1 x 3/4	1.6	25	25				
31.8 X 19.1	1 1/4 x 3/4	1.6	32	32				
31.8 X 25.4	1 1/4 x 1	1.6	32	32	32	34		
38.1 X 12.7	1 1/2 x 1/2	1.6	38	40	38	40		
38.1 X 19.1	1 1/2 x 3/4	1.6	38	38	38	40		
38.1 X 25.4	1 1/2 x 1	1.6	38	38	38	40	70	89
38.1 X 31.8	1 1/2 x 1 1/4	1.6	38	38	38	40		
50.8 X 12.7	2 x 1/2	1.6	51	54				
50.8 X 19.1	2 x 3/4	1.6	51	54	50	52		
50.8 X 25.4	2 x 1	1.6	51	52	50	53	83	90
50.8 X 31.8	2 x 1 1/4	1.6	51	52	50	53	93	120
50.8 X 38.1	2 x 1 1/2	1.6	51	52	50	53	100	131
63.5 X 19.1	2 1/2 x 3/4	1.6	63	65				
63.5 X 25.4	2 1/2 x 1	1.6	63	65	63	65		
63.5 X 31.8	2 1/2 x 1 1/4	1.6	63	65	63	65		
63.5 X 38.1	2 1/2 x 1 1/2	1.6	63	63	63	65	114	133
63.5 X 50.8	2 1/2 x 2	1.6	63	63	63	65	130	178
76.2 x 19.1	3 x 3/4	1.6	76	80			107	110
76.2 X 25.4	3 x 1	1.6	76	80	76	80	111	100
76.2 x 31.8	3 x 1 1/4	1.6	76	80				
76.2 X 38.1	3 x 1 1/2	1.6	76	76	76	80	125	133
76.2 X 50.8	3 x 2	1.6	76	76	76	80	140	178
76.2 X 63.5	3 x 2 1/2	1.6	76	76	76	81	159	229
101.6 X 25.4	4 x 1	1.6	102	107	101	110		
101.6 X 38.1	4 x 1 1/2	1.6	102	107	101	110	154	133
101.6 X 50.8	4 x 2	1.6	102	103	101	110	171	178
101.6 X 63.5	4 x 2 1/2	1.6	102	103	101	110	188	229
101.6 X 76.2	4 x 3	1.6	102	103	101	110	189	254
127 X 50.8	5 x 2	1.6	127	132	127	138		
127. X 63.5	5 x 2 1/2	1.6	127	132	127	138		
127 X 76.2	5 x 3	1.6	127	127	127	140	218	254
127 X 101.6	5 x 4	1.6	127	127	127	140	218	292
152.4 X 38.1	6 x 1 1/2	1.6	153	165				
152.4 X 50.8	6 x 2	1.6	153	161	152	162		
152.4 X 63.5	6 x 2 1/2	1.6	153	158	152	165		
152.4 X 76.2	6 x 3	1.6	153	158	152	162	244	254
152.4 X 101.6	6 x 4	1.6	153	153	152	162	252	300
152.4 X 127	6 x 5	1.6	153	153	152	162	385	380
203.2 X 101.6	8 x 4	1.6	205	208	205	215	304	300
203.2 X 127	8 x 5	1.6	205	212	205	215	330	380
203.2 X 152.4	8 x 6	1.6	205	205	205	215	348	440

HYGIENIC FITTINGS

SPECIFICATIONS: BSM/RJT Fittings to AS1528, Part 4 - 1976

BSM/RJT FITTINGS



SIZE mm	ROUND SLOTTED NUT	HEX. NUT	PLAIN LINER	MALE PART	O-RING EPDM	O-RING TEFLON	O-RING VITON	CIP SEAL	BLANK CAP	BLANK NUT	ALUM. SPANNER
25.4	★	★	★	★	★	☆	★	★	★	☆	★
38.1	★	★	★	★	★	☆	★	★	★	☆	★
50.8	★	★	★	★	★	☆	★	★	★	☆	★
63.5	★	★	★	★	★	☆	★	★	★	☆	★
76.2	★	★	★	★	★	☆	★	★	★	☆	★
101.6	★	★	★	★	★	☆	★	★	★	☆	★
127.0	☆	★	★	★	★	☆	★	★	★	☆	★
152.4	☆	★	★	★	★	☆	★	★	★	☆	★

HYGIENIC FLAT FACE FITTINGS



SIZE mm	HEX. NUT	FLAT FACE LINER	MALE PART LIP REMOVED	SEAL EPDM	SEAL TEFLON
12.7	★	★	★	★	☆
19.05	★	★	★	★	☆
25.4	★	★	★	★	☆
38.1	★	★	★	★	☆
50.8	★	★	★	★	☆
63.5	★	★	★	★	☆
76.2	★	★	★	★	☆
101.6	★	★	★	★	☆
127.0	☆	☆	☆	☆	☆
152.4	★	★	★	★	☆

TUBE CLAMPS



SIZE mm	PLAIN	BOSSSED	LONGTANG
19.05	★	★	
25.4	★	★	★
31.8	★	★	★
38.1	★	★	★
50.8	★	★	★
63.5	★	★	★
76.2	★	★	★
101.6	★	★	★
127.0	☆	☆	☆
152.4	★	★	★

SPECIFICATIONS: Triclover Fittings to AS1528, Part 2 - 1976

TRICLOVER FITTINGS



SIZE mm	CLAMP BODY	FERRULE LONG	BLANK CAP	SEAL EPDM	SEAL BUNA	SEAL TEFLON	SEAL VITON
19.05	★	★	★	★	☆	☆	☆
25.4	★	★	★	★	☆	☆	★
38.1	★	★	★	★	☆	☆	★
50.8	★	★	★	★	☆	☆	★
63.5	★	★	★	★	☆	☆	★
76.2	★	★	★	★	☆	☆	★
101.6	★	★	★	★	☆	☆	★
127.0	☆	☆	☆	☆	☆	☆	☆
152.4	★	★	★	★	☆	☆	★

TECHNICAL DATA

HYGIENIC FITTINGS

HEXAGONAL NUT

SIZE mm	A	B	C
25.4	42.266 x 8TPI WHIT	33.45	22.2
38.1	54.966 x 8TPI WHIT	46.0	22.2
50.8	67.920 x 6TPI WHIT	58.67	22.2
63.5	80.620 x 6TPI WHIT	71.4	22.2
76.2	93.320 x 6TPI WHIT	84.1	22.2
101.6	118.720 x 6TPI WHIT	109.7	22.2
127.0	144.000 x 6TPI WHIT	134.9	22.2
152.4	169.520 x 6TPI WHIT	163.0	22.2

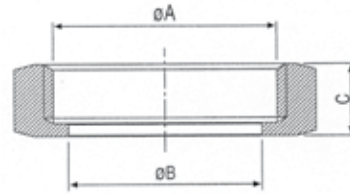

PLAIN LINER

SIZE mm	A	B	C	D	E
25.4	22.2	25.65	32.5	41.3	19.5
38.1	34.9	38.35	45.2	54.0	19.5
50.8	47.6	51.05	57.9	66.7	19.5
63.5	60.3	63.75	70.6	79.4	19.5
76.2	73.0	76.45	83.3	92.1	19.5
101.6	97.6	101.85	108.7	117.5	19.5
127.0	123.8	127.00	134.0	142.9	23.5
152.4	148.0	152.50	161.8	169.1	23.5

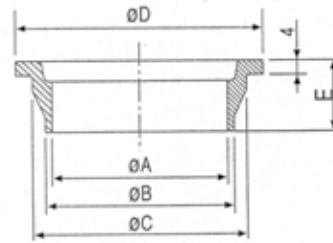

MALE PART

SIZE mm	A	B	C	D
25.4	22.2	25.65	45.72 x 8TPI WHIT	27
38.1	34.9	38.35	58.42 x 8TPI WHIT	27
50.8	47.6	51.05	72.72 x 6TPI WHIT	27
63.5	60.3	63.75	85.42 x 6TPI WHIT	27
76.2	73.0	76.45	98.12 x 6TPI WHIT	27
101.6	97.6	101.85	123.52 x 6TPI WHIT	27
127.0	123.8	127.00	148.30 x 6TPI WHIT	24
152.4	148.0	152.50	174.32 x 6TPI WHIT	24

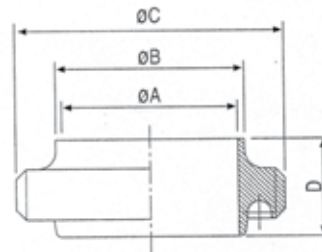

O-RING (EPDM,TEFLON, VITON)

SIZE mm	A	B	C
25.4	33.3	6.6	3.2
38.1	46.0	6.6	3.2
50.8	58.7	6.6	3.2
63.5	71.4	6.6	3.2
76.2	84.1	6.6	3.2
101.6	109.5	6.6	3.2
127.0	134.9	6.6	3.2
152.4	162.6	6.6	3.2

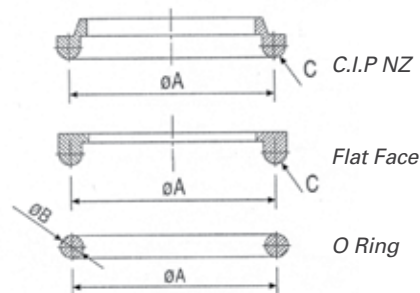

TECHNICAL DATA

HYGIENIC FITTINGS

ROUND SLOTTED NUT

SIZE mm	A	B	C	SLOTS
25.4	42.266 x 8TPI WHIT	58.5	33.45	4
38.1	54.966 x 8TPI WHIT	74.0	46.0	4
50.8	67.920 x 6TPI WHIT	85.5	58.67	6
63.5	80.620 x 6TPI WHIT	98.5	71.4	6
76.2	93.320 x 6TPI WHIT	111.6	84.1	8
101.6	119.000 x 6TPI WHIT	138.0	109.7	8
152.4	169.520 x 6TPI WHIT	197.0	163.0	10

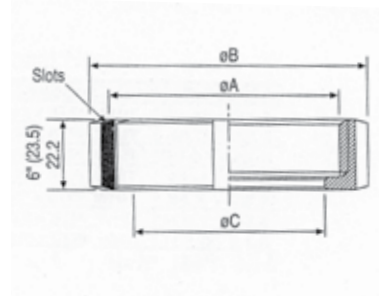

HEXAGONAL BLANK NUT

SIZE mm	A	B	C
25.4	42.266 x 8TPI WHIT	22.2	4
38.1	54.966 x 8TPI WHIT	22.2	4
50.8	67.920 x 6TPI WHIT	22.2	4
63.5	80.620 x 6TPI WHIT	22.2	4
76.2	93.320 x 6TPI WHIT	22.2	4
101.6	118.720 x 6TPI WHIT	22.2	4

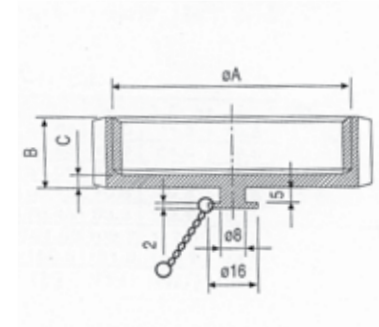

FLAT FACE LINER

SIZE mm	A	B	C	D
25.4	22.2	41.3	25.8	32.5
38.1	34.9	54.0	38.5	45.2
50.8	47.6	66.7	51.2	57.9
63.5	60.3	79.4	63.9	70.6
76.2	73.0	92.1	76.6	83.3
101.6	97.6	117.5	102.2	108.7

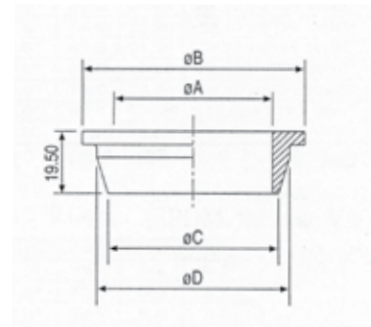

MALE PART (LIP REMOVED)

SIZE mm	A	B	C
25.4	22.2	25.65	45.72 x 8T WHIT
38.1	34.9	38.35	58.42 x 8T WHIT
50.8	47.6	51.05	72.72 x 6T WHIT
63.5	60.3	63.75	85.42 x 6T WHIT
76.2	73.0	76.45	98.12 x 6T WHIT
101.6	97.6	101.85	123.52 x 6T WHIT

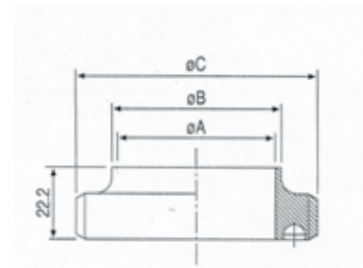

TECHNICAL DATA

TRICLOVER FITTINGS

CLAMP HEAVY DUTY

SIZE mm	A	B
12.7 - 19.05	20	28
38.1	43.6	53.6
50.8	57	67
63.5	70.6	80.6
76.2	84	94
101.6	112	122
152.4	155	170

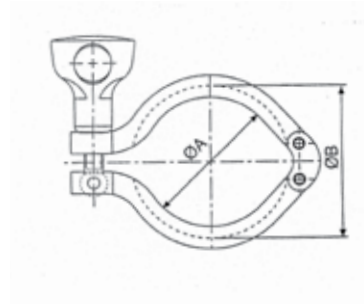

FERRULE LONG

SIZE mm	A	B	C	D
12.7	9.45	12.75	25.2	28.6
19.05	15.75	19.05	25.2	28.6
25.4	22.2	25.4	50.5	28.6
38.1	34.9	38.1	50.5	28.6
50.8	47.6	50.8	64.0	28.6
63.5	60.3	63.5	77.5	28.6
76.2	73.0	76.2	91.0	28.6
101.6	97.6	101.6	119.0	28.6
152.4	146.8	152.5	166.8	28.6

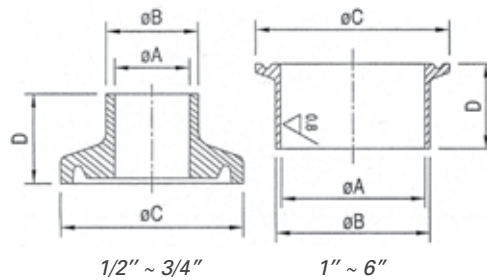

FLANGE SEAL

SIZE mm	A	B
25.4	22.8	52.7
38.1	35.8	52.7
50.8	48.8	66.2
63.5	60.5	79.7
76.2	73.1	93.2
101.6	97.8	121.2



BLANK CAP

SIZE mm	A	B
12.7 - 19.05	25.2	5.0
25.4 - 38.1"	50.5	6.3
50.8	64.0	6.3
63.5	77.5	6.3
76.2	91.0	6.3
101.6	119.0	7.9
152.4	166.7	11.1

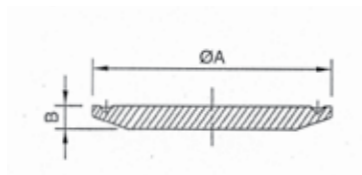

STANDARD SEAL

SIZE mm	A	B
12.7	21.8	9.9
19.05	21.8	16.3
25.4	50.0	22.7
38.1	50.0	35.9
50.8	63.5	48.6
63.5	76.2	61.3
76.2	88.9	74.0
101.6	118.0	98.6

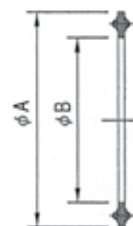

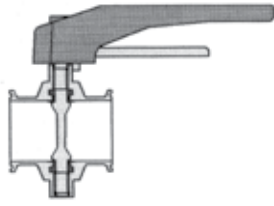
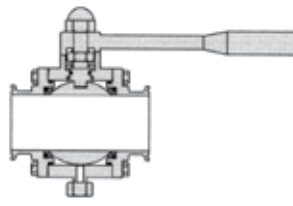
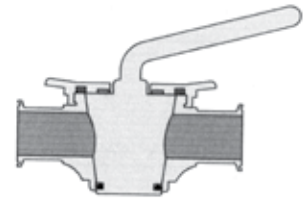
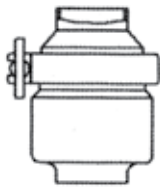
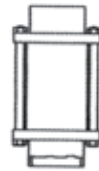
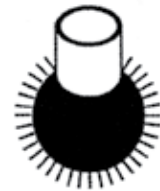
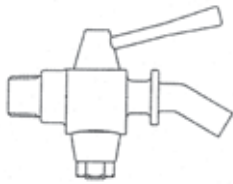
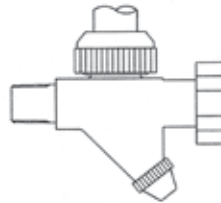
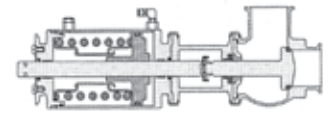
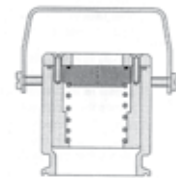
*BUTTERFLY VALVES**BALL VALVES**PLUG VALVES**CHECK VALVES**SIGHT GLASSES**SPRAY BALLS**SAMPLING VALVES**LEVEL GAUGES**SHUT OFF & DIVERT VALVES**FILTERS & STRAINERS**PRESSURE RELIEF VALVES**TANK VENTS*

NOTE: A comprehensive hygienic valves and equipment catalogue is available upon request.

PLATE FLANGES

SPECIFICATIONS:	AS2129 TABLE FLANGES	
TYPE:	SLIP-ON WELD BLIND	SOW BL
CLASS:	TABLE D, E, F & H	

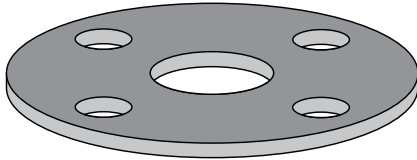

SLIP-ON

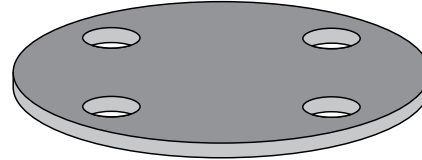

BLIND

GRADE	SIZE I.D mm	TABLE D		TABLE E		TABLE F		TABLE H	
		SLIP-ON	BLIND	SLIP-ON	BLIND	SLIP-ON	BLIND	SLIP-ON	BLIND
304L	12.7			★	★	☆	☆	☆	☆
	19.05			★	★	☆	☆	☆	☆
	25.4			★	★	☆	☆	☆	☆
	31.8			★	★	☆	☆	☆	☆
	38.1	★	★	★	★	☆	☆	☆	☆
	50.8	★	★	★	★	☆	☆	☆	☆
	63.5	★	★	★	★	☆	☆	☆	☆
	76.2	★	★	★	★	☆	☆	☆	☆
	101.6	★	★	★	★	★	★	☆	☆
	127	★	★	★	★	☆	☆	☆	☆
	152.4	★	★	★	★	☆	☆	☆	☆
	203.2	★	★	★	★	☆	☆	☆	☆
	254	★	★	★	★	☆	☆	☆	☆
	304.8	★	★	★	★	☆	☆	☆	☆
	356	★	☆	★	☆	☆	☆	☆	☆
	406.4	★	☆	★	★	☆	☆	☆	☆
457.2	☆	☆	☆	★	☆	☆	☆	☆	
508	☆		☆	☆	☆	☆	☆	☆	
609.6	☆	☆	☆	☆	☆	☆	☆	☆	
316L	12.7			★	★	☆	☆	☆	☆
	19.05			★	★	☆	☆	☆	☆
	25.4			★	★	☆	☆	★	☆
	31.8			★	★	☆	☆	☆	☆
	38.1	★	★	★	★	☆	☆	☆	☆
	50.8	★	★	★	★	★	☆	☆	☆
	63.5	★	★	★	★	☆	☆	☆	☆
	76.2	★	★	★	★	☆	☆	☆	☆
	101.6	★	★	★	★	★	☆	☆	☆
	127	★	★	★	★	☆	☆	☆	☆
	152.4	★	★	★	★	☆	☆	☆	☆
	203.2	★	★	★	★	☆	☆	☆	☆
	254	★	★	★	★	☆	☆	☆	☆
	304.8	★	★	★	★	☆	☆	☆	☆
	356	★	★	★	★	☆	☆	☆	☆
	406.4	★	★	★	★	☆	☆	☆	☆
457.2	★	☆	★	☆	☆	☆	☆	☆	
508	★	★	★	★	☆	☆	☆	☆	
609.6	★	☆	★	☆	☆	☆	☆	☆	

TECHNICAL DATA

PLATE FLANGE DIMENSIONS

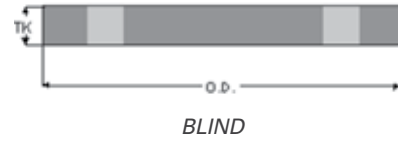
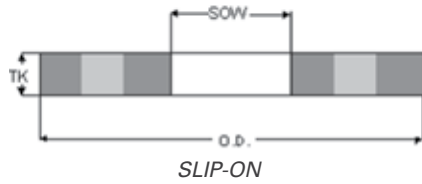

TABLE D

SIZE	SLIP ON BORE	OUTER DIA.	THICKNESS	BOLT CIRCLE DIA.	# OF HOLES	DIA. OF HOLES
mm	SOW	OD	TK	PCD		
12.7	13.7	95	5	67	4	14
19.05	20.1	100	5	73	4	14
25.4	26.4	115	5	83	4	14
31.8	32.8	120	6	87	4	14
38.1	39.3	135	6	98	4	14
50.8	52	150	8	114	4	18
63.5	64.5	165	8	127	4	18
76.2	77.5	185	10	146	4	18
88.9	90.4	205	10	165	4	18
101.6	103	215	10	178	4	18
127	128.5	255	13	210	8	18
152.4	154	280	13	235	8	18
203.2	204.5	335	13	292	8	18
254	256	405	16	356	8	22
304.8	306.5	455	19	406	12	22
355.6	358	525	22	470	12	26
381	384	550	22	495	12	26
406.4	409	580	22	521	12	26
457.2	460	640	25	584	12	26
508	510.5	705	29	641	16	26
558.8	561	760	29	699	16	30
609.6	612	825	32	756	16	30
711.2	714	910	38	845	20	30
762	764.5	995	38	927	20	33
812.8	815.5	1060	38	984	20	36
863.6	866	1090	50	1016	20	36
914.4	917.5	1175	50	1092	24	36

TABLE E

SIZE	SLIP ON BORE	OUTER DIA.	THICKNESS	BOLT CIRCLE DIA.	# OF HOLES	DIA. OF HOLES
mm	SOW	OD	TK	PCD		
12.7	13.7	95	6	67	4	14
19.05	20.1	100	6	73	4	14
25.4	26.4	115	7	83	4	14
31.8	32.8	120	8	87	4	14
38.1	39.3	135	9	98	4	14
50.8	52	150	10	114	4	18
63.5	64.5	165	10	127	4	18
76.2	77.5	185	11	146	4	18
88.9	90.4	205	13	165	8	18
101.6	103	215	13	178	8	18
127	128.5	255	14	210	8	18
152.4	154	280	17	235	8	22
203.2	204.5	335	19	292	8	22
254	256	405	22	356	12	22
304.8	306.5	455	25	406	12	26
355.6	358	525	29	470	12	26
381	384	550	32	495	12	26
406.4	409	580	32	521	12	26
457.2	460	640	35	584	16	26
508	510.5	705	38	641	16	26
558.8	561	760	44	699	16	30
609.6	612	825	48	756	16	33
711.2	714	910	54	845	20	33
762	764.5	995	54	927	20	36
812.8	815.5	1060	54	984	20	36
863.6	866	1090	57	1016	20	36
914.4	917.5	1175	64	1092	24	36

SEAMLESS TUBE

SPECIFICATIONS:	ASTM A269 ASTM A213 (ON REQUEST)
LENGTHS:	FIXED 6 METRES
FINISH:	ANNEALED & PICKLED BRIGHT ANNEALED



SIZE mm		TP304	TP316
OD	WT		
3.18	0.7	☆	★
4.76	0.7	☆	★
6.35	0.9	☆	★
6.35	1.2	☆	★
6.35	1.6	☆	★
7.94	0.9	☆	★
7.94	1.2	☆	★
7.94	1.6	☆	★
9.53	0.9	☆	★
9.53	1.2	☆	★
9.53	1.6	☆	★
12.7	0.9	☆	★
12.7	1.2	☆	★
12.7	1.6	☆	★
15.88	1.2	☆	★
15.88	1.6	☆	★
19.05	1.2	☆	★
19.05	1.6	☆	★
19.05	2.0	☆	★
25.4	1.2	☆	★
25.4	1.6	☆	★
25.4	2	☆	★
31.8	1.6	☆	★
31.8	2	☆	☆
38.1	1.6	☆	★
38.1	2	☆	★
38.1	3	☆	★
50.8	1.6	☆	★
50.8	2	☆	★
50.8	3	☆	★

SEAMLESS/WELDED TUBE

TECHNICAL DATA

APPROXIMATE MASS & THEORETICAL BURSTING PRESSURE FOR SEAMLESS & WELDED TUBE (WELDED REFER NOTES)

WT	mm SWG	0.45	0.51	0.61	0.71	0.91	1.22	1.63	2.03	2.64	3.25
		26	25	23	22	20	18	16	14	12	10
OD mm	Inch										
3.18	1/8	0.030 <i>145.8</i>	0.034 <i>165.2</i>	0.039 <i>197.6</i>	0.043 <i>230.0</i>	0.051 <i>294.7</i>					
4.76	3/16	0.048 <i>97.4</i>	0.053 <i>440.4</i>	0.062 <i>132.0</i>	0.071 <i>153.6</i>	0.086 <i>196.9</i>					
6.35	1/4	0.065 <i>73.0</i>	0.073 <i>82.7</i>	0.086 <i>98.9</i>	0.099 <i>115.2</i>	0.122 <i>146.6</i>	197.9	264.4			
7.94	5/16	0.083 <i>58.4</i>	0.093 <i>66.2</i>	0.110 <i>79.1</i>	0.127 <i>92.1</i>	0.158 <i>118.0</i>	0.202 <i>158.3</i>	0.254 <i>211.4</i>			
9.53	3/8	0.101 <i>48.6</i>	0.113 <i>55.1</i>	0.134 <i>65.9</i>	0.154 <i>76.7</i>	0.193 <i>98.4</i>	0.250 <i>131.9</i>	0.358 <i>176.2</i>			
12.70	1/2	0.136 <i>36.5</i>	0.153 <i>41.4</i>	0.182 <i>49.5</i>	0.210 <i>57.6</i>	0.265 <i>73.8</i>	0.345 <i>98.9</i>	0.445 <i>132.2</i>	0.534 <i>164.6</i>		
15.88	5/8		0.193 <i>33.1</i>	0.230 <i>39.6</i>	0.266 <i>46.1</i>	0.336 <i>59.0</i>	0.441 <i>79.1</i>	0.573 <i>105.7</i>	0.693 <i>131.7</i>		
19.05	3/4		0.233 <i>27.6</i>	0.277 <i>33.0</i>	0.321 <i>38.4</i>	0.407 <i>49.2</i>	0.536 <i>66.0</i>	0.700 <i>88.1</i>	0.852 <i>109.8</i>	1.068 <i>142.7</i>	1.266 <i>175.7</i>
22.23	7/8		0.273 <i>23.6</i>	0.325 <i>28.3</i>	0.377 <i>32.9</i>	0.478 <i>42.2</i>	0.632 <i>56.5</i>	0.828 <i>75.5</i>	1.011 <i>94.1</i>	1.275 <i>122.3</i>	1.521 <i>150.6</i>
25.40	1		0.313 <i>20.7</i>	0.373 <i>24.7</i>	0.432 <i>28.8</i>	0.550 <i>36.9</i>	0.727 <i>49.5</i>	0.955 <i>66.1</i>	1.170 <i>82.3</i>	1.482 <i>107.1</i>	1.775 <i>131.8</i>
28.58	1 1/8				0.488 <i>25.6</i>	0.621 <i>32.8</i>	0.823 <i>44.0</i>	1.083 <i>58.7</i>	1.329 <i>73.2</i>	1.689 <i>95.1</i>	2.030 <i>117.1</i>
31.75	1 1/4				0.543 <i>23.0</i>	0.692 <i>29.5</i>	0.919 <i>36.6</i>	1.211 <i>52.9</i>	1.488 <i>65.9</i>	1.895 <i>85.6</i>	2.284 <i>105.4</i>
38.10	1 1/2					0.835 <i>24.6</i>	1.110 <i>33.0</i>	1.466 <i>44.1</i>	1.806 <i>54.9</i>	2.309 <i>71.4</i>	2.793 <i>87.9</i>
44.45	1 3/4					0.977 <i>21.1</i>	1.301 <i>28.3</i>	1.721 <i>37.8</i>	2.124 <i>47.0</i>	2.722 <i>61.2</i>	3.302 <i>75.3</i>
50.80	2					1.120 <i>18.5</i>	1.492 <i>24.7</i>	1.976 <i>33.0</i>	2.441 <i>41.2</i>	3.135 <i>53.5</i>	3.811 <i>65.9</i>
63.50	2 1/2						1.874 <i>19.8</i>	2.487 <i>26.4</i>	3.077 <i>32.9</i>	3.962 <i>42.8</i>	4.829 <i>52.7</i>
76.20	3						2.256 <i>16.5</i>	2.997 <i>22.0</i>	3.713 <i>27.5</i>	4.789 <i>35.7</i>	5.847 <i>43.9</i>
88.90	3 1/2							3.508 <i>18.9</i>	4.349 <i>23.5</i>	5.616 <i>30.6</i>	6.864 <i>37.7</i>
101.60	4							4.018 <i>16.5</i>	4.984 <i>20.6</i>	6.443 <i>26.8</i>	7.882 <i>32.9</i>
127.00	5							5.039 <i>13.2</i>	6.256 <i>16.5</i>	8.096 <i>21.4</i>	9.918 <i>26.4</i>
152.40	6							6.060 <i>11.0</i>	7.527 <i>13.7</i>	9.750 <i>17.8</i>	11.954 <i>22.0</i>
203.20	8							8.102 <i>8.3</i>	10.071 <i>10.3</i>	13.057 <i>13.4</i>	16.025 <i>16.5</i>

1 Figures shown in bold are the Theoretical Weight of the tube, calculated using the nominal outside diameter and wall thickness as in the formula: $w = C (d-t)t$. Where W = Weight (kg/m), $C = 0.02466$ d = Specified OD (millimetres) t = Specified WT (millimetres)

2 Figures shown in italics are the Theoretical Bursting Pressure of Grade 316, 304 and 321 seamless tube, calculated using Barlow's thin wall formula and where $S = 515$ MPa: $P = \frac{2st}{D}$

Where: P = Theoretical Bursting Pressure (MPa) S = Tensile Strength (MPa) t = Wall thickness (millimetres) D = Outside diameter (millimetres)

For Theoretical Bursting Pressure of Grades 316, 304 and 321 welded tube, multiply the figures shown in the table by 0.85 (Weld Joint Efficiency).

For Theoretical Bursting Pressure of Grades 316L and 304L seamless tube $S = 485$ MPa, multiply the figure shown in the table by 0.9417.

For Theoretical Bursting Pressure of Grades 316L and 304L welded tube, multiply the figures shown in the table by 0.8005 ($S = 485$ MPa x 0.85 Weld Joint Efficiency).

This Table is a guide only and should not be used to determine availability of products. Call your supplier or ASSDA to determine availability.

TUBE TO TUBE UNION



TUBE TO MALE PIPE

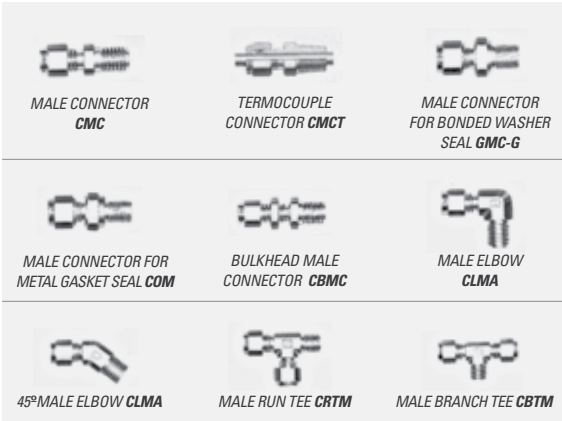

TUBE TO FEMALE PIPE

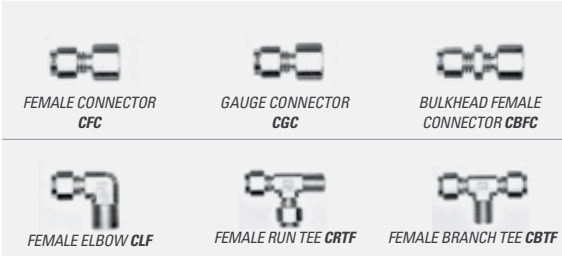

STUB TUBE CONNECTOR

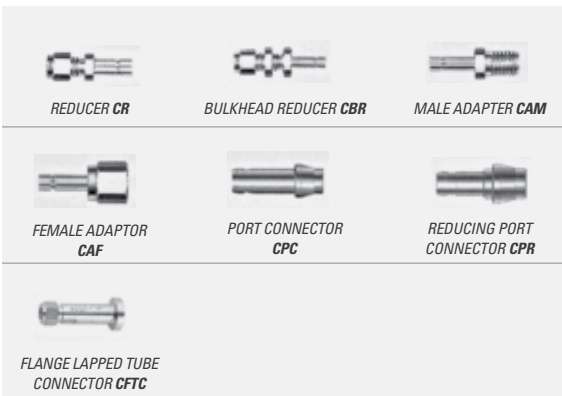

TUBE TO AN TUBE



TUBE TO SAE/MS O-RING

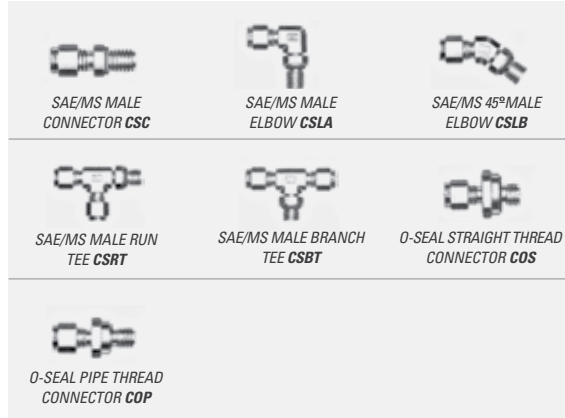

TUBE TO WELD END

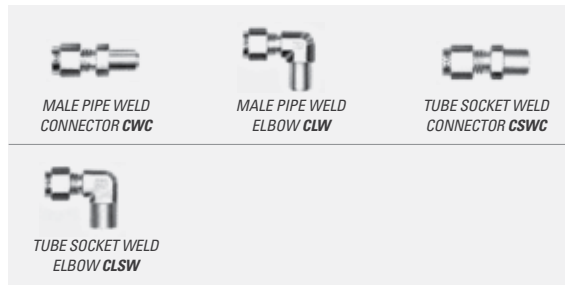

PLUG & CAP



TUBE TO TUBE UNION

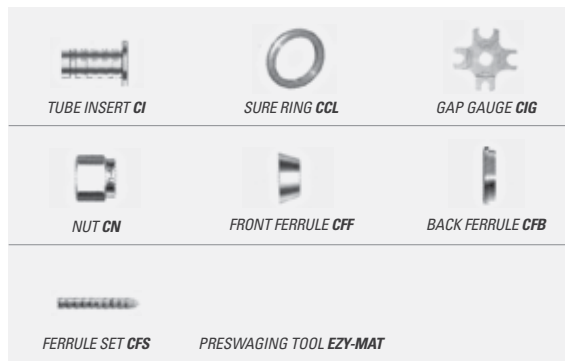

AUXILIARY TUBE FITTINGS

ADJUSTABLE FEET & INSERTS

(M16 THREAD)

STAINLESS STEEL ADJUSTABLE FOOT

BASE SIZE	304
32mm	★
50mm	★
65mm	★



SQUARE TUBE NYLON INSERTS

BASE SIZE	304
25mm	★
32mm	★
38mm	★

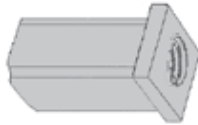

STAINLESS STEEL TUBE SADDLES

SIZE	304
1/4"	★
3/8"	★
1/2"	★
3/4"	★
1"	★
1 1/4"	★
1 1/2"	★
2"	★



STAINLESS STEEL CONCEALED FLANGES

TUBE SIZE	304	316
1/2"	★	★
3/4"	★	★
1"	★	★
1 1/4"	★	★
1 1/2"	★	★
2"	★	★
2 1/2"	☆	★
3"	☆	★
4"	☆	★



T316 SOLID PUSH-IN CAPS

TO SUIT O.D	316
25.4mm	★
31.8mm	★
38.1mm	★
50.8mm	★
63.5mm	★
76.2mm	★



FACE RINGS

SPECIFICATIONS: FLAT FACE RINGS

MANUFACTURE: FLAT FACE MANUFACTURED FROM SHEET

SPECIFICATIONS: ANGLE NECK FACE RINGS

MANUFACTURE: ANGLE NECK MANUFACTURED FROM ANGLE

FLAT FACE RINGS



INSIDE DIAMETER	MATERIAL	GRADE 316
mm		
38.1	3mm Thick	☆
50.8	3 mm Thick	★
63.5	3 mm Thick	★
76.2	3mm Thick	☆

ANGLE NECK RINGS



INSIDE DIAMETER	MATERIAL	GRADE 316
mm		
38.1	PRESSED	★
50.8	PRESSED	★
63.5	PRESSED	★
76.2	20 x 20 x 3	★
101.6	20 x 20 x 3	★
127	25 x 25 x 3	★
152.4	25 x 25 x 3	★
203	25 x 25 x 3	★
254	30 x 30 x 4	★
305	30 x 30 x 4	★
356	40 x 40 x 5	☆
406	40 x 40 x 5	★
457	40 x 40 x 5	★
508	40 x 40 x 5	★

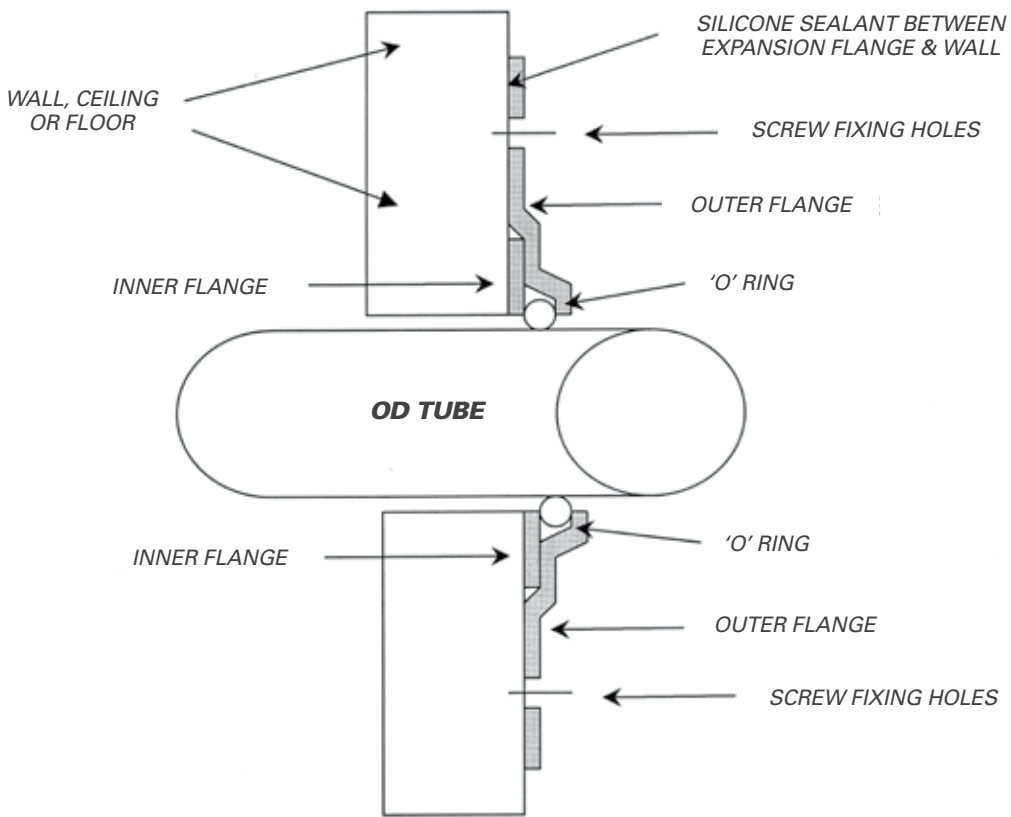

SIZE	304
3/4"	★
1"	★
1 1/4"	★
1 1/2"	★
2"	★
2 1/2"	★
3"	★
4"	★
6"	★

- Provides a hygienic seal for wall, floor and ceiling penetrations of process piping in food and beverage plants
- Allows lineal expansion and contraction of pipework without permitting the entry of water, dust, vapours or insects
- Can be adapted for steam pipes or non-standard tube sizes
- Suitable for cip hosedowns
- Eliminate potential health hazards
- Minimises damage during refurbishment
- Professional finish

HD A-JUSTA-FOOT™

There are two types of HEAVY DUTY A-JUSTA-FOOT™. In both types the whole unit is made in STAINLESS STEEL. The HD range is ball jointed and has 50 degree angle adjustment.

The HDA range has a swivelling stud which is totally captive in the base, it has 10 degree angle adjustment and is ideal where there is a requirement to resist and upward force.

Both the HD and HDA ranges have anti-slip pads, and are available with BOLTDOWN holes in the base.

They can both be adjusted in position under the machine and have high load ratings.

To compliment the feet there is a range of Threaded Tube Ends, in round and square, which are designed to be welded into the tube.

HD = HEAVY DUTY A-JUSTA-FOOT™ 121 SERIES (STAINLESS STEEL) COMPLETE WITH ANTI SLIP PADS

MIDWAY CODES	PART NO.	SIZE	A	B	C	D	E	RATING
	121/40/M8/60	40xM8	40	60	30	18	M8	500kg
	121/40/M10/60	40xM10	40	60	30	18	M10	700kg
TFAJFHD1260090	121/60/M12/90	60xM12	60	90	40	17	M12	1200kg
	121/60/M12/190	60xM12x190	60	190	40	17	M12	1200kg
TFAJFHD1660090	121/60/M16/90	60xM16	60	90	40	17	M16	2000kg
TFAJFHD1660190	121/60/M16/190	60xM16x190	60	190	40	17	M16	2000kg
	121/60/M20/90	60xM20	60	90	40	17	M20	3500kg
	121/60/M20/190	60xM20x190	60	190	40	17	M20	3500kg
	121/60/M24/90	60xM24	60	90	40	17	M24	4500kg
	121/60/M24/190	60xM24x190	60	190	40	17	M24	4500kg
	121/90/M12/90	90xM12	90	90	48	19	M12	1200kg
	121/90/M12/190	90xM12x190	90	190	48	19	M12	1200kg
TFAJFHD1690090	121/90/M16/90	90xM16	90	90	48	19	M16	2000kg
	121/90/M16/190	90xM16x190	90	190	48	19	M16	2000kg
	121/90/M20/90	90xM20	90	90	48	19	M20	3500kg
	121/90/M20/190	90xM20x190	90	190	48	19	M20	3500kg
	121/90/M24/90	90xM24	90	90	48	19	M24	4500kg
	121/90/M24/190	90xM24x190	90	190	48	19	M24	4500kg
	121/125/M12/90	125xM12	125	90	45	22	M12	1200kg
	121/125/M16/90	125xM16	125	90	45	22	M16	2000kg
	121/125/M16/190	125xM16x190	125	190	45	22	M16	2000kg
	121/125/M20/90	125xM20	125	90	45	22	M20	3500kg
	121/125/M20/190	125xM20x190	125	190	45	22	M20	3500kg
	121/125/M24/90	125xM24	125	90	45	22	M24	4500kg
	121/125/M24/190	125xM24x90	125	190	45	22	M24	4500kg

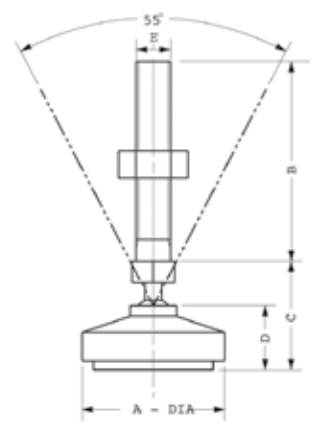

HDA STANDARD 221 SERIES

	A	B	C	D	E	F	G
	BASE	BASE HEIGHT	OVERALL HEIGHT	STUD	THREAD LENGTH	PIVOT ANGLE	RATING
HDA221/90/M16/70	90	45	115	M16	70	10 deg	2000kg
HDA221/90/M16/170	90	45	215	M16	170	10 deg	2000kg
HDA221/90/M20/70	90	45	115	M20	70	10 deg	3000kg
HDA221/90/M20/170	90	45	215	M20	170	10 deg	3000kg
HDA221/90/M24/70	90	45	115	M24	70	10 deg	4000kg
HDA221/90/M24/170	90	45	215	M24	170	10 deg	4000kg

The A-JUSTA-FOOT™ is a multi-adjustable pedestal foot, ideal for industrial, commercial, workshop or food industry applications.

The special insert in the base helps to absorb vibration and means your machinery will stay exactly where you put it.

A-JUSTA-FOOT™ is available in a large variety of sizes. Special requirements can often be produced.

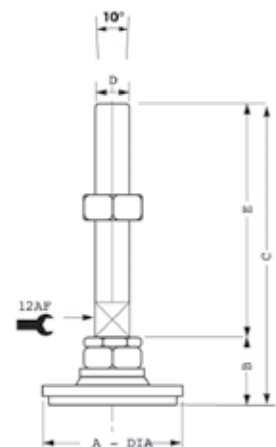

BALL JOINTED A-JUSTA-FOOT™ (STAINLESS STEEL) 21 SERIES

MIDWAY CODES	PART NO.	SIZE	A	B	C	D	E	RATING
TFAJFBJ0840080	21/40/M8/80	40xM8	40	80	33	20	M8	350kg
TFAJFBJ1040060	21/40/M10/60	40xM10	40	60	33	20	M10	500kg
TFAJFBJ1260065	21/60/M12/65	60xM12	60	65	51	25	M12	800kg
TFAJFBJ1660065	21/60/M16/65	60xM16	60	65	51	25	M16	1000kg
TFAJFBJ1290065	21/90/M12/65	90xM12	90	65	51	25	M12	800kg
TFAJFBJ1690065	21/90/M16/65	90xM16	90	65	51	25	M16	1000kg
TFAJFBJ1660165	21/60/M16/165	60xM16	60	165	51	25	M16	1000kg
TFAJFBJ1690165	21/90/M16/165	90xM16	90	165	51	25	M16	1000kg
	21/60/M20/165	60xM20	60	100	51	25	M20	1000kg
	21/60/M20/165	60xM20	60	165	51	25	M20	1000kg
	21/90/M20/100	90xM20	90	100	51	25	M20	1000kg
TFAJFBJ2090165	21/90/M20/165	90xM20	90	165	51	25	M20	1000kg

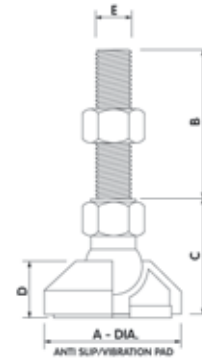

SLIP-ON

A-JUSTA-FOOT™ is available in other stud lengths (B) as required

BOLT DOWN A-JUSTA-FOOT™ (STAINLESS STEEL) 31 SERIES

MIDWAY CODES	PART NO.	SIZE	A	B	C	D	E	RATING
TFAJFBD0840080	31/40/M8/80*	40xM8	60	80	33	20	M8	350kg
TFAJFBD1040060	31/40/M10/60*	40xM10	60	60	33	20	M10	500kg
TFAJFBD1260065	31/60/M12/65	60xM12	80	65	51	23	M12	800kg
TFAJFBD1660065	31/60/M16/65	60xM16	80	65	51	23	M16	1000kg
TFAJFBD1660165	31/60/M16/165	60xM16	80	165	51	23	M16	1000kg
	31/60/M20/100	60xM20	80	100	51	23	M20	1000kg
	31/60/M20/165	60xM20	80	165	51	23	M20	1000kg
TFAJFBD2060165	31/90/M12/65	90xM12	60	65	51	25	M12	800kg
TFAJFBD1690065	31/90/M16/65	90xM16	60	65	51	25	M16	1000kg
TFAJFBD1690165	31/90/M16/165	90xM16	60	165	51	25	M16	1000kg
	31/90/M20/100	90xM20	60	100	51	25	M20	1000kg
TFAJFBD2090165	31/90/M20/165	90xM20	60	165	51	25	M20	1000kg

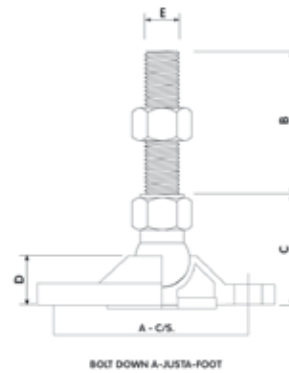

BOLT DOWN A-JUSTA-FOOT

A-JUSTA-FOOT™ is available in other stud lengths (B) as required

* Denotes also available with single hole flange



31 SERIES

FIXED A-JUSTA-FOOT™ (STAINLESS STEEL) 41 SERIES

MIDWAY CODES	PART NO.	SIZE	A	B	D	E	RATING
TFAJFFX084035	41/40/M8/35	40xM8	40	35	20	M8	350kg
TFAJFFX104035	41/40/M10/35	40xM10	40	35	20	M10	500kg
	41/60/M12/60	60xM12	60	60	25	M12	800kg

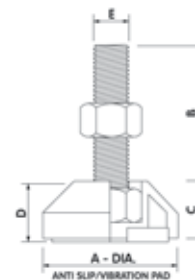

41 SERIES

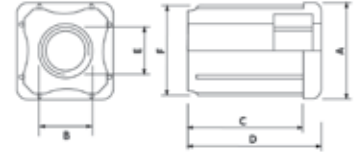

SQUARE THREADED TUBE END (STAINLESS STEEL)
11 SERIES (G) IS RECOMMENDED ID TUBE SIZE

SQUARE THREADED TUBE END
 + SQUARE PLUG

MIDWAY CODES	PART NO.	SIZE	A	B	C	D	E	F	G	RATING
	11/9/M8	19xM8	19	M8	22.5	24.8	9	16	15-16	50kg
TFAJFSTI0825	11/25M8	25xM8	25	M8	39	44	10	23.5	22-23	250kg
TFAJFSTI1025	11/25/M10	25xM10	25	M10	39	44	11	23.5	22-23	250kg
TFAJFSTI1225	11/25/M12	25xM12	25	M12	39	44	13	23.5	22-23	250kg
TFAJFSTI1625	11/25/M16	25xM16	25	M16	39	44	16.5	23.5	22-23	250kg
	11/30/M8	30xM8	30	M8	39	45	10	26.8	26-27	350kg
	11/30/M10	30xM10	30	M10	39	45	11	26.8	26-27	350kg
	11/30/M12	30xM12	30	M12	39	45	13	26.8	26-27	350kg
	11/30/M16	30xM16	30	M16	39	45	16.5	26.8	26-27	350kg
TFAJFSTI0832	11/32/M8	32xM8	32	M8	39	45	10	30	28-29	350kg
TFAJFSTI1032	11/32/M10	32xM10	32	M10	39	45	11	30	28-29	350kg
TFAJFSTI1232	11/32/M12	32xM12	32	M12	39	45	13	30	28-29	350kg
TFAJFSTI1632	11/32/M16	32xM16	32	M16	39	45	16.5	30	28-29	350kg
	11/35/M8	35xM8	35	M8	39	45	11	32.2	31-32	350kg
	11/35/M10	35xM10	35	M10	39	45	11	32.2	31-32	400kg
	11/35/M12	35xM12	35	M12	39	45	13	32.2	31-32	400kg
TFAJFSTI1635	11/35/M16	35xM16	35	M16	39	45	16.5	32.2	31-32	400kg
TFAJFSTI0838	11/38/M8	38xM8	38	M8	41	45	10	36	35-36	500kg
TFAJFSTI1038	11/38/M10	38xM10	38	M10	41	47	17.7	36	35-36	500kg
TFAJFSTI1238	11/38/M12	38xM12	38	M12	41	47	13	36	35-36	500kg
TFAJFSTI1638	11/38/M16	38xM16	38	M16	41	47	18	36	35-36	500kg
	11/40/M10	40xM10	40	M10	39	45	11	36.8	36-37	500kg
	11/40/M12	40xM12	40	M12	39	45	13	36.8	36-37	500kg
	11/40/M16	40xM16	40	M16	39	45	16.5	36.8	36-37	500kg
TFAJFSTI1050	11/51/M10	51xM10	51	M10	39	45	11	48	47-48	750kg
TFAJFSTI1250	11/51/M12	51xM12	51	M12	39	45	13	48	47-48	750kg
TFAJFSTI1650	11/51/M16	51xM16	51	M16	39	45	18	48	47-48	750kg
	11/51/M20	51xM20	51	M20	39	45	18	48	47-48	750kg



ROUND THREADED TUBE END (STAINLESS STEEL)
81 SERIES

ROUND THREADED TUBE END

MIDWAY CODES	PART NO.	SIZE	A	B	C	D	E	F	G	RATING
	81/25/M8	25xM8	25	M8	38	46.5	11	23	22	100kg
	81/25/M10	25xM10	25	M10	38	46.5	12	23	22	100kg
	81/25/M12	25xM12	25	M12	38	46.5	14	23	22	100kg
	81/32/M10	32xM10	32	M10	39	45	12	29.5	28-29	250kg
	81/32/M12	32xM12	32	M12	39	45	14	29.5	28-29	250kg
	81/32/M16	32xM16	32	M16	39	45	18	29.5	28-29	250kg
TFAJFRTI1038	81/38/M10	38xM10	38	M10	38	45	12	35.5	35-36	300kg
TFAJFRTI1238	81/38/M12	38xM12	38	M12	38	45	14	35.5	35-36	300kg
TFAJFRTI1638	81/38/M16	38xM16	38	M16	38	45	18	35.5	35-36	300kg
	81/40/M8	40xM8	40	M8	39	45	11	36.8	36-37	350kg
	81/40/M10	40xM10	40	M10	39	45	12	36.8	36-37	500kg
	81/40/M12	40xM12	40	M12	39	45	14	36.8	36-37	500kg
	81/40/M16	40xM16	40	M16	39	45	18	36.8	36-37	500kg
TFAJFRTI1250	81/51/M12	51xM12	51	M12	38	45	14	48	47-48	450kg
TFAJFRTI1650	81/51/M16	51xM16	51	M16	38	45	18	48	47-48	450kg
TFAJFRTI1665	81/62/M16	62xM16	62	M16	38	45	18	60.5	60-61	450kg

WELDING CONSUMABLES AND FINISHING PRODUCTS

For the welding of standard and special grades of stainless steel, we offer a complete range of covered electrodes, flux cored and solid welding wires. To complement the consumables we also supply a full list of cleaning and pickling products for stainless steel.

COVERED ELECTRODES / SOLID AND FLUX CORED WELDING WIRES

We supply covered electrodes and welding wires for

welding all of the common ferritic, martensitic, duplex and austenitic stainless grades, as well as nickel based alloys. The range also includes specific products for dissimilar welding between stainless and mild steel or stainless and nickel based alloys.

For more information please refer to the following weld metal composition tables for each of the product groups or request one of our more detailed brochures or data sheets.

COVERED ELECTRODES

Electrode designation Avesta Welding	Coating type	Weld metal composition, typical values, %							Typical ferrite ¹⁾	Standard designations	
		C	Si	Mn	Cr	Ni	Mo	Other		EN 1600/ EN/ISO 14172	AWS A5.4/ AWS A5.11
248 SV	Rutile	0.03	0.5	3.0	16.0	5.5	1.2	N 0.12	5 FN	–	–
308L/MVR-2D	Rutile-acid	0.03	0.7	0.9	20.0	10.5	–	–	10 FN	E 19 9 L R	E308L-17
308L/MVR-3D	Rutile-acid	0.02	0.8	0.6	19.5	10.0	–	–	10 FN	E 19 9 L R	E308L-17
308L/MVR-4D	Rutile-acid	0.02	0.8	0.6	19.5	10.5	–	–	5 FN	E 19 9 L R	E308L-17
308L/MVR-PW	Rutile-acid	0.02	0.8	1.0	19.0	10.0	–	–	5 FN	E 19 9 L R	E308L-17
308L/MVR-VDX	Rutile-acid	0.02	0.7	0.8	19.0	10.0	–	–	5 FN	E 19 9 L R	E308L-17
308L/MVR basic	Basic	0.03	0.4	1.3	20.0	10.0	–	–	8 FN	E 19 9 L B	E308L-15
308L/MVR-16	Rutile	0.02	0.6	0.6	19.3	10.0	–	–	10 FN	E 19 9 L R	E308L-16
308L/MVR Cryo	Rutile	0.02	0.5	1.7	19.0	10.3	–	–	4 FN	E 19 9 L R	E308L-16
308/308H AC/DC	Rutile-acid	0.06	0.7	1.1	20.0	10.0	–	–	5 FN	E 19 9 R	E308H-17
347/MVNB-3D	Rutile-acid	0.02	0.8	0.8	19.5	10.0	–	Nb \geq 10xC ²⁾	8 FN	E 19 9 Nb R	E347-17
347/MVNB basic	Basic	0.06	0.4	1.0	19.5	10.0	–	Nb \geq 10xC ²⁾	8 FN	E 19 9 Nb B	E347-15
347/MVNB-16	Rutile	0.02	0.7	0.6	19.5	10.0	–	Nb \geq 10xC ²⁾	8 FN	E 19 9 Nb R	E347-16
347/MVNB Bi-free	Rutile	0.02	0.7	0.6	19.5	10.0	–	Nb \geq 10xC ²⁾	8 FN	E 19 9 Nb R	E347-16
316L/SKR-2D	Rutile-acid	0.03	0.8	0.8	18.0	12.0	2.8	–	10 FN	E 19 12 3 L R	E316L-17
316L/SKR-3D	Rutile-acid	0.02	0.8	0.7	18.5	12.0	2.7	–	10 FN	E 19 12 3 L R	E316L-17
316L/SKR-4D	Rutile-acid	0.02	0.8	0.7	18.0	12.0	2.6	–	8 FN	E 19 12 3 L R	E316L-17
316L/SKR-PW	Rutile-acid	0.02	0.8	1.0	18.0	12.0	2.8	–	10 FN	E 19 12 3 L R	E316L-17
316L/SKR-VDX	Rutile-acid	0.02	0.7	0.7	18.5	12.5	2.8	–	5 FN	E 19 12 3 L R	E316L-17
316L/SKR basic	Basic	0.02	0.2	1.3	18.5	12.0	2.6	–	6 FN	E 19 12 3 L B	E316L-15
316L/SKR-16	Rutile	0.02	0.6	0.6	18.5	12.0	2.7	–	6 FN	E 19 12 3 L R	E316L-16
316L/SKR Cryo	Rutile	0.02	0.3	1.2	17.2	11.9	2.7	–	4 FN	E 19 12 3 L R	E316L-16
316/316H AC/DC	Rutile-acid	0.06	0.8	1.0	19.0	12.0	2.8	–	5 FN	E 19 12 2 R	E316H-17
16.8.2	Rutile-acid	0.05	0.45	1.6	15.5	8.0	1.2	–	3 FN	–	E16-8-2-17
318/SKNb-3D	Rutile-acid	0.02	0.8	0.8	18.5	12.0	2.8	Nb \geq 10xC ²⁾	10 FN	E 19 12 3 Nb R	E318-17
317L/SNR-3D	Rutile-acid	0.02	0.7	0.9	19.0	13.0	3.7	–	10 FN	–	E317L-17
SLR AC/DC	Rutile-acid	0.02	0.8	1.0	18.5	13.5	4.0	–	10 FN	E 19 13 4 N L R	–
LDX 2101-3D	Rutile-acid	0.04	0.8	0.7	23.5	7.0	0.3	N 0.14	45 FN	E 23 7 N L R	–
LDX 2101-4D	Rutile-acid	0.03	0.9	0.6	23.5	7.4	0.4	N 0.16	35 FN	E 23 7 N L R	–
2304-3D	Rutile-acid	0.02	0.8	0.8	24.5	9.0	–	N 0.12	30 FN	E 23 7 N L R	–
2205-2D	Rutile-acid	0.02	0.8	0.7	22.5	9.5	3.0	N 0.15	30 FN	E 22 9 3 N L R	E2209-17
2205-3D	Rutile-acid	0.02	0.8	0.7	23.0	9.5	3.0	N 0.15	30 FN	E 22 9 3 N L R	E2209-17
2205-4D	Rutile-acid	0.02	0.8	0.7	23.0	9.5	3.0	N 0.15	30 FN	E 22 9 3 N L R	E2209-17
2205-PW	Rutile-acid	0.02	0.8	0.8	23.0	9.5	3.0	N 0.17	30 FN	E 22 9 3 N L R	E2209-17
2205 Basic	Basic	0.03	0.5	1.2	23.5	9.0	3.0	N 0.16	40 FN	E 22 9 3 N L B	E2209-15
2507/P100-3D	Rutile-acid	0.02	0.9	0.9	25.5	9.2	3.6	N 0.24	30 FN	E 25 9 4 N L R	E2594-17
2507/P100-4D	Rutile-acid	0.03	0.8	0.8	25.0	9.3	3.6	N 0.22	30 FN	E 25 9 4 N L R	E2594-17
2507/P100	Rutile	0.03	0.5	1.3	25.5	10.0	3.6	N 0.23	30 FN	E 25 9 4 N L R	E2594-16
254 SFER	Rutile	0.03	0.4	2.6	25.0	21.0	2.5	N 0.14	0 FN	E 25 22 2 N L R	–
308L/MVR-NF	Rutile	0.02	0.5	1.9	19.4	12.9	–	–	0 FN	(E19 9 L R)	(E308L-16)
316L/SKR-NF	Rutile	0.03	0.4	2.3	17.5	13.8	2.5	–	0 FN	(E 19 12 3 L R)	E316L-16
904L-3D	Rutile-acid	0.02	0.7	1.2	20.5	25.0	4.5	Cu 1.5	0 FN	E 20 25 5 Cu N L R	E385-17
904L-PW	Rutile-acid	0.02	1.0	1.2	20.0	24.5	4.5	Cu 1.5	0 FN	E 20 25 5 Cu N L R	(E385-17)
383 AC/DC	Rutile-acid	0.02	0.9	0.9	27.0	32.0	3.7	Cu 1.0	0 FN	E 27 31 4 Cu L R	E383-17
P12-R	Basic	0.02	0.4	0.4	21.5	Bal.	9.5	Nb 2.2; Fe 3	0 FN	ENiCr21MoFeNb	ENiCrMo-12
P625	Basic	0.02	0.5	0.2	21.5	Bal.	9.5	Nb 3.5; Fe 1.5	0 FN	ENiCr22Mo9Nb	ENiCrMo-3
P16	Basic	0.01	0.15	0.2	23.5	Bal.	15.5	–	0 FN	ENiCr25Mo16	ENiCrMo-13
P54	Basic	0.02	0.2	2.6	25.5	25.5	5.0	N 0.35; Cu 0.8	0 FN	–	–
307 AC/DC	Rutile-acid	0.07	0.8	4.0	20.0	10.5	0.8	–	5 FN	E 18 9 Mn Mo R	E307-17
309L-3D	Rutile-acid	0.02	0.8	0.8	23.0	13.0	–	–	15 FN	E 23 12 L R	E309L-17
309L-4D	Rutile-acid	0.02	0.8	1.0	23.5	13.0	–	–	15 FN	E 23 12 L R	E309L-17
309L basic	Basic	0.03	0.2	1.9	24.0	13.0	–	–	15 FN	E 23 12 L B	E309L-15
309L-16	Rutile	0.02	0.6	0.7	23.0	13.0	–	–	15 FN	E 23 12 L R	E309L-16
309L Bi-free	Rutile	0.02	0.6	0.8	23.0	13.0	–	–	15 FN	E 23 12 L R	E309L-16
308LMo-3D	Rutile-acid	0.02	0.8	0.7	19.7	9.9	2.5	–	20 FN	–	E308LMo-17
P5-2D	Rutile-acid	0.03	0.8	1.0	22.0	13.5	2.7	–	20 FN	E 23 12 2 L R	E309LMo-17
P5-3D	Rutile-acid	0.02	0.8	0.8	22.5	13.5	2.5	–	20 FN	E 23 12 2 L R	E309LMo-17
P5-4D	Rutile-acid	0.02	0.7	1.0	23.0	13.0	2.5	–	20 FN	E 23 12 2 L R	E309LMo-17
P5-PW	Rutile-acid	0.02	1.1	1.0	22.5	13.5	2.9	–	20 FN	E 23 12 2 L R	E309LMo-17
P5-VDX	Rutile-acid	0.02	0.9	0.9	22.5	13.5	2.5	–	20 FN	E 23 12 2 L R	E309LMo-17
P5 basic	Basic	0.03	0.2	2.0	22.5	13.0	2.7	–	15 FN	E 23 12 2 L B	E309LMo-15
P7 AC/DC	Rutile-acid	0.09	0.8	0.8	29.0	9.5	–	–	40 FN	E 29 9 R	(E312-17)
P10	Basic	0.03	0.3	7.0	16.0	Bal.	–	Nb 2.2; Fe 5	0 FN	ENiCr15Fe6Mn	ENiCrFe-3
309 AC/DC	Rutile-acid	0.05	0.8	1.0	24.0	13.5	–	–	15 FN	–	E309-17
309Nb-3D	Rutile-acid	0.03	0.8	0.8	23.0	13.0	–	Nb 0.8	15 FN	–	E309Nb-17*)
310-3D	Rutile-acid	0.10	0.5	2.1	26.0	21.0	–	–	0 FN	E 25 20 R	E310-17
253 MA-3D	Rutile-acid	0.08	1.5	0.7	22.0	10.5	–	N 0.18; REM	10 FN	E 21 10 R	–
253 MA-NF	Rutile-acid	0.08	0.7	1.0	19.0	10.0	–	N 0.16; REM	0 FN	–	–
353 MA	Basic	0.07	0.7	1.4	27.5	33.0	–	REM	0 FN	–	–

¹⁾ The ferrite content of pure weld metal. FN 0 – 18 in Schaeffler-DeLong, FN >18 in WRC-92. ²⁾ Max. 1.0% Nb. *) Also designated E309Cb-17

COVERED ELECTRODES

Electrode designation Avesta Welding	Mechanical properties, typical values						Lateral expansion	Brinell hardness	Approvals ¹⁾
	R _{p0.2} N/mm ²	R _m N/mm ²	A ₅ %	Impact strength, KV, J					
				+20°C	Low temp.				
248 SV	510	760	30	115	–		260	–	
308L/MVR-2D	395	550	41	65	55 (–40°C)		210	CWB	
308L/MVR-3D	470	570	37	60	55 (–40°C)		200	CE, DNV, TÜV	
308L/MVR-4D	420	520	35	54	38 (–40°C)		210	CE, TÜV	
308L/MVR-PW	430	580	39	60	50 (–40°C)		210	–	
308L/MVR-VDX	450	600	35	55	40 (–40°C)		210	CWB	
308L/MVR basic	420	560	38	95	42 (–196°C)	0.60 mm	200	CE, TÜV	
308L/MVR-16	470	570	37	60	55 (–40°C)		200	–	
308L/MVR Cryo	450	570	43	–	35 (–196°C)	0.55 mm	200	–	
308/308H AC/DC	450	605	37	55	50 (–40°C)		210	CE, CWB, TÜV	
347/MVNB-3D	470	620	35	55	45 (–40°C)		225	CE, CWB, DNV, TÜV	
347/MVNB basic	520	680	30	90	65 (–40°C)		255	CE, TÜV	
347/MVNB-16	460	610	35	55	45 (–40°C)		225	TÜV	
347/MVNB Bi-free	460	610	35	55	45 (–40°C)		225	–	
316L/SKR-2D	420	575	37	55	55 (–40°C)		210	CWB, DNV, TÜV	
316L/SKR-3D	445	590	36	55	55 (–40°C)		210	CE, DNV, TÜV	
316L/SKR-4D	480	590	34	60	55 (–20°C)		210	CE, TÜV	
316L/SKR-PW	455	590	36	60	60 (–40°C)		210	CE, CWB, DNV, TÜV	
316L/SKR-VDX	480	630	30	50	35 (–40°C)		210	CE, CWB, DNV, TÜV	
316L/SKR basic	430	565	34	95	40 (–196°C)	0.50 mm	210	CE, TÜV	
316L/SKR-16	470	560	40	55	55 (–20°C)		210	TÜV	
316L/SKR Cryo	450	570	35	–	42 (–196°C)	0.70 mm	210	–	
316/316H AC/DC	470	615	35	50	–		210	CE, CWB, TÜV	
16.8.2	470	740	40	80	50 (–40°C)		210	–	
318/SKNb AC/DC	470	605	34	60	50 (–40°C)		220	CE, DNV, TÜV	
317L/SNR AC/DC	485	615	32	45	–		210	CWB, DNV	
SLR AC/DC	490	635	31	45	30 (–40°C)		225	CE, TÜV	
LDX 2101-3D	640	800	25	45	28 (–40°C)		260	TÜV	
LDX 2101-4D	640	785	25	50	36 (–40°C)		260	–	
2304-3D	640	780	23	40	25 (–40°C)		260	–	
2205-2D	640	825	33	55	40 (–40°C)		240	–	
2205-3D	620	810	25	45	35 (–40°C)		240	CE, CWB, TÜV	
2205-4D	630	820	25	45	35 (–40°C)		240	CE, TÜV	
2205-PW	635	830	25	55	40 (–40°C)		240	CE, CWB, DNV, TÜV,	
2205 basic	645	840	26	100	80 (–46°C)		240	–	
2507/P100-3D	720	900	23	32	30 (±0°C)		250	–	
2507/P100-4D	700	880	24	40	30 (–46°C)		250	–	
2507/P100	700	900	26	80	55 (–40°C)		250	–	
254 SFER	440	660	32	55	–		200	–	
308L/MVR-NF	400	520	40	–	37 (–196°C)	0.60 mm	200	–	
316L/SKR-NF	430	560	37	–	42 (–196°C)	0.60 mm	210	–	
904L-3D	400	565	34	70	–		200	CE, TÜV	
904L-PW	400	600	35	70	–		200	–	
383 AC/DC	410	620	33	55	–		200	–	
P12-R	480	730	37	90	70 (–196°C)		220	CE, CWB, TÜV	
P625	480	770	30	60	50 (–40°C)		220	–	
P16	550	780	35	60	40 (–40°C)		220	–	
P54	500	700	20	50	30 (–70°C)		220	–	
307 AC/DC	465	605	35	45	–		200	–	
309L-3D	450	550	35	50	45 (–40°C)		210	CE, CWB, DNV, TÜV	
309L-4D	460	590	29	50	–		210	CE, TÜV	
309L basic	460	595	33	85	70 (–40°C)		210	–	
309L-16	450	550	35	50	–		210	–	
309L Bi-free	450	550	35	50	45 (–40°C)		210	–	
308L-Mo-3D	560	700	35	62	–		220	–	
P5-2D	450	625	30	35	–		220	–	
P5-3D	490	640	30	30	–		220	CE, CWB, DNV, TÜV	
P5-4D	530	660	28	40	–		220	CE	
P5-PW	525	660	31	25	–		225	–	
P5-VDX	545	685	30	40	–		225	–	
P5 basic	465	615	30	50	35 (–40°C)		230	TÜV	
P7 AC/DC	620	810	18	25	–		270	–	
P10	380	630	39	115	80 (–196°C)		180	–	
309 AC/DC	435	580	30	45	–		210	CWB	
309Nb-3D	525	650	35	50	–		210	–	
310-3D	430	625	35	80	35 (–196°C)		190	CWB	
253 MA-3D	535	725	37	60	–		215	CE	
253 MA-NF	470	630	35	70	–		210	–	
353 MA	385	565	33	85	–		200	–	

¹⁾ For detailed information, contact Avesta Welding.

Wire type and designation Avesta				Weld metal composition, typical values								ferrite ¹⁾	Standard designations	
Welding	MIG	TIG	SAW	C	Si	Mn	Cr	Ni	Mo	Other	EN ISO 14343/ EN ISO 18274		AWS A5.9/ AWS A5.14	
248 SV	X	X	X	0.02	0.35	1.3	16.0	5.5	1.0	–	10 FN	–	–	
308L-Si/MVR-Si	X	X	–	0.02	0.85	1.8	20.0	10.5	–	–	11 FN	19 9 L Si	ER308LSi	
308L/MVR	X	X	X	0.02	0.40	1.7	20.0	10.0	–	–	8 FN	19 9 L	ER308L	
308H	X	X	X	0.05	0.40	1.8	20.0	9.0	–	–	10 FN	19 9 H	ER308H	
347-Si/MVNB-Si	X	X	–	0.05	0.85	1.2	19.5	10.0	–	Nb>12xC	10 FN	19 9 Nb Si	ER347Si	
347/MVNB	–	X	X	0.04	0.40	1.3	19.5	9.5	–	Nb>12xC	6 FN	19 9 Nb	ER347	
316L-Si/SKR-Si	X	X	–	0.02	0.85	1.7	18.5	12.0	2.6	–	9 FN	19 12 3 L Si	ER316LSi	
316L/SKR	X	X	X	0.02	0.40	1.7	18.5	12.0	2.6	–	8 FN	19 12 3 L	ER316L	
318-Si/SKNb-Si	X	X	–	0.04	0.85	1.3	19.0	12.0	2.6	Nb>12xC	10 FN	19 12 3 Nb Si	–	
318/SKNb	–	X	X	0.04	0.40	1.3	19.0	12.0	2.6	Nb>12xC	8 FN	19 12 3 Nb	ER318	
317L/SNR	X	X	X	0.02	0.40	1.7	19.0	13.5	3.5	–	9 FN	19 13 4 L	ER317L	
LDX 2101	X	X	X	0.02	0.40	0.5	23.0	7.0	<0.5	N 0.14	40 FN	23 7 N L	–	
2304	X	X	X	0.02	0.40	0.5	23.5	7.0	<0.5	N 0.14	40 FN	23 7 N L	–	
2205	X	X	X	0.02	0.50	1.6	23.0	8.5	3.1	N 0.17	50 FN	22 9 3 N L	ER2209	
2507/P100	X	X	X	0.02	0.35	0.4	25.0	9.5	4.0	N 0.25	50 FN	25 9 4 N L	ER2594	
254 SFER	–	X	–	0.02	0.1	4.5	25.0	22.0	2.2	N 0.13	0 FN	25 22 2 N L	–	
904L	X	X	X	0.01	0.35	1.7	20.0	25.5	4.5	Cu 1.5	0 FN	20 25 5 Cu L	ER385	
P12	X	X	X	0.01	0.10	0.1	22.0	65	9.0	Nb 3.6; Fe<1	0 FN	NiCr22Mo9Nb	ERNiCrMo-3	
P12-0 ^{Nb}	X	X	X	0.01	0.10	0.1	22.0	65	9.0	Nb<0.1; Fe<1; W 2.8	0 FN	NiCr22Mo20	ERNiCrMo-20	
P16	X	X	X	0.01	0.10	0.2	25.0	60	15.0	Nb<0.1; Fe<1	0 FN	NiCr25Mo16	ERNiCrMo-13	
P54	X	X	–	0.02	0.20	5.1	26.0	22.0	5.5	N 0.35; Cu 0.9	0 FN	–	–	
307-Si	X	X	–	0.09	0.80	7.0	19.0	8.0	–	–	0 FN	18 8 Mn	–	
309L-Si	X	X	–	0.02	0.80	1.8	23.5	13.5	–	–	13 FN	23 12 L Si	ER309LSi	
309L	–	X	X	0.02	0.40	1.8	23.5	14.0	–	–	11 FN	23 12 L	ER309L	
P5	X	X	X	0.02	0.35	1.5	21.5	15.0	2.7	–	9 FN	23 12 2 L	(ER309LMo) ²⁾	
P7	X	X	X	0.11	0.45	1.9	30.0	9.5	–	–	60 FN	29 9	ER312	
P10	X	X	–	0.03	0.10	2.9	20.0	73	–	Nb 2.5; Fe <2	0 FN	NiCr20Mn3Nb	ERNiCr-3	
310	X	X	–	0.12	0.35	1.6	25.5	21.0	–	–	0 FN	25 20	ER310	
253 MA	X	X	X	0.07	1.60	0.6	21.0	10.0	–	N 0.15; REM	9 FN	21 10	–	
353 MA	X	X	–	0.05	0.85	1.6	27.5	35.0	–	N 0.15; REM	0 FN	–	–	

¹⁾ The ferrite content of pure weld metal. FN 0 – 18 in Schaeffler-DeLong, FN >18 in WRC-92. ²⁾ Cr lower and Ni higher than standard.

Avesta MIG

high productivity when welding thin materials in all positions

MIG/MAG is a rapid method for fully and semi-automatic welding. Depending on the arc's characteristics, welding can be carried out in all positions. Because the weld metal has low oxide and slag levels, its mechanical properties are very good. This is particularly true of impact strength. Suitable metal thicknesses are 2 - 10 mm.

Avesta TIG

beautiful finishes and exceptional impact strength

Good TIG welds look superb. The weld metal also has the best mechanical properties – impact strength at low temperatures is particularly impressive. For this reason, TIG welding is often used for low-temperature applications. The heat input in TIG welding is normally low. Thus, there is the least possible impact on the parent metal. As the arc and weld pool are highly controllable, TIG is very suitable for the all-position single-sided welding of pipes and other components. Suitable metal thicknesses are 0.3 - 3 mm. TIG is also used for welding root beads. Subsequent welding is then with a method that has a higher productivity.

Wire designation Avesta Welding	Mechanical properties, typical values (MIG wire)						Approvals ¹⁾		
	R _{p0.2} N/mm ²	R _m N/mm ²	A ₅ %	Impact strength KV, J		Brinell hardness	MIG	TIG	SAW / Flux combination
				+20°C	Low temp.				
248 SV	460	840	23	80	–	260	–	–	–
308L-Si/MVR-Si	420	600	36	110	60 (–196°C)	200	CE, DNV, TÜV	CE, DNV, TÜV	–
308L/MVR	390	590	38	110	50 (–196°C)	200	CE, DNV, TÜV	CE, DNV, TÜV	CE (801, 805) DNV (801) TÜV (801, 805, 807)
308H	400	610	37	95	–	210	CE	CE	–
347-Si/MVNB-Si	430	620	36	100	90 (–40°C)	210	CE, TÜV	CE, TÜV	–
347/MVNB ²⁾	450	640	34	60	–	220	TÜV	TÜV	CE (801) TÜV (801, 807)
316L-Si/SKR-Si	400	600	36	110	50 (–196°C)	210	CE, DNV, TÜV	CE, DNV, TÜV	–
316L/SKR	390	580	37	100	50 (–196°C)	210	CE, DNV, TÜV	CE, DNV, GL, TÜV	CE (801, 805) TÜV (801, 805, 807)
318-Si/SKNb-Si	420	600	33	85	80 (–40°C)	220	CE, TÜV	CE, TÜV	–
318/SKNb ²⁾	490	660	30	50	–	220	TÜV	TÜV	CE (805, 807) TÜV (801, 807)
317L/SNR	420	630	31	85	–	200	–	–	–
LDX 2101	520	710	30	150	110 (–40°C)	240	TÜV	–	CE (805), TÜV (805)
2304	520	710	30	150	110 (–40°C)	240	TÜV	TÜV	CE (805), TÜV (805)
2205	550	770	30	150	110 (–40°C)	230	CE, DNV, TÜV	CE, DNV, TÜV	CE (805), DNV (805) TÜV (805, 807)
2507/P100	570	830	29	140	–	280	TÜV	CE, TÜV	–
254 SFER ³⁾	440	650	35	180	130 (–196°C)	200	–	–	–
904L	340	570	38	130	100 (–196°C)	170	CE, TÜV	CE, TÜV	CE (805), TÜV (805)
P12	480	750	42	170	150 (–40°C)	220	CE, TÜV	CE, TÜV	–
P12-0 ^{Nb}	380	630	36	240	220 (–70°C)	210	–	–	–
P16	470	700	33	120	–	220	–	–	–
P54	480	750	35	90	–	220	–	–	–
307-Si	470	710	42	120	110 (–40°C)	220	CE, DNV, TÜV	CE, TÜV	–
309L-Si	400	600	32	110	–	200	CE, TÜV	CE, TÜV	–
309L ²⁾	410	580	36	70	–	–	TÜV	TÜV	DNV (805)
P5	390	610	31	75	60 (–40°C)	210	CE, DNV, TÜV	CE, DNV, TÜV	DNV (801, 805)
P7	560	750	25	40	–	240	CE	–	DNV (801)
P10	410	660	33	–	–	200	TÜV	CE	–
310	360	570	35	120	–	210	–	–	–
253 MA	440	680	38	130	–	210	CE	–	–
353 MA	320	590	43	160	–	200	–	–	–

Avesta SAW

high productivity when welding thick materials in the flat position

When welding in the flat position, SAW has a deposition rate of up to 8kg per hour. This is the highest achieved by any convention method. The weld metal has beautiful, even surfaces. An agglomerated flux (Avesta 801, 805 or 807) is used in submerged arc welding. Because heat input is relatively high, thin materials may be deformed. Suitable metal thicknesses are 10 mm upwards. Some caution must also be exercised when welding fully austenitic steels.

Avesta fluxes for SAW

Flux 801

A chromium-compensated neutral flux for welding standard steels such as EN 1.4307/ASTM 304L and 1.4432/316L.

Flux 805

A chromium-compensated flux with high basicity. Used for welding austenitic and duplex stainless steels as well as nickel base alloys.

Flux 807

A flux that is not chromium-compensated, but has a high basicity. Used for welding EN 1.4307/ASTM 304L and 1.4432/316L when there is a requirement that ferrite content must not exceed FN 8.

FCW designation Avesta Welding	Weld metal composition, typical values. %								Typical ferrite ¹⁾	Standard designations	
	C	Si	Mn	Cr	Ni	Mo	Other	EN ISO 17633 EN ISO 12153		AWS A5.22/ AWS A5.34	
FCW-2D 308L/MVR	0.03	0.7	1.5	19.8	10.2	-	-	7 FN	T 19 9 L R M/C 3	E308LT0-4/-1	
FCW 308L/MVR-PW	0.03	0.7	1.6	19.2	10.2	-	-	9 FN	T 19 9 L P M/C 1	E308LT1-4/-1	
FCW-2D 308H	0.06	0.4	1.5	19.0	9.5	-	-	5 FN	-	E308HT0-4/-1	
FCW 308H-PW	0.06	0.4	1.5	19.0	9.5	-	-	5 FN	-	E308HT1-4/-1	
FCW 308L/MVR Cryo	0.03	0.6	1.8	19.0	11.0	-	-	4 FN	T 19 9 L P M/C 1	E308LT1-4/-1	
FCW-2D 347/MVNB	0.03	0.7	1.4	19.0	10.4	-	Nb >8xC	7 FN	T 19 9 Nb R M/C 3	E347T0-4/-1	
FCW 347/MVNB-PW	0.03	0.7	1.6	19.0	10.5	-	Nb >8xC	7 FN	T 19 9 Nb P M/C 1	E347T1-4/-1	
FCW 347/MVNB-LF-PW	0.03	0.7	1.4	18.7	10.4	-	Nb >8xC	5 FN	T 19 9 Nb P M/C 1	E347T1-4/-1	
FCW-2D 316L/SKR	0.03	0.7	1.5	19.0	12.0	2.7	-	8 FN	T 19 12 3 L R M/C 3	E316LT0-4/-1	
FCW 316L/SKR-PW	0.03	0.7	1.5	18.0	12.5	2.7	-	6 FN	T 19 12 3 L P M/C 1	E316LT1-4/-1	
FCW 316L/SKR Cryo	0.03	0.7	1.4	18.1	12.5	2.1	-	4 FN	T 19 12 3 L P M/C 1	E316LT1-4/-1	
FCW-2D 317L/SNR	0.03	0.7	1.3	18.5	13.3	3.4	-	5 FN	-	E317LT0-4/-1	
FCW-2D LDX 2101	0.03	0.7	0.8	24.0	9.0	0.3	N 0.14	30 FN	T 23 7 N L R M/C 3	-	
FCW LDX 2101-PW	0.03	0.7	0.9	24.0	9.0	0.3	N 0.13	30 FN	T 23 7 N L P M/C 1	-	
FCW-2D 2304	0.03	0.7	0.8	24.0	9.0	0.3	N 0.14	30 FN	T 23 7 N L R M/C 3	-	
FCW 2304-PW	0.03	0.7	0.8	24.0	9.0	0.3	N 0.14	40 FN	T 23 7 N L P M/C 1	-	
FCW-2D 2205	0.03	0.7	0.8	22.7	9.0	3.2	N 0.13	40 FN	T 22 9 3 N L R M/C 3	E2209T0-4/-1	
FCW 2205-PW	0.03	0.8	0.9	22.7	9.0	3.2	N 0.13	40 FN	T 22 9 3 N L P M/C 1	E2209T1-4/-1	
FCW 2507/P100-PW	0.03	0.7	0.9	25.3	9.8	3.7	N 0.23	35 FN	T Z 25 9 4 N L P M21 2	E2594T1-4/-1	
FCW-2D P10	0.05	0.4	3.2	20.0	Bal.	-	Nb 2.5;<Fe 2.0	0 FN	Ni Cr Mn 3 Nb B M21 3	ENiCr-3T0-4/-1	
FCW P12-PW	0.02	0.5	0.2	20.5	Bal.	9.0	Nb 3.3;<Fe 1.0	0 FN	Ni Cr 22 Mo 9 Nb B M21 1	ENiCrMo-3T1-4	
FCW-2D 309L	0.03	0.7	1.4	22.8	12.5	-	-	18 FN	T 23 12 L R M/C 3	E309LT0-4/-1	
FCW 309L-PW	0.03	0.6	1.5	23.0	12.8	-	-	18 FN	T 23 12 L P M/C 1	E309LT1-4/-1	
FCW-2D P5	0.03	0.6	1.4	22.7	12.3	2.7	-	25 FN	T 23 12 2 L R M/C 3	E309LMoT0-4/-1	
P5-PW	0.03	0.4	1.4	23.0	12.8	2.5	-	25 FN	T 23 12 2 L P M/C 1	E309LMoT1-4/-1	

¹⁾ The ferrite content of pure weld metal. FN 0 – 18 in Schaeffler-DeLong, FN >18 in WRC-92.

Avesta FCW-2D

FCW-2D has been specially developed for rapid, cost-efficient welding. It is particularly recommended for horizontal-vertical and flat fillet welds; flat butt welds and various types of over-layer welding. Suitable metal thicknesses are 2.5 mm upwards.

Avesta FCW-PW

FCW-PW has been especially developed for position welding. The slag solidifies at a high temperature and helps to form and support the weld pool. The PW type wires weld with a stable arc and an easily controlled weld pool, which makes them very user friendly. FCW-PW can be used for all types of welding in all positions.

FCW designation Avesta Welding	Mechanical properties, typical values						Hardness Brinell	Approvals ¹⁾
	R _{p0.2} N/mm ²	R _m N/mm ²	A ₅ %	Impact strength, KV, J				
				+20°C	Low temp.			
FCW-2D 308L/MVR	380	560	40	60	35 (-196°C)	200	CE, CWB, TÜV	
FCW 308L/MVR-PW	390	570	39	60	-	200	CE, CWB, TÜV	
FCW-2D 308H	390	580	41	90	50 (-70°C)	210	TÜV	
FCW 308H-PW	390	580	41	90	50 (-70°C)	210	-	
FCW 308L/MVR Cryo	390	550	40	80	45 (-196°C) Lat.exp.>0.38 mm	210	-	
FCW-2D 347/MVNB	420	600	35	75	-	220	CE, TÜV	
FCW 347/MVNB-PW	410	580	34	70	-	220	TÜV	
FCW 347/MVNB-LF-PW	400	600	35	75	38 (-120°C)	220	-	
FCW-2D 316L/SKR	400	560	38	55	35 (-120°C)	210	CE, CWB, DNV, GL, TÜV	
FCW 316L/SKR-PW	400	560	37	60	55 (-40°C)	210	CE, CWB, DNV, GL, TÜV	
FCW 316L/SKR Cryo	390	550	40	75	40 (-196°C) Lat.exp.>0.38 mm	210	-	
FCW-2D 317L/SNR	420	570	32	50	45 (-60°C)	210	-	
FCW-2D LDX 2101	580	760	25	63	45 (-40°C)	240	TÜV	
FCW LDX 2101-PW	575	765	30	70	50 (-40°C)	240	-	
FCW-2D 2304	580	760	25	50	40 (-20°C)	240	TÜV	
FCW 2304-PW	580	760	25	70	50 (-20°C)	240	CE, TÜV	
FCW-2D 2205	600	800	27	60	40 (-40°C)	240	BV, CE, CWB, DNV, GL, TÜV	
FCW 2205-PW	600	800	27	80	55 (-40°C)	240	BV, CE, CWB, DNV, GL, TÜV	
FCW 2507/P100-PW	670	890	26	60	40 (-46°C)	250	-	
FCW-2D P10	380	640	41	130	115 (-196°C)	200	-	
FCW P12-PW	460	750	40	75	45 (-196°C) Lat.exp.>0.38 mm	220	-	
FCW-2D 309L	400	540	35	60	45 (-60°C)	210	CE, CWB, DNV, GL, TÜV	
FCW 309L-PW	390	550	35	55	-	210	BV, CWB, DNV, GL, TÜV	
FCW-2D P5	500	700	30	55	-	220	CE, DNV, GL, TÜV	
P5-PW	470	660	29	55	-	220	-	

PICKLING AND CLEANING CHEMICALS

Pickling pastes, gels and bath solutions are used to restore stainless steel surfaces, plus remove welding oxides and the underlying chromium depleted layer. During the process micro-slag inclusions and other contaminants that may cause local corrosion are also removed.

Product	Form	Strength	Characteristics	Sizes
GreenOne 120 Pickling Paste	Paste	Light	Non toxic, easy to apply and rinse, good for pickling of shiny surfaces without dulling	2L
Classic 122 Pickling Gel	Gel	Medium	Suitable for all grades, more free flowing than paste and heat stable in warmer conditions	2L , 10L 1000L
BlueOne 130 Pickling Paste	Paste	Strong	Pickling for standard applications with very low nitric fumes, easy to apply and rinse	2L , 10L 1000L
RedOne 140 Pickling Paste	Paste	Very Strong	For heavy / tough applications and higher alloyed grades, fast effect even at low temperatures	2L , 10L 1000L
Classic 204 Pickling Spray	Spray Gel	Very Strong	Suitable for all grades, provides good adhesion and produces a matt finish, strong with fast results	25L 1000L
RedOne 240 Pickling Spray	Spray Gel	Strong	For heavy / tough applications, good for overnight as it does not dry out, produces a brighter finish	25L
Classic 302 Pickling Bath	Liquid	Concentrate	Concentrated for use in pickling baths, suitable on all stainless including higher alloyed grades	25L 1000L

RELATED FINISHING CHEMICALS

The pickling and cleaning processes must often be completed with different treatments to reach the required result or to meet environmental requirements. Finishing chemicals are for surface treatment in all steps of the pickling process. Cleaners to remove organic contaminants

before pickling, passivators to accomplish the desired after-treatment and neutraliser to handle the waste water. The range also includes a drop test to be able to distinguish between different steel grades.

Product	Form	Strength	Characteristics	Sizes
Classic Cleaner 401	Liquid	Strong	Strong cleaner, removes surface rust, oil, grease and calcium stains, improves surface finish	2L , 25L 1000L
Neutraliser 502 Agent	Liquid	n/a	Handles acetic waste with waste water adjusted to pH value of 7 to 10, dissolved metals precipitated	2L , 25L
FinishOne 630 Final Rinse/Passivator	Liquid	Light	Passivates, cleans and removes contaminants, no hazardous waste, non-dangerous	2L , 25L 1000L

1 PIECE 800 WOG BALL VALVE - THREADED

SPECIFICATIONS:	INVESTMENT CAST BODY & END CAP
END TYPE:	THREADED BSP OR NPT BOTTOM-LOADED, BLOW-OUT-PROOF STEM, ADJUSTABLE STEM PACKING STAINLESS STEEL HANDLE WITH VINYL GRIP
OPTION:	LOCKING DEVICE
APPLICATIONS:	FOR GENERAL CHEMICAL & INDUSTRIAL SERVICES
PRESSURE RATING:	800 PSI WOG (NON-SHOCK)
STEAM RATING:	150 PSI WSP
TEMPERATURE RANGE:	-29°C + 200°C

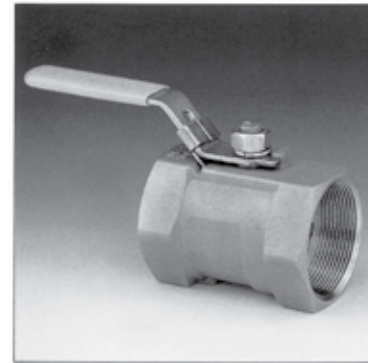

MATERIALS LIST

NO.	PART NAME	SPECIFICATION
1	BODY	ASTM A351 GR.CF8M
2	CAP	STAINLESS STEEL 316
3	STEM	STAINLESS STEEL 316
4	BALL	ASTM A351 GR.CF8M
5	BALL SEAT	PTFE
6	THRUST WASHER	PTFE
7	CAP SEAT	PTFE
8	PACKING	PTFE
9	GLAND	STAINLESS STEEL 304
10	WASHER	STAINLESS STEEL 304
11	HANDLE NUT	STAINLESS STEEL 304
12	HANDLE	STAINLESS STEEL 304
13	HANDLE SLEEVE	VINYL GRIP
14*	LOCKING PLATE	STAINLESS STEEL 304

(*) Option

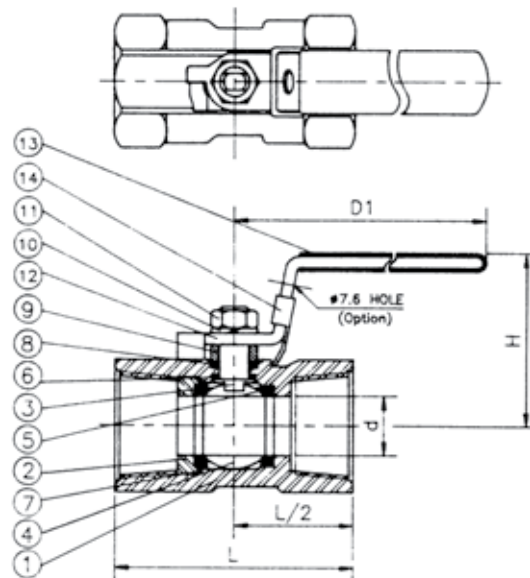

DIMENSIONS (mm)

SIZE	d	L	H	D1	Cv FACTOR
Inch					
1/4	5	39	36	63	1
3/8	7	44.5	37	74	2.5
1/2	9.2	56.5	44	91	5.5
3/4	12.5	58.5	47	91	10
1	15	71.5	51	106	15.5
1 1/4	20	78.5	54	106	20
1 1/2	25	83.5	67	129	37
2	32	100	72	129	60

PRESSURE TEMPERATURE RATINGS

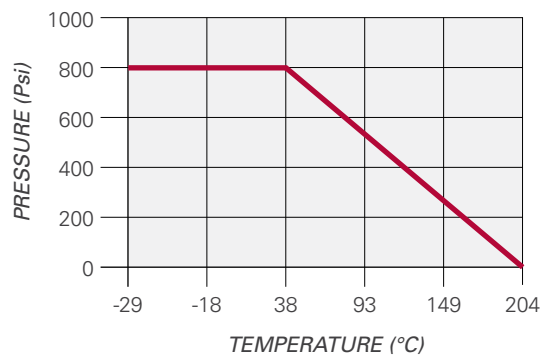

2 PIECE FULL PORT 1000 WOG BALL VALVE - THREADED

SPECIFICATIONS:	INVESTMENT CAST BODY & END CAP
END TYPE:	THREADED BSP OR NPT BOTTOM-LOADED, BLOW-OUT-PROOF STEM, ADJUSTABLE STEM PACKING EASY ACTUATOR MOUNTING STAINLESS STEEL HANDLE WITH VINYL GRIP
OPTION:	LOCKING DEVICE
APPLICATIONS:	FOR GENERAL CHEMICAL & INDUSTRIAL SERVICES
PRESSURE RATING:	1000 PSI WOG (NON-SHOCK)
STEAM RATING:	150 PSI WSP
TEMPERATURE RANGE:	-29°C + 200°C



MATERIALS LIST

NO.	PART NAME	SPECIFICATION
1	BODY	ASTM A351 GR.CF8M
2	END CAP	ASTM A351 GR.CF8M
3	BALL	ASTM A351 GR.CF8M
4	BALL Seats	PTFE
5	STEM	S.S.316
6	END SEAL	PTFE
7	THRUST WASHER	PTFE
8	STEM PACKINGS	PTFE
9	GLAND	STAINLESS STEEL 304
10	HANDLE	STAINLESS STEEL 304
11	HANDLE WASHER	STAINLESS STEEL 304
12	HANDLE NUT	STAINLESS STEEL 304
13	HANDLE SLEEVE	VINYL GRIP
14*	LOCKING PLATE	STAINLESS STEEL 304

(*) Option

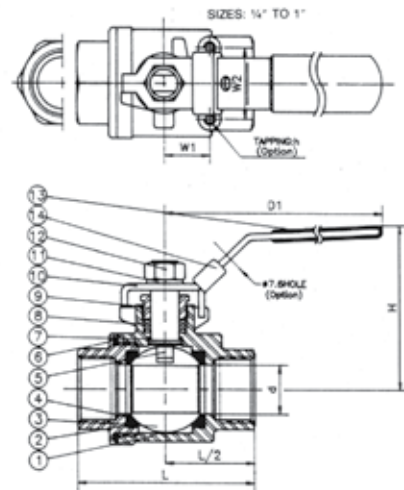

DIMENSIONS (mm)

SIZE	d	L	H	D1	W1	W2	h	Cv FACTOR
Inch								
1/4	11.0	59.5	50	97	12.7	28.5	10-24 UNC	6
3/8	12.7	60.5	50	97	12.7	28.5	10-24 UNC	12
1/2	15	64	60	126	12.7	28.5	10-24 UNC	19
3/4	20	76	63	126	22.4	35.0	10-24 UNC	37
1	25	90.2	80	145	22.4	35.0	10-24 UNC	64
1 1/4	32	98.8	84	145	25.4	38.1	1/4-20 UNC	103
1 1/2	38	116	96	204	25.4	38.1	1/4-20 UNC	143
2	50.8	135.5	104	204	25.4	38.1	1/4-20 UNC	360
2 1/2	65	163	144	248	N/A	58.0	1/4-20 UNC	440
3	80	191	156	248	N/A	70.0	1/4-20 UNC	520

PRESSURE TEMPERATURE RATINGS

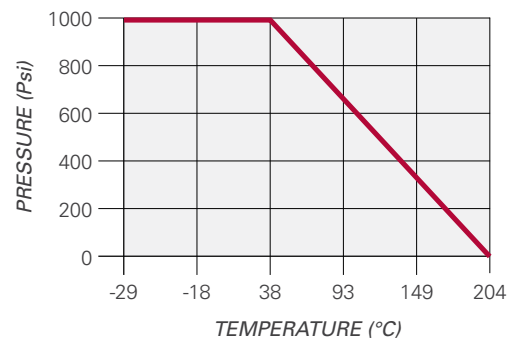

3 PIECE 1000 WOG BALL VALVE - THREADED

SPECIFICATIONS:	INVESTMENT CAST BODY & END CAP
END TYPE:	THREADED BSP OR NPT, BUTTWELD, SOCKET WELD 3PC DESIGN FOR FAST INSTALLATION & SIMPLE MAINTENANCE, BOTTOM-LOADED, BLOW-OUT-PROOF STEM, ADJUSTABLE STEM PACKING STAINLESS STEEL HANDLE WITH VINYL GRIP
OPTION:	LOCKING DEVICE
APPLICATIONS:	FOR GENERAL CHEMICAL & INDUSTRIAL SERVICES
PRESSURE RATING:	1000 PSI WOG (NON-SHOCK)
STEAM RATING:	150 PSI WSP
TEMPERATURE RANGE:	-29°C + 200°C

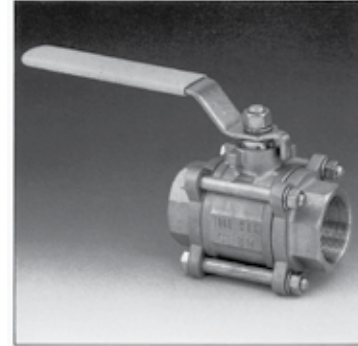

MATERIALS LIST

NO.	PART NAME	SPECIFICATION
1	BODY	ASTM A351 GR.CG8M
2	END CAPS	ASTM A351 GR.CG8M
3	BALL	ASTM A351 GR.CG8M
4	STEM	STAINLESS STEEL 316
5	BALL SEATS	PTFE
6	STEM PACKING	PTFE
7	GLAND	STAINLESS STEEL 304
8	END SEALS	PTFE
9	THRUST WASHER	PTFE
10	HANDLE	STAINLESS STEEL 304
11	HANDLE NUT	STAINLESS STEEL 304
12	HANDLE WASHER	STAINLESS STEEL 304
13	LOCKING PLATE	STAINLESS STEEL 304
14	BOLTS	STAINLESS STEEL 304
15	BOLT NUTS	STAINLESS STEEL 304
16	BOLT WASHERS	STAINLESS STEEL 304
17	HANDLE SLEEVE	VINYL GRIP

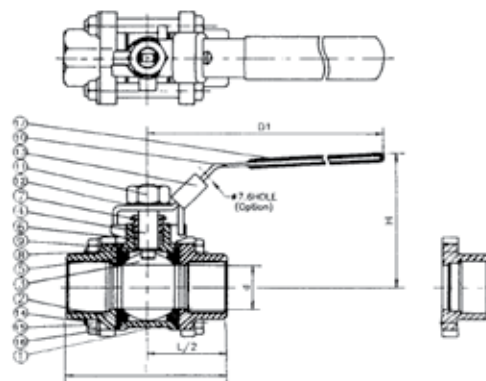

DIMENSIONS (mm)

SIZE	d	L	H	D1	Cv FACTOR
Inch					
1/4	11.2	65	50	97	6
3/8	12.7	65	50	37	12
1/2	16	71	60	126	19
3/4	20	85	63	126	37
1	25	95	80	145	64
1 1/4	32	112	86	145	103
1 1/2	38.1	123	94	204	143
2	50.8	141	104	204	360
2 1/2	65	173	140	248	440
3	80	192	152	248	520
4	100	225	180	292	820

PRESSURE TEMPERATURE RATINGS

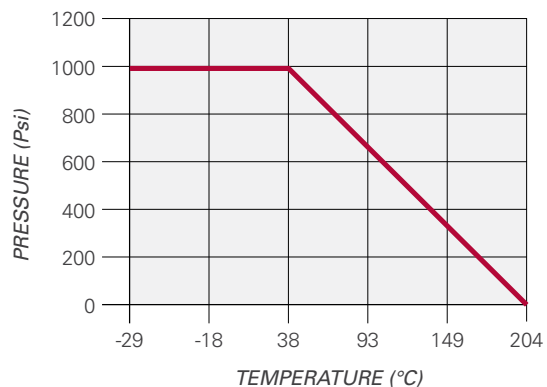

3 WAY REDUCED PORT 1000 WOG BALL VALVE - THREADED 'L' PORT

SPECIFICATIONS:	INVESTMENT CAST BODY & END CAP
END TYPE:	THREADED BSP OR NPT BOTTOM-LOADED, BLOW-OUT-PROOF STEM, ADJUSTABLE STEM PACKING, REINFORCED PTFE MINIMIZE SEAT DISTORTION, EASY ACTUATOR MOUNTING, STAINLESS STEEL HANDLE WITH VINYL GRIP
OPTION:	LOCKING DEVICE
APPLICATIONS:	FOR GENERAL CHEMICAL & INDUSTRIAL SERVICES
PRESSURE RATING:	1000 PSI WOG (NON-SHOCK)
STEAM RATING:	150 PSI WSP
TEMPERATURE RANGE:	-29°C + 200°C



MATERIALS LIST

NO.	PART NAME	SPECIFICATION
1	BODY	ASTM A351 GR.CF8M
2	END CAP	ASTM A351 GR.CF8M
3	BALL	ASTM A351 GR.CF8M
4	BALL SEATS	REINFORCED PTFE
5	STEM	STAINLESS STEEL 316
6	THRUST WASHER	REINFORCED PTFE
7	STEM PACKINGS	REINFORCED PTFE
8	END SEAL	REINFORCED PTFE
9	GLAND	STAINLESS STEEL 304
10	HANDLE	STAINLESS STEEL 304
11	FLOW INDICATOR PLATE	ALUMINIUM
12	HANDLE WASHER	STAINLESS STEEL 304
13	HANDLE NUT	STAINLESS STEEL 304
14	LOCKING PLATE	STAINLESS STEEL 304
15	HANDLE SLEEVE	VINYL GRIP

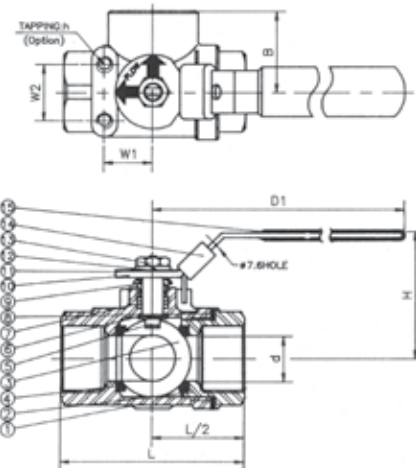

DIMENSIONS (mm)

SIZE	d	L	H	D1	B	W1	W2	h	Cv FACTOR
<i>Inch</i>									
3/8	10.0	64	53	97	32	22.4	35.0	10-24 UNC	6.0
1/2	12.7	64	53	97	32	22.4	35.0	10-24 UNC	6.0
3/4	16.0	76	63	126	38	22.4	35.0	10-24 UNC	12.0
1	20.0	87	66	126	43.5	22.4	35.0	10-24 UNC	14.0
1 1/4	25.0	96	81	145	48	22.4	35.0	10-24 UNC	24.0
1 1/2	32.0	114	83	145	57	25.4	38.1	1/4-20 UNC	30.0
2	38.1	142	96	204	71	25.4	38.1	1/4-20 UNC	50.0

PRESSURE TEMPERATURE RATINGS

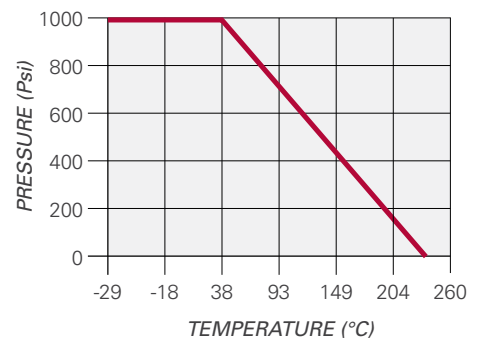

3 WAY REDUCED PORT 1000 WOG BALL VALVE - THREADED 'T' PORT

SPECIFICATIONS:	INVESTMENT CAST BODY & END CAP
END TYPE:	THREADED BSP OR NPT, BOTTOM-LOADED, BLOW-OUT-PROOF STEM, ADJUSTABLE STEM PACKING, REINFORCED PTFE MINIMIZE SEAT DISTORTION, EASY ACTUATOR MOUNTING, STAINLESS STEEL HANDLE WITH VINYL GRIP
OPTION:	LOCKING DEVICE
APPLICATIONS:	FOR GENERAL CHEMICAL & INDUSTRIAL SERVICES
PRESSURE RATING:	1000 PSI WOG (NON-SHOCK)
STEAM RATING:	150 PSI WSP
TEMPERATURE RANGE:	-29°C + 200°C



MATERIALS LIST

NO.	PART NAME	SPECIFICATION
1	BODY	ASTM A351 GR.CF8M
2	END CAP	ASTM A351 GR.CF8M
3	BLIND CAP	ASTM A351 GR.CF8M
4	BALL	ASTM A351 GR.CF8M
5	BALL SEATS	REINFORCED PTFE
6	STEM	STAINLESS STEEL 316
7	THRUST WASHER	REINFORCED PTFE
8	END SEAL	REINFORCED PTFE
9	STEM PACKINGS	REINFORCED PTFE
10	GLAND	STAINLESS STEEL 304
11	HANDLE	STAINLESS STEEL 304
12	FLOW INDICATOR PLATE	ALUMINIUM
13	HANDLE WASHER	STAINLESS STEEL 304
14	HANDLE NUT	STAINLESS STEEL 304
15	LOCKING PLATE	STAINLESS STEEL 304
16	HANDLE SLEEVE	VINYL GRIP

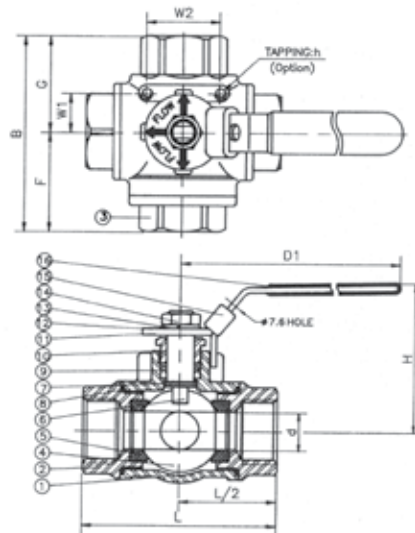

DIMENSIONS (mm)

SIZE	d	L	H	D1	B	F	G	W1	W2	h
<i>Inch</i>										
1/2	12.7	75	59	126	71	33.5	37.5	22.4	35.0	10-24 UNC
3/4	16.0	85	64	126	81.5	39.0	42.5	22.4	35.0	10-24 UNC
1	20.0	100	80	145	102	50.5	51.5	22.4	35.0	10-24 UNC
1 1/4	25.0	115	90	145	108.5	51.0	57.5	22.4	35.0	10-24 UNC
1 1/2	32.0	125	96	204	121	58.0	63.0	25.4	38.1	1/4-20 UNC
2	38.1	148	106	204	138.5	65.5	73.0	25.4	38.1	1/4-20 UNC

PRESSURE TEMPERATURE RATINGS

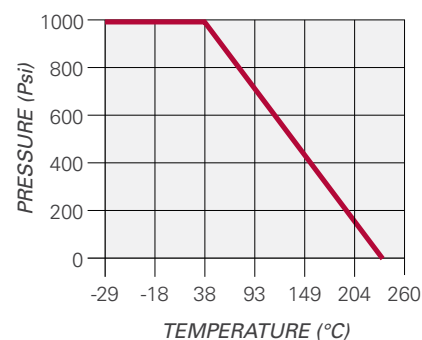

WOG CHECK VALVE / Y STRAINER

SPECIFICATIONS:	INVESTMENT CAST BODY & BONNET (SOLUTION TREATED) HIGH PERFORMANCE & LOW COST
END TYPE:	THREADED BSP OR NPT SS316 STAINLESS STEEL SCREEN / BONNETT SWING TYPE DISC
APPLICATIONS:	FOR GENERAL CHEMICAL & INDUSTRIAL SERVICES
STEAM RATING:	150 PSI WSP
TEMPERATURE RANGE:	+232°C MAX

200 WOG SWING CHECK VALVE THREADED

PRESSURE RATING: 200 PSI WOG (NON-SHOCK)

MATERIALS LIST

NO.	PART NAME	SPECIFICATION
1	BODY	ASTM A351 GR.CF8M
2	CAP	ASTM A351 GR.CF8M
3	DISC	ASTM A351 GR.CF8M
4	PLUG	STAINLESS STEEL 316
5	PIN	STAINLESS STEEL 316
6	PLUG GASKET	PTFE
7	GASKET	REINFORCED PIPE

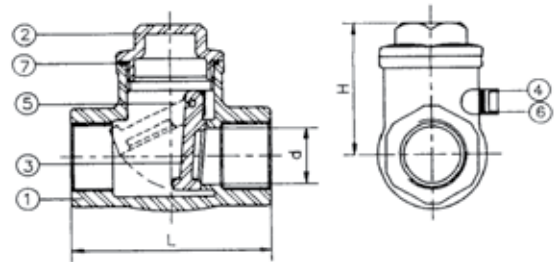

DIMENSIONS (mm)

SIZE	d	L	H	Cv FACTOR
Inch				
1/2	15	65	44	6.9
3/4	20	80	53	16.3
1	25	90	58	30
1 1/4	32	105	62	49
1 1/2	40	120	73	72
2	50	141	78	130

PRESSURE TEMPERATURE RATINGS

Below 120°C non-shock water	200psi (14kgf/cm ²) max
Below 220°C air, water, oil, gas	150psi (10kgf/cm ²) max
Saturated steam	150 psi (10kgf/cm ²) max

800 WOG Y STRAINER THREADED

PRESSURE RATING: 800 PSI WOG (NON-SHOCK)

MATERIALS LIST

NO.	PART NAME	SPECIFICATION
1	BODY	ASTM A351 GR.CF8M
2	BOTTOM PLUG	ASTM A351 GR.CF8M
3	SCREEN	STAINLESS STEEL 316
4	GASKET	REINFORCED PIPE

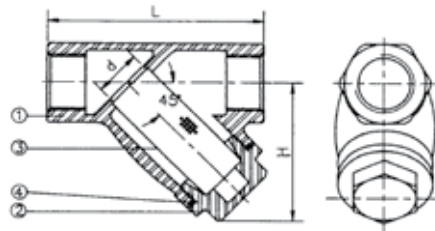

DIMENSIONS (mm)

SIZE	d	L	H	Cv FACTOR
Inch				
1/4	15	78	50	3.5
3/8	15	78	50	3.5
1/2	15	78	50	3.5
3/4	20	93	60	6.5
1	25	108	70	10
1 1/4	32	128	82	19
1 1/2	40	143	92	26
2	50	173	118	45

PRESSURE TEMPERATURE RATINGS

Below 120°C non-shock water	800psi (21kgf/cm ²) max
Below 220°C air, water, oil, gas	150psi (10kgf/cm ²) max
Saturated steam	150 psi (10kgf/cm ²) max

1000 WOG SPRING CHECK VALVE

SPECIFICATIONS:	3 PIECE INVESTMENT CAST BODY & END CAP
END TYPE:	THREADED BSP OR NPT
PRESSURE RATING:	1000 PSI WOG (NON SHOCK)
APPLICATIONS:	FOR GENERAL CHEMICAL & INDUSTRIAL SERVICES
STEAM RATING:	150 PSI WSP
TEMPERATURE RANGE:	-29°C TO 200°C MAX

MATERIALS LIST

NO.	PART NAME	SPECIFICATION
1	BODY	ASTM A351 GR.CF8M
2	END CAP	ASTM A351 GR.CF8M
3	DISC	STAINLESS STEEL T-316
4	BODY SEAL	15% GF PTFE
5	SPRING	300 SERIES STAINLESS STEEL
6	SPRING HOLDER	STAINLESS STEEL T-316
7	WASHER	304
8	NUT	304
9	BOLT	304

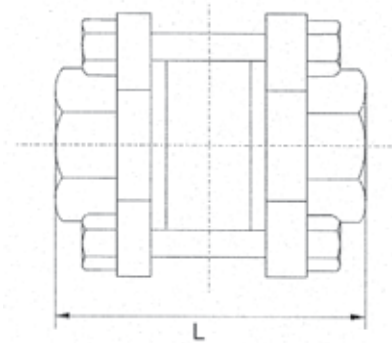

DIMENSIONS (mm)

SIZE	d	L	H	Cv FACTOR
Inch				
1/4	10	56	8	14
3/8	10	56	10	14
1/2	14	65	15	18
3/4	18.1	70	20	22
1	24.2	78	25	27.5
1 1/4	30.2	96	32	32
1 1/2	36.2	102	40	37
2	48.3	118	50	47
2 1/2	63	145	65	47
3	76	156	80	55
4	98	185	100	70

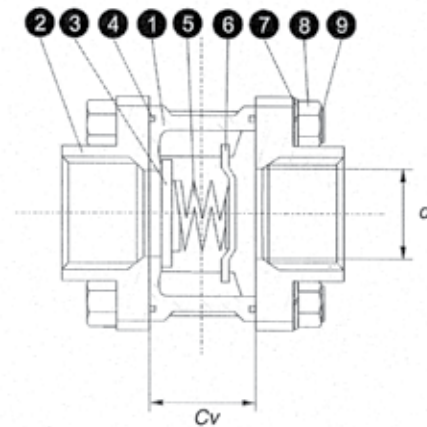

PRESSURE TEMPERATURE RATINGS

Below 120°C non-shock water	300psi (21kgf/cm ²) max
Below 220°C air, water, oil, gas	150psi (10kgf/cm ²) max
Saturated steam	150 psi (10kgf/cm ²) max

PRESSURE UNITS CROSS REFERENCE CHART

<i>psi</i>	<i>atms</i>	<i>Ft Hd. H₂O AT 20°C</i>	<i>IN H₂O</i>	<i>kg/cm²</i>	<i>METRES H₂O</i>	<i>in Hg at 20°C</i>	<i>mm Hg.</i>	<i>cm Hg.</i>	<i>bar</i>	<i>millibar (mb)</i>	<i>kPa</i>
1	0.068	2.31	27.72	0.07	0.704	2.043	51.864	5.188	0.069	68.947	6.895
14.896	1	33.659	407.513	1.033	10.351	30.019	762.48	76.284	1.013	1013	101.325
0.433	0.029	1	12	0.03	0.305	0.884	22.452	2.245	0.03	29.837	2.984
0.036	0.0025	0.833	1	0.0025	0.025	0.074	1.871	0.187	0.0025	2.486	0.49
14.233	0.968	32.867	394.408	1	10.018	39.054	737.959	73.796	0.981	980.682	98.088
1.422	0.097	3.287	39.37	0.099	1	2.905	73.796	7.379	0.98	98.068	9.807
0.489	0.033	1.131	13.575	0.034	0.345	1	25.4	2.54	0.034	33.753	3.375
0.019	0.0013	0.045	0.534	0.0014	0.0136	0.039	1	0.1	0.001	1.329	0.133
0.193	0.0131	0.445	5.34	0.014	0.136	0.393	10	1	0.0133	13.29	1.328
14.503	0.987	33.514	402.164	1.02	10.211	29.625	752.47	75.247	1	1000	100
0.014	0.0009	0.033	0.402	0.001	0.0102	0.029	0.752	0.075	0.001	1	0.1
0.145	0.0096	0.335	4.021	0.01	0.102	0.296	7.525	0.752	0.01	10	1

METRIC PRESSURE MEASUREMENT

UNIT	bar	mbar	kbar	Pa	kPa	Mpa
1 bar	1	1000	1	10 ⁵	100	0.1
1 mbar	0.001	1	10 ⁶	100	0.1	10 ⁴
1 kbar	1000	10 ⁶	1	10 ⁵	10 ⁵	100
1 Pa	10 ⁵	0.01	10 ⁵	1	0.001	10 ⁶
1 kPa	0.01	10	10 ⁵	1000	1	0.001
1 MPa	10	10 ⁴	0.01	10 ⁶	1000	1

USEFUL CONVERSION FACTORS

TO CONVERT "A"

INTO "B"

MULTIPLY BY "C"

PRESSURE

A	B	C
PSI	KPA	6.894
KPA	PSI	0.145
KPA	BAR	0.01
BAR	KPA	100
BAR	PSI	14.5
FEET OF WATER	PSI	0.4335
METRES OF WATER	KPA	9.807

VOLUME

A	B	C
LITRES	IMP GALLONS	0.222
LITRES	US GALLONS	0.263
IMP GALLONS	LITRES	4.5
US GALLONS	LITRES	3.785
US GALLONS	IMP GALLONS	0.832
IMP GALLONS	US GALLONS	1.2
LITRES	CUBIC FEET	0.035
LITRES	CUBIC METRES	0.001

VOLUME/TIME

A	B	C
US GALLONS / MIN	LITRES / SEC	0.063
CUBIC FEET / MIN	LITRES / SEC	0.472
POUNDS / HOUR	KILOGRAMS / HOUR	0.454
KILOGRAMS / HOUR	POUNDS / HOUR	2.205
LITRES / SEC	CUBIC METRES / HOUR	3.6
CUBIC METRES / HOUR	LITRES / SEC	0.278

LENGTH

A	B	C
METRES	FEET	3.281
METRES	YARDS	1.094
MILLIMETRES	INCHES	0.039
INCHES	MILLIMETRES	25.4

SPEED/VELOCITY

A	B	C
FEET / SEC	METRES / MIN	18.29
FEET / SEC	METRES / SEC	0.305
METRES / MIN	FEET / MIN	0.055
METRES / SEC	FEET / MIN	196.86

AUSTENITIC GENERAL SERVICE & WET CORROSION

COMMON NAME	UNS #	FORMS AVAILABLE	C	Cr	Ni	Mo	Ti	OTHER	TYPICAL APPLICATIONS
303	S30300	Bars	0.12	18	9	–	–	0.2 5S	Free machining steel used where extensive machining is required. Corrosion resistance and weldability inferior to 304.
304	S30400	Sheet, Coil, Plate, Bars, Welded & Seamless Pipe & Tube	0.05	18.5	8.5	–	–	–	General purpose steel with good corrosion resistance for most applications. Used for architecture, food processing, domestic sinks and tubs and deep drawing applications.
304L	S30403	Sheet, Coil, Plate, Bars, Welded & Seamless Pipe & Tube	0.025	18.5	9	–	–	–	Chemical plant and food processing equipment, where freedom from sensitisation is required in plate.
316	S31600	Sheet, Coil, Plate, Bars, Welded & Seamless Pipe & Tube	0.05	17	11	2.1	–	–	Used where higher corrosion resistance is required, i.e. Marine equipment. Can be welded up to 3mm without subsequent heat treatment.
316L	S31603	Sheet, Coil, Plate, Bars, Welded & Seamless Pipe & Tube	0.02	17	11	2.1	–	–	A low carbon modification of 316 where heavy section weldments are required without the risk of intergranular corrosion.
316Ti	S31635	Plate, Pipe & Tube	0.05	17	11	2.1	0.5	–	A titanium stabilised version of 316 used where good resistance to intergranular corrosion and high temperature strength is required.
317	S31700	Sheet, Coil & Plate	0.07	19	13	3.25	–	–	For chemical plant - has a greater corrosion resistance than 316 in certain applications, notably in contact with brines and halogen salts. Also available in a low carbon "L" grade.
904L	N08904	Sheet, Plate, Bar, Pipe & Tube	0.02	20	25	4.5	–	1.5cU	High resistance to: general corrosion in e.g. Sulphuric and acetic acids; crevice corrosion; stress corrosion cracking; pitting in chloride beading solutions. Good weldability.
254SMO	S31254	Sheet, Plate, Bar, Pipe & Tube	0.02	20	18	6	–	0.2N	Used where high resistance to chloride pitting and crevice corrosion is required, e.g. Seawater heat exchangers, bleach vats and washers in the pulp and paper industry.

AUSTENITIC HIGH TEMP GRADES

COMMON NAME	UNS #	FORMS AVAILABLE	C	Cr	Ni	Mo	Ti	OTHER	TYPICAL APPLICATIONS
321	S32100	Sheet, Coil, Plate, Bars, Welded & Seamless Pipe & Tube	0.06	18	10	–	0.5	–	Heavy weldments in chemical and other industries. Suitable for heat resisting applications to 800°C. Not suitable for bright polishing.
310	S31000	Sheet, Coil, Plate & Bars	0.12	25	20	–	–	–	Furnace parts and equipment. Resistant to temperature 900°C to 1000°C.
310S	S31008	Sheet, Plate, Bar, Tube & Pipe	0.1	21	11	–	–	0.15n 0.5Ce	Used for furnace parts, radiant shields, fluidised beds. Resistant to temperatures up to 1150°C. Possesses high strength and resistance to sigma phase formation.
153MA	S30415	Sheet, Plate	0.05	18.5	9.5	–	–	Si,Ce	Internal shells in bell type furnaces, combustion chambers for the destruction of industrial gases. Off-gas lines and recuperators for temperatures up to about 950°C.
253MA	S30815	Sheet, Plate, Bar, Tube & Pipe.	0.09	21	11	–	–	Si,Ce	Sintering plants, blast furnace plants, steel melting, heating furnaces, heat treatment furnaces, mineral preparation and cement production. Scaling temperature 1150°C.
353MA	s35315	Sheet, Plate	0.05	25	35	–	–	Si,Ce	Cement, gasification, iron and steel, power generation industries, heat treatment and thermal destruction plants. High scaling temperature approximately 1175°C.

COMMON FERRITIC STAINLESS STEEL GRADES

COMMON NAME	UNS #	FORMS AVAILABLE	C	Cr	Ni	Mo	Ti	OTHER	TYPICAL APPLICATIONS
409	S40900	Sheet & Coil	0.02	11.5	–	–	0.25	–	Heat resistant steel, easily formed and welded. Mainly used for automotive exhausts or welded applications where superior performance to galvanised steel is required.
446	S44600	Tube & Pipe	0.08	26	–	–	–	–	Used for severe heat resistant applications up to 1200°C. In recuperators, highly resistant to sulphidation and oil ash corrosion.
430	S43000	Sheet, Coil, Plate & Bars	0.06	17	–	–	–	–	Interior architectural component, stove and automotive trim. Welds tend to be brittle.
444	S44400	Sheet & Coil	0.02	18.5	–	2	0.4	–	Heat exchanger and hot water tanks and in chloride containing waters. Not prone to chloride stress corrosion – superior resistance to pitting, crevice and intergranular corrosion. Possesses excellent deep drawing properties.
3CR12 (1.4003)	S41050	Sheet/Plate & Pipe	0.02	11.5	0.4	–	–	–	Good corrosion resistance and readily weldable it provides a cost effective choice for many structural applications where mild or low alloyed steels require regular repair or replacement.

COMMON MARTENSITIC STAINLESS STEEL GRADES

COMMON NAME	UNS #	FORMS AVAILABLE	C	Cr	Ni	Mo	Ti	OTHER	TYPICAL APPLICATIONS
410	S41000	Bars	0.1	12.5	–	–	–	–	General purpose grade for use in mildly corrosive environments.
416	S41600	Bars	0.1	12.5	–	–	–	0.20S	Free machining variation of 410.
420	S42000	Bars	0.25	12.5	–	–	–	–	General engineering uses, such as pump and valve shafts.
420C	–	Sheet, Coil, Plate & Bars	0.3	12.5	–	–	–	–	Developed for high hardness after heat treatment. Used for cutting tools, surgical knives, etc.
431	S43100	Bars	0.18	16	2	–	–	–	Hardenable steel with corrosion resistance approaching 302. Used for pump shafts etc. Should be double tempered after hardening.
440C	S44004	Bars	4.1	17	–	0.4	–	–	Capable of being hardened to 60 Rc. Highest hardness and abrasion resistance of all the stainless steels. Corrosion resistance similar to 410.

DUPLEX GRADES

COMMON NAME	UNS #	FORMS AVAILABLE	C	Cr	Ni	Mo	Ti	OTHER	TYPICAL APPLICATIONS
2101	S32101	Sheet, Plate, Bar, Tube, Pipe	0.03	21	1.5	0.3	–	0.22N 5Mn	Low alloyed, general purpose duplex stainless steel. Its high mechanical strength is similar to that of other duplex grades and its good corrosion resistance is on par with that of most standard grades of stainless steel. Building and construction, storage tanks, flood gates.
2304	S32304	Sheet, Plate, Pipe & Fittings	0.03	23	4	–	–	0.1N	Similar corrosion resistance to 316L. Higher yield strength, corrosion and stress corrosion cracking resistance. Used where high corrosion resistance is required in marine, mining, chemical, food and power industries. Particularly useful in nitric acid.
2205	S31803	Plate, Pipe, Bar, Fitting	0.03	22	5.5	3	–	0.14N	Superior corrosion resistance to 316L and 317L, combined with high strength. Excellent stress corrosion and abrasion resistance. Typically used in heat exchangers, gas scrubbers, fans, chemical tanks, flowlines, marine and refinery applications.
2507	S32750	Plate, Pipe, Bar, Fittings	0.03	25	7	4	–	0.3N	Extremely high resistance to corrosion in severe marine, chloride and acid environments. Suitable for heat exchangers, reactors, pipework etc.

STAINLESS STEEL												
	18/8 (304, 304L, 321)			MOLYBDENUM (316, 316L)			DUPLEX (-2205)			3CR12 (1.4003)		
TEMPERATURE °C	20°	60°	100°	20°	60°	100°	20°	60°	100°	20°	60°	100°
Aldehydes	R1	R1	R1	R1	R1	R1	R1	R1	R1	R1	R1	R1
Acetic Acid (10%)	R	R	R	R	R	R	R	R	R1	R	R	ND
Acetic Acid (glac. & anh.)	R	R	NR	R	R	R	R	R	NR	ND	ND	ND
Acetic anhydride	R2	NR	NR	R	R	NR	R	R	R1	R2	NR	ND
Ketones	R	R	R	R	R	R	R	R	R	R1	R	ND
Acetylene	R	R	R	R	R	R	R	R	R	R	ND	ND
Acid Fumes	R3	R3	R3	R3	R3	R3	R4	NR	NR	NR	NR	NR
Alcohols	R	R	R	R	R	R	R	R	R	R	R	R
Aliphatic Esters	R	R	R	R	R	R	R	R	R	R	ND	ND
Alkyl Chlorides	R5	R5	R5	R5	R5	R5	R	R	R	R5	ND	ND
Alum	R	R6	NR	R	R	NR	R	R	NR		ND	
Ammonia	R	R	R	R	R	R	R	R	R	R	R	R
Antimony Trichloride	R5	NR	NR	R5	R5	NR	R	R	NR	NR	NR	NR
Aromatic Solvents	R	R	R	R	R	R	R	R	R	R	R	R
Atmospheric												
Industrial	R7	ND	ND	R	ND	ND	R	ND	ND	R7	ND	ND
Marine	R7	ND	ND	R	ND	ND	R	ND	ND	R7	ND	ND
Rural	R	ND	ND	R	ND	ND	R	ND	ND	R7	ND	ND
Ascorbic Acid	R1	R1	R1	R	R	R	R	R	R	R1	ND	ND
Benzoic Acid	R	R	R	R	R	R	R	R	R	R	R	R
Boric Acid	R	R	R	R	R	R	R	R	R	R	R	R
Brines, saturated	R8	NR	NR	R8	NR	NR	R	R	R	NR	NR	NR
Bromide (K) soln.	R9	NR	NR	R9	R9	R9	R	ND	ND	NR	NR	NR
Bromine (+ aqu.)	NR	NR	NR	NR	NR	NR	NR	NR	NR	NR	NR	NR
Butyl Acetate	R	R	R	R	R	R	R	R	R	R	R	R
Calcium Chloride	NR	NR	NR	R8	NR	NR	R10	R10	R10	NR	NR	NR
Carbon Disulphide	R	R	ND	R	R	ND	R	R	R	R	R	R
Carbonic Acid	R	R	R	R	R	R	R	R	R	R	R9	NR
Carbon Tetrachloride	R	R	R	R	R	R	R	R	R	R	R	R
Caustic Soda & Potash	R	R	R6	R	R	R6	R6	R6	ND	ND	R6	R6
Cellulose Paint	R	R	R	R	R	R	R	R	R	R	R	R
Chlorates of Na, K, Ba	R1	R1	R1	R1	R1	R1	R	R	R	ND	ND	ND
Chlorine, dry	R	R	R	R	R	R	R	R	ND	ND	ND	ND
Chlorine, wet	NR	NR	NR	NR	NR	NR	NR	NR	NR	NR	NR	NR
Chlorides of Na, K, Mg, Ca, Ni, NH4, Al, Sn, Zn	R10	NR	NR	R9	R11	R11	R	R	ND	R5	NR	NR
Chlorosulphonic Acid	NR	NR	NR	NR10	NR	NR	ND	ND	ND	ND	ND	ND
Chromic Acid (80%)	NR	NR	NR	NR	NR	NR	NR	NR	NR	NR	NR	NR
Citric Acid	R6	R6	R6	R	R	R6	R	R	R	NR	NR	NR
Cresylic Acids (50%)	R	R	R	R	R	R	R	R	R	R	R	R

R Indicates that the material is resistant to the named chemical up to the temperature shown, subject to limitations indicated below.

NR Indicates that the material is not recommended.

ND Indicates that no data is available.

- | | |
|--|--|
| <ul style="list-style-type: none"> 1 Not if chlorides present 2 Limited data 3 Depending upon the acid 4 Acid fumes dry, attack may occur if moisture builds up 5 Anhydrous 6 Depending upon concentration 7 May discolour with time 8 In strong solutions only when inhibited 9 Pitting possible in stagnant conditions 10 Possibility of pitting | <ul style="list-style-type: none"> 11 May cause stress corrosion cracking 12 When free of SO₂ 13 May cause contamination of product 14 Dilute hypochlorites can be used to sterilize some stainless steel with extreme care 15 General corrosion may become excessive 16 10% 17 In the absence of impurities 18 Dilute 19 Some attack at high temperatures |
|--|--|

STAINLESS STEEL												
	18/8 (304, 304L, 321)			MOLYBDENUM (316, 316L)			DUPLEX (-2205)			3CR12 (1.4003)		
TEMPERATURE °C	20°	60°	100°	20°	60°	100°	20°	60°	100°	20°	60°	100°
Detergents, synthetic	R	R	R	R	R	R	R	R	R	R	R	R
Emulsifiers (all conc.)	R	R	R	R	R	R	R	R	R	ND	ND	ND
Esters & Ethers	R	R	R	R	R	R	R	R	R	R	R	R
Fatty Acids (>C/6)	R	R	R	R	R	R	R	R	R	R	R	R
Ferric Chloride	NR	NR	NR	NR	NR	NR	NR	NR	NR	NR	NR	NR
Fluorinated Refrigerants, Aerosols, e.g. Freon	R5	R	R	R5	R	R	R	R	R	R5	R	NR
Fluorine, dry	R	ND	ND	R	ND	ND	R	R	ND	ND	ND	ND
Fluorine, wet	NR	NR	NR	R	ND	ND	ND	ND	ND	NR	NR	NR
Formic Acid	R	NR	NR	R	R	ND	R	R	ND	NR	NR	NR
Fruit Juices	R12	R	R	R	R	R	R	R	R	R13	NR	NR
Gelatine	R1	R	R	R1	R	R	R	R	R	R1	R1	ND
Glycols	R	R	R	R	R	R	R	R	R	R	R	R
Hydrobromic Acid (50%)	NR	NR	ND	NR	NR	ND	NR	NR	ND	NR	NR	NR
Hydrochloric Acid (10%)	NR	NR	NR	NR	NR	NR	NR	NR	ND	NR	NR	NR
Hydrochloric Acid (conc.)	NR	NR	NR	NR	NR	NR	NR	NR	ND	NR	NR	NR
Hydrocyanic Acid	R	R	ND	R	R	ND	R	R	ND	R	ND	ND
Hydrofluoric acid	NR	NR	NR	NR	NR	NR	NR	NR	NR	NR	NR	NR
Hydrogen Peroxide (30%)	R	R	R	R	R	R	R	R	R	R	R	ND
Hydrogen Sulphide	R5	R5	R5	R5	R5	R5	R5	R5	R5	R5	R5	R5
Hypochlorite (Na 12 - 14%)	R14	NR	NR	R14	NR	ND	R14	ND	ND	R14	ND	ND
Lactic Acid (100%)	R	NR	NR	R	R	NR	R	R	ND	NR	NR	NR
Lead Acetate	R	R	R	R	R	R	R	R	R	R	R	R6
Lead Perchlorate	R1	R1	R1	R	R1	ND	ND	ND	ND	NR	NR	NR
Lime (CaO)	R	R	R	R	R	R	R	R	R	R	R	R
Manganate, Potassium (K)	R	R	R	R	R	R	R	ND	ND	R6	ND	ND
Meat Juices	R	R	ND	R	R	ND	R	R	R	R7	NR	NR
Mercuric Chloride	NR	NR	NR	NR	NR	NR	R	R	R	NR	NR	NR
Milk and its products	R	R	R	R	R	R	R	R	R	R	NR	NR
Molasses	R	R	R	R	R	R	R	R	R	R	R	R
Monoethanolamine	R	R	R	R	R	R	R	R	R	R	R	R
Naphthalen	R	R	R	R	R	R	R	R	R	R	R	R
Nitrates of Na, K, NH3, Ag	R	R	R	R	R	R	R	R	R	R	R	R
Nitric Acid (<25%)	R	R	R	R	R	R	R	R	R	R	R15	NR
Nitric Acid (50%)	R	R	R	R	R	R	R	R	R	R	R15	NR
Nitric Acid (90%)	R	NR	NR	R	NR	NR	R	NR	ND	R	NR	NR
Nitric Acid, fuming	R	R2	R	R	R2	R	R	NR	NR	ND	ND	ND
Oil, Diesel, Petroleum, Spirits	R	R	R	R	R	R	R	R	ND	R	R	R
Oils, Essential	R	R	R	R	R	R	R	R	R	R	R	R

R Indicates that the material is resistant to the named chemical up to the temperature shown, subject to limitations indicated below.

NR Indicates that the material is not recommended.

ND Indicates that no data is available.

- 1 Not if chlorides present
- 2 Limited data
- 3 Depending upon the acid
- 4 Acid fumes dry, attack may occur if moisture builds up
- 5 Anhydrous
- 6 Depending upon concentration
- 7 May discolour with time
- 8 In strong solutions only when inhibited
- 9 Pitting possible in stagnant conditions
- 10 Possibility of pitting

- 11 May cause stress corrosion cracking
- 12 When free of SO₂
- 13 May cause contamination of product
- 14 Dilute hypochlorites can be used to sterilize some stainless steel with extreme care
- 15 General corrosion may become excessive
- 16 10%
- 17 In the absence of impurities
- 18 Dilute
- 19 Some attack at high temperatures

STAINLESS STEEL												
	18/8 (304, 304L, 321)			MOLYBDENUM (316, 316L)			DUPLEX (-2205)			3CR12 (1.4003)		
TEMPERATURE °C	20°	60°	100°	20°	60°	100°	20°	60°	100°	20°	60°	100°
Oil, Lube with aromatic adds	R	R	R	R	R	R	R	R	R	R	R	R
Oils, Vegetable & Animal	R	R	R	R	R	R	R	R	R	R	R	ND
Oxalic Acid	R6	NR	NR	R6	R16	NR	R	R	R	NR	NR	R
Perchloric Acid	NR	NR	NR	NR	NR	NR	NR	NR	NR	NR	NR	R
Phenol	R	R	R	R	R	R	R	R	R	R	R	NR
Phosphoric Acid (20%)	R	R	R	R	R	R	R	R	R	NR	NR	NR
Phosphoric Acid (50%)	R	R	NR	R	R	R	R	R	R	NR	NR	ND
Phosphoric Acid (95%)	R	R	NR	R	R	NR	R17	R17	R17	NR	NR	NR
Phosphorous Pentoxide	R	R	R5	R	R	R5	R	R	R	ND	ND	NR
Pyridine	R	R	R	R	R	R	R	R	R	R	R	NR
Sea Water	R9	NR	NR	R9	NR	NR	R	R	R		NR	
Silicic Acid	R	R	R	R	R	R	R	R	R	R	R	R
Sodium Peroxide	R16	NR	NR	R6	R16	N16	R	R	R	NR	NR	NR
Sodium Silicate	R	R	NR	R	R	NR	R	R	NR	R6	R6	NR
Sodium Sulphide	R	R	R	R	R	R	R	R	R	R	R	NR
Starch	R	R	R	R	R	R	R	R	R	R	R	ND
Sugar, Syrups, Jams	R12	R	R	R	R	R	R	R	R	R12	R12	NR
Sulphamic Acid	R18	NR	NR	R	R19	NR	R	R	NR	NR	NR	ND
Sulphates (Na, K, Mg, Ca,	R	R	R	R	R	R	R	R	R	R	R	R5
Sulphates	R	R	R	R	R	R	R	R	R	NR	NR	ND
Sulphur Dioxide, dry	R	R	R	R	R	R	R	R	R	R	R	NR
Sulphur Dioxide, wet	R	NR	NR	R	R	NR	R	R	NR	NR	NR	R6
Sulphur Dioxide, aqua. Soln. (96%)	R	NR	NR	R	R	R	R	R	R	NR	NR	NR
Sulphur Trioxide	NR	NR	NR	R5	R5	R5	R5	R5	R5	NR	NR	R
Sulphuric Acid (<50%)	NR	NR	NR	R16	NR	NR	R	R	NR	NR	NR	ND
Sulphuric Acid (70%)	NR	NR	NR	NR	NR	NR	R	NR	NR	NR	NR	NR
Sulphuric Acid (95%)	R	NR	NR	R	NR	NR	R	NR	NR	R16	NR	NR
Sulphuric Acid, fuming	R	R2	NR	R	R	NR	R	R	NR	R2	R2	NR
Tannic Acid (10%)	R	R	R	R	R	R	R	R	R	R	R	R
Tartaric Acid	R	R	R	R	R	R	R	R	R	NR	NR	R
Trichlorethylene	R5	R5	R5	R5	R5	R5	R5	R5	R5	R5	R5	R
Urea (30%)	R	R	R	R	R	R	R	R	R	R	R	R
Water, pure	R	R	R	R	R	R	R	R	R	R	R	NR
Yeast	R	R	R	R	R	R	R	R	R	R	R	NR

R Indicates that the material is resistant to the named chemical up to the temperature shown, subject to limitations indicated below.

NR Indicates that the material is not recommended.

ND Indicates that no data is available.

- | | |
|--|--|
| <ul style="list-style-type: none"> 1 Not if chlorides present 2 Limited data 3 Depending upon the acid 4 Acid fumes dry, attack may occur if moisture builds up 5 Anhydrous 6 Depending upon concentration 7 May discolour with time 8 In strong solutions only when inhibited 9 Pitting possible in stagnant conditions 10 Possibility of pitting | <ul style="list-style-type: none"> 11 May cause stress corrosion cracking 12 When free of SO₂ 13 May cause contamination of product 14 Dilute hypochlorites can be used to sterilize some stainless steel with extreme care 15 General corrosion may become excessive 16 10% 17 In the absence of impurities 18 Dilute 19 Some attack at high temperatures |
|--|--|

ANNEAL

A heat treatment to fully soften the material and/or dissolve and take back into equilibrium solution any intermetallic compounds (e.g. carbides) which may have formed within the crystal structure. For most metals and alloys this involves heating to a specified high temperature and subsequently cooling at a slow rate. However, for austenitic stainless steels the subsequent cooling must be rapidly effected.

BEAD ROLLING

Reducing the weld bead practically flush with the wall of the tube. Consists of two contoured rollers slightly forward of the welding head which roll forge the weld whilst the weld area is in the plastic range.

BREAKING DOWN

The first stage in the shaping of an ingot of metal with the object of reducing its section and refining its grain structure.

BRIGHT ANNEALING

Using a furnace with an inert atmosphere no scale is formed and the resulting surface has a bright finish.

CARBIDE

A compound formed when an element combines with carbon. The carbides of metal are usually intensely hard.

CARBIDE PRECIPITATION

A chemical reaction whereby the intermetallic carbides are formed within the crystal structure. They are hard particles which impart hardness and abrasion resisting properties. However, in stainless steels heating to within a high temperature range (450°C - 850°C) causes the formation of chromium carbide. This takes place preferentially at the grain boundaries. A small amount of carbon locks up a large amount of chromium. The material is thus "sensitised". The chromium depleted grain boundaries are therefore prone to suffer preferential and accelerated corrosive attack along the grain boundaries (intergranular corrosion).

COLD DRAWING

The process is effected without the metal being first heated to high temperatures. Examples of the process are the drawing of a tube through a die and over a mandrel to reduce its O.D. and/or wall thickness, or drawing wire through successive dies in series to reduce its diameter.

COLD DRAWN WELDED

Producing a cold drawn tube from a welded hollow. The resulting tube is considered superior to a commercial seamless tube particularly in accuracy and finish.

COLD REDUCING

Feeding a hollow supported in the bore by a tapered mandrel through a pair of semi-circular rolls (each provide with a tapered groove), which rocks backwards and forwards along the tube as it is fed forward in steps. This method provides much greater reduction than is possible by cold drawing.

CREEP

The slow and continuous deformation of a metal at high temperatures. The deformation (strain) is dependent on the stress, the temperature and time. At high temperatures creep can occur at very low levels of stress, less than 10 MPa.

CRYOGENIC TEMPERATURES

These are very low temperatures. The temperatures of liquid gases (e.g. down to 196°C below freezing) are examples of cryogenic temperatures.

CRYSTAL STRUCTURE

Metals are crystalline solids. The atoms of the constituent elements arrange themselves in regular patterns, i.e. the crystal structure, which is repeated many millions of times within any one grain of solidified metal. The direction/orientation of the crystal structure changes at the grain boundary. Iron, steel and stainless steel are three of the few types of metals which exhibit a change of crystal structure. Stainless steels are classified according to their inherent crystal structure which results both from their chemical composition and thermal treatment, viz ferritic, austenitic and martensitic stainless steel.

DEFORMATION

Straining of a metal to such a degree that the change of dimension is permanent.

DUCTILITY

The property of a metal to deform in a plastic manner (i.e. undergo permanent strain) without fracturing. Elongation and reduction of area (RA) are reported properties which give an indication of the ductility.

ECCENTRICITY

A lack of coincidence of the centre of the bore of the tube with that of the outside circumference.

ELECTROPOLISHING

A process whereby the metal surface is actually corroded away under very carefully controlled electrolytic conditions. A smoothing and levelling of the surface takes place. Burrs are also removed from any rough edges. The surface of the electropolished stainless steel has a high degree of reflectivity and the passive film produced on the surface is superior (more corrosion resistant) owing to the formation of the oxygen gas at the surface during the process.

EXTRUSION

A process which confers a given shape on the cross section of a length of metal by pushing the metal, in the solid but plastic state, through a die.

FATIGUE

If metals are subjected to repeated fluctuating (reversing) loads at stresses below the tensile strength, a fatigue crack can initiate in the material which, with increasing number of loading cycles, propagates through the material until final failure by fracture of the metal remaining occurs. Fatigue is an inter-relationship between stress and the number of load cycles, the lower the stress the greater the number of cycles that can be tolerated (in some metals a stress below a certain limiting stress value will never induce fatigue). Failure by fatigue is very sensitive to any surface defects or imperfections which radically lower the fatigue resistance.

FIBRE STRESS

Local stress at a point or line on a section over which stress is not uniform, such as on the cross section of a beam under a bending load or the stress set up in the tube wall by an internal pressure in the tube.

FREE MACHINING GRADES

Brought about by the addition of sulphur or selenium, which increase cutting speeds by approximately 75% over the non-free machining stainless steels. Sulphur is preferred for heavy machining because of the large and fairly continuous inclusions. Selenium is better for light work where a good finish is required. In practice the grades with selenium additions are not readily available. "Improved Machinability" stainless steel bars are available with proprietary designations; these are generally in grades 304, 316 and 303. The Improved Machinability 304 and 316 grades offer significantly faster machining speeds, increased tool life and better surface finish compared with their standard grades. They do this without the poor attributes related to toughness, corrosion resistance and weldability of the high sulphur, free machining grades.

GRAIN STRUCTURE

The shape, size and orientation of the grains within a solidified metal.

HARDENABLE

This means that a material can be hardened by heat treatment. (See also Precipitation Hardening.)

HEAT AFFECTED ZONE (HAZ)

This is within the parent metal adjacent to the weld metal (deposit). It is heated through a range of temperatures up to the melting point which occurs at the junction with the weld metal. The actual temperature attained at any point within the HAZ is an interrelated factor of distance from the weld and the amount of heat input. The high temperatures induced cause changes to and within the crystal structure of the parent metal, which in turn affect the mechanical, physical and corrosion properties within the HAZ.

HEAT EXCHANGER

Usually made of a tube bundle containing numerous tubes expanded into tube sheets and placed inside a shell for the purpose of transferring temperatures between liquids, gases or vapours, one of which is passing through the tubes and the other is around the outside diameter of the tubes and inside the shell.

HEAT TREATMENT

Any high temperature treatment of a metal or alloy in order to modify (improve) the mechanical properties, (and sometimes the physical properties).

HOLLOW

A hot finished tube produced by the extrusion or piercing process for subsequent reduction into cold finished tubing.

HOT SHORTNESS

An undesirable property of certain metals and alloys whereby they are brittle in some elevated temperature ranges.

HYDROSTATIC TEST

The testing of a vessel or pipe with a liquid, usually water, under specified test pressure to prove the tightness of the product. Sometimes used to determine bursting pressure.

INCLUSION

A non-metallic particle (e.g. slag, refractory, oxide or other compound) which has been entrapped in the metal (usually whilst in its molten state) during manufacture.

INTERGRANULAR CORROSION

Preferential corrosion along the grain boundaries. In stainless steels this can result from carbide precipitation (sensitisation), and if it occurs within the heat affected zone (HAZ) adjacent to a weld it is termed "weld decay". This can be prevented by the use of "L" or stabilised grades of austenitic stainless steel.

MANDREL

A smooth cylindrical or conical shaped core or die, around which metal may be formed, drawn or pierced.

MECHANICAL PROPERTIES

A measure of the metal's response to an applied force or load (i.e. stress). The commonly reported mechanical properties include yield strength, tensile strength, elongation, reduction of area (RA), hardness, toughness (Charpy V) and fatigue.

NOMINAL BORE

A term used only to describe a pipe size, not to be confused with an actual internal diameter.

NON DESTRUCTIVE TEST

A method of detecting sub surface as well as any surface (I.D. or O.D.) or other defects without destroying the product. Methods are eddy current, ultrasonic etc.

OVALITY

Out of roundness or difference between maximum and minimum dimensions of outside diameter.

OXIDE FILM

A combination of the oxygen from the atmosphere (or from oxygen in water solutions) with the metal. For most metals this is a natural attack (i.e. corrosion) which reverts metals to the state in which they occur in nature (e.g. rust on steel). High temperature oxidation is termed "scaling".

PASSIVE FILM

Chromium contents in excess of 10.5% Cr in stainless steels result in the formation of a chromium oxide passive film on the surface, provided there is a sufficient availability of oxygen for its formation. This passive film is extremely thin, continuous, tenacious, stable and self-repairable. It renders the surface inert to many chemical reactions and therefore passive. This is stainless steel's natural, built-in corrosion resistance.

PASSIVATION

The treatment of the surface of stainless steels with dilute solutions (or pastes) of nitric acid HNO₃. This, being an oxidising acid, promotes the formation and improves the integrity of the passive film on any freshly treated surface (e.g. through grinding, machining or mechanical damage). The acid treatment also has the secondary beneficial effect of dissolving any free iron or steel contamination which may have been picked up during handling, forming or fabrication operations, and if this were not removed would impair the corrosion resistance. Nitric acid is the only acid which should be used to effect passivation of stainless steel.

PASSIVITY

A state in which a metal or alloy exhibits very low chemical reactivity and is therefore inert in many corrosive media. Chromium imparts passivity to stainless steels due to the formation of the chromium oxide passive film.

PHYSICAL PROPERTIES

Defined as the properties other than mechanical that pertain to the physics of a material, e.g. density, electrical conductivity, heat conductivity and thermal expansion.

PICKLING

The removal of the oxide film from the surface of a metal by chemical means. Exposure to high temperature (e.g. during welding or heat treatment) will scale the surface. In the case of stainless steel such high temperature scale has inferior corrosion resistance and must be removed. Pickling, using formulations of hydrofluoric (HF) and nitric (HNO₃) acids, removes the scale and restores

the corrosion resistance. For application in aggressive environments it is advisable to develop full corrosion resistance by a passivation treatment subsequent to the pickling operation.

PIERCING

Producing a hole in a billet by forcing a pointed mandrel through the hot metal while rolls revolve around the billet externally.

PIPES

As related to ingots, a cavity resulting during cooling of a large mass of metal, caused by contraction.

PRECIPITATION HARDENING

A heat treatment which accelerates the precipitation of micro constituents which contribute to significantly increased strength and hardness.

PROOF STRENGTH

A stress which corresponds to a definite amount of permanent extension is called proof stress. For design purposes 0.2% proof stress is used.

QUENCHING

The rapid cooling (at the required rate) from high temperatures to develop the properties of strength and hardness of hardenable alloys. Quenching rates increase in the following order; still air, air draughts, oils, water, brine solutions

RECRYSTALLISATION

A modification or change in crystalline structure in a cold worked metal, that occurs upon heating through a recrystallisation temperature range.

SHIELDED ARC

Means that the arc used to effect welding is shielded by a gaseous shroud. This protects the metal droplets being transferred through the arc and the molten weld pool from oxidation. The gas shroud is created whether by the components of the flux on covered electrodes in shielded metal arc welding (SMAW) - also referred to as manual metal arc (MMA) - or by the use of inert gases (e.g. argon) in metal inert gas (MIG) and tungsten inert gas (TIG) welding.

SINK DRAWING

A method of reducing the outside diameter only by drawing a tube through a die without supporting plug or mandrel.

SLIDABILITY

This is a surface property which refers to the ease with which material will flow or move over the surface. Good slidability means that flow will take place without sticking or hang-up at low angles of inclination. Stainless steels possess good slidability properties.

SOLID SOLUTION

A crystalline structure in which the atoms of the component are intimately mixed (i.e. in complete solution with each other). Under the microscope only one constituent will be seen. Solid solutions, in virtually all cases, freeze or melt over a temperature range as distance from a fixed and specific temperature for pure metals.

SOLUTION TREATMENT

A heat treatment which effects the solution of intermetallic compounds or precipitates (e.g. carbides) at high temperatures. Subsequent cooling must be fast enough to prevent their reformation during the cooling cycle.

STABILISED

This refers to the alloying of titanium (Ti) or niobium (Nb) to the austenitic grades. These elements form stable carbides, thereby locking up the carbon and preventing the formation of chromium carbides. Prevents sensitisation and intergranular corrosion (weld decay) in the region next to the weld in welded components of thicker material ($>=2.5\text{mm}$).

STRAIN

This is the measure of the change of dimensions resulting from an applied stress (load or force), and is calculated by increase in dimensions divided by original dimensions. Up to a relatively low value of stress the strain is elastic (i.e. if the stress is removed the material returns to its original dimensions). Strain has no units, but is normally expressed as a percentage.

STRESS

The measure of applied load (force) per unit area. Common units of stress are Mpa ($=1\text{ N/mm}^2$), tons/in², lbs/in², and kg/mm².

STRESS CORROSION CRACKING

SCC may occur in susceptible materials if they are exposed to three co-existing factors. In the case of stainless steel, the austenitic grades are those which usually suffer from this form of corrosion in applications which involve a tensile stress (residual or applied), higher than normal ambient temperatures (usually above approximately 60°C) and the presence of an insidious (aggressive) ion (usually the chloride Cl-ion). The higher the values of these respective factors the greater the danger of SCC. The initiation of SCC is similar to pitting and may take considerable time. Once initiated the tensile strength causes mechanical failure (cracking) at the root of the pit, and this then normally progresses rapidly to cause final failure.

TEMPERING

Quenched materials are hard and strong, but extremely brittle and of low ductility. Tempering should immediately follow quenching, and be effected at a temperature necessary to increase the toughness and ductility.

This will usually incur a loss of hardness and strength, more so of higher tempering temperatures are used. The tempering temperature is chosen to bring about the correct desired combination of properties. The maximum tempering temperature is below that at which a change of crystal structure will be induced.

TEMPERS

Used to define the levels to which austenitic stainless steels are strengthened by cold rolling or cold drawing, without any subsequent annealing operation. Cold rolled sheet, coil and strip are produced to 1/4, 1/2, 3/4 and full hard tempers; wire is produced to annealed, soft, intermediate and spring tempers.

TENSILE STRENGTH

The value of the maximum stress in tension that a material will withstand. The units are the same as those for "stress" above.

TOUGHNESS

This is the capacity of a metal or alloy to yield in a plastic manner under conditions of highly localised stress induced by shock loads. Tough materials yield plastically and absorb a lot of energy. Whereas brittle materials (converse to tough) fracture rather than yield plastically and absorb little energy.

WELDABILITY

This is not an exactly quantifiable or precise property, but rather implies the ability of the material to be joined by standard welding processes so that the resultant mechanical, physical and chemical properties of the weld zone (i.e. both the weld metal and the HAZ) are at least equivalent to those of the parent metal.

WORK HARDENING

Most metals and alloys will exhibit a slight degree of increase in both strength and hardness if subjected to cold work (e.g. cold rolling, cold drawing, cold bending etc). The austenitic stainless steels show a marked response to work hardening and are therefore termed "hardenable by cold work" or "work hardenable" materials.

YIELD STRENGTH

At a stress below the tensile strength the material reaches a point at which permanent strain (deformation) occurs. In some steels there is a marked increase of strain for no increase in stress i.e. yield point. If this does not occur (as in austenitic grades of stainless steel) a stress value for a specified amount of strain (usually 0.2%) is taken. The stress at the yield point or at 0.2% strain is reported as the yield strength. The units are the same as for "stress" above.

MidwayMetals

COIL CENTRE
ALBURY
BRISBANE
MELBOURNE
NEWCASTLE
PERTH
SYDNEY
TOWNSVILLE
AUCKLAND
VIETNAM

P (07) 3382 9500
P (02) 6041 4000
P (07) 3287 2811
P (03) 9791 5111
P (02) 4966 3800
P (08) 9248 6944
P (02) 9670 8900
P (07) 4728 8777
P +64 9 424 4194
P +84 3 5138 48468

F (07) 3807 8150
F (02) 6041 4422
F (07) 3807 2687
F (03) 9791 5333
F (02) 4966 3811
F (08) 9248 6955
F (02) 9834 2441
F (07) 4728 8778
F +64 9 424 4194
F +84 3 5138 48456

headoffice@midwaymetals.com.au
albury@midwaymetals.com.au
brisbane@midwaymetals.com.au
melbourne@midwaymetals.com.au
newcastle@midwaymetals.com.au
perth@midwaymetals.com.au
sydney@midwaymetals.com.au
townsville@midwaymetals.com.au
auckland@midwaymetals.com.au
info@midwaymetals.com.vn