

NEXT EVO INV: Close control air conditioners, equipped with BLDC inverter scroll compressors.

Cooling Capacity: 7,3 ÷ 102,0 kW



next
rcgroupairconditioning



MAIN FEATURES

- Direct expansion precision air conditioner.
- 13 models available, 2 versions for a wide selection opportunity.
- Modulating cooling capacity control.
- EER up to 4,74.
- BLCD inverter and on/off scroll compressors.
- Single and double refrigerant circuit.
- R410A Refrigerant charge.
- EC plug-fans.
- OVER and UNDER versions.
- Suitable for indoor installation.

MAIN BENEFITS

- Units with single and double refrigerant circuits.
- Availability of remote condensers with axial fans (TEAM MATE series) and with plug fans (TEAM MATE PF series).
- High EER.
- High efficiency at partial load.
- Availability of electric heater.
- Availability of steam humidifier.
- Availability of hot water heating coil.
- Availability of extra circuit heating coil.
- Complete set of optional accessories: filters, plenum, panels, stand.
- Easily of maintenance.

INDOOR INSTALLATION

The machines are designed for indoor installation.

REMOTE CONDENSER

The units are designed to be matched with remote condensers with axial fans (TEAM MATE series) or plug-fans (TEAM MATE PF series).

WORKING LIMITS

Room air temperature:

14°C	minimum temperature with wet bulb.
24°C	maximum temperature with wet bulb.
35°C	maximum temperature with dry bulb.

Room air humidity:

20%RH	minimum relative humidity.
75%RH	maximum relative humidity.

MAIN COMPONENTS

FRAMEWORK

- Base in aluminium extrusion, painted with epoxy powders.
- Frame in galvanized steel sheet.
- Galvanized steel sheet panels painted with epoxy powders, internally insulated with noise absorption material and seals to ensure air tight with the panels.
Hinged front panels with quick release removal system.
Total front access for routine maintenance.
Removable lateral and back side panels.
- Colour: RAL 9005 for base and frame (black)
RAL7016 for panels (anthracite gray)
- OVER version
 - Air intake from the front through honeycomb type grille and air delivery from the top.
 - Washable air pre-filters with G2 efficiency, with cells in synthetic fibre (size E0 excluded).
- UNDER version
Machine size E0
 - Air intake from the front through honeycomb type grille and air delivery from the bottom.
- Machine size E1, E2, E3, E4, E5, E6, E7, E8, E9
 - Air intake from the top and air delivery from the bottom.

INVERTER DRIVEN COMPRESSORS

- scroll compressor BLDC inverter with spiral profile optimized for R410A refrigerant.
- Synchronous brushless inverter driven motor.
- Inverter for modulating capacity control.
- Reactance for the reduction of electromagnetic noise and interference.
- Crankcase heater.
- Rubber supports.
- Soundproof cap.

ON / OFF COMPRESSORS

- scroll compressors with spiral profile optimized for R410A refrigerant.
- 2-pole 3-phase electric motor with direct on line starting.
- Crankcase heater.
- Rubber supports.
- Soundproof cap.

FILTER SECTION

- Machine size E0
Washable air filters with G2 efficiency, with cells in synthetic fibre and metallic frame (EN 779-2002).
- Machines size E1, E2, E3, E4, E5, E6, E7, E8, E9
Washable air filters with G4 efficiency, with cells in synthetic fibre and metallic frame (EN 779-2002).

EVAPORATING SECTION

- Heat exchanger coil with internally corrugated copper tubes and high efficiency aluminium fins, specifically developed to provide high heat transfer and lower pressure drops.
- Finned pack with hydrophilic treatment that assure the condensate water drop, high thermal conductivity and does not favour the growth of micro-organisms.
- Frame in galvanized steel.
- Condensate tray in peraluman with PVC flexible discharge pipe.

FANS SECTION

- Centrifugal fans with backward curved blades with wing profile, single suction and without scroll housings (Plug-fans), directly coupled to external rotor electric motor.
 - Impeller in composite material, PA6 plastic reinforced with glass-fibre, exempt from rust formation.
 - Brushless type synchronous EC motor with integrated electronic commutated system and continuous variation of the rotation speed. The motor rotation control is obtained with the EC system (Electronic Commutation) that manage the motor according to the signal coming from the microprocessor control.
- Fans control through ModBus.
- Temperature sensors on air intake and air delivery with control, regulation and limitation functions.
- Fan guard with rubber support (UNDER version)

REFRIGERANT CIRCUIT

Components for each refrigerant circuit:

- Electronic expansion valve.
- Sight glass.
- Filter dryer on liquid line.
- Pressure transducers with indication, control and protection functions, on low and high refrigerant pressure.
- High pressure safety switch with manual reset.
- Liquid receiver with accessories.
- Refrigerant circuit with copper tubing with anticondensate insulation of the suction line.
 - Plastic capillary hoses for pressure sensors connection.
 - R410A refrigerant charge and lubricant oil type PVE (Polyvinyl ether).
 - Valves on gas delivery and liquid return for coupling to remote air cooled condenser.
- 0÷10V proportional signal to manage the condensing control system of the remote air cooled condenser.
- Oil separator on gas discharge.

ELECTRICAL PANEL

In accordance with EN60204-1 norms complete with:

- Main switch with door lock safety.
- Magnetothermic switches for fans.
- Magnetothermic switches for compressors.
- Contactors for each load. The inverter driven compressors and the EC fans don't require contactors.
- Transformer for auxiliary circuit and microprocessor supply.
- Terminals:

OUTLETS

- Voltage free deviating contact for General Alarm 1
- Voltage free contact for machine operating status.

INLETS

- Emergency unit stop with signalling on display (external alarm).
- External enabling.
- Power supply 400/3/50+N

CONTROL SYSTEM

- Microprocessor system with graphic display for control and monitor of operating and alarms status. The system includes:
 - Real time clock.
 - Predisposition for connectivity board housing (RCom MBUS/JBUS, LON, BACnet for Ethernet (SNMP- TCP/IP), BACnet for MS/TP).
 - Main components hour-meter.
 - Nonvolatile "Flash" memory for data storage in case of power supply faulty and for alarms status recording (2MB).
 - Menu with protection password.
 - LAN connection.

COMMON OPTIONAL ACCESSORIES

NEXT EVO INV	007	010	016	020	028	034	040	053	057	040	065	080	100
SIZE	S M1	S M1	S M1	S M1	S M1	S M2	S M2	S M3	S M3	D M11	D M11	D M22	D M22
	E0	E1	E2	E3	E4	E4	E5	E5	E6	E5	E7	E8	E9
TEAM MATE remote condenser	•	•	•	•	•	•	•	•	•	•	•	•	•
TEAM MATE PF remote condenser	•	•	•	•	•	•	•	•	•	•	•	•	•
213 - Team Mate electrical power supply by internal unit	-	-	-	-	•	•	•	•	•	-	-	-	-
848 - Condensate discharge system (kit)	•	•	•	•	-	-	-	-	-	-	-	-	-
849 - Condensate discharge system	-	-	-	-	•	•	•	•	•	•	•	•	•
405 - Extra-Circuit system	-	•	•	•	•	•	•	•	•	•	•	•	•
810 - Floor stand Hmax=350 mm	•	•	•	•	•	•	•	•	•	•	•	•	•
811 - Floor stand Hmax=450 mm	•	•	•	•	•	•	•	•	•	•	•	•	•
812 - Floor stand Hmax=510 mm	•	•	•	•	•	•	•	•	•	•	•	•	•
808 - Sandwich panels	•	•	•	•	•	•	•	•	•	•	•	•	•
843 - Motorized damper with frame	-	•	•	•	•	•	•	•	•	•	•	•	•
832 - Air supply plenum with F6 filters	-	•	•	•	•	•	•	•	•	•	•	•	•
833 - Air supply plenum with F7 filters	-	•	•	•	•	•	•	•	•	•	•	•	•
835 - Air supply plenum with F9 filters	-	•	•	•	•	•	•	•	•	•	•	•	•
836 - Air supply plenum with sound absorber	-	•	•	•	•	•	•	•	•	•	•	•	•
945 - Air return plenum with Free Cooling damper	-	•	•	•	•	•	•	•	•	•	•	•	•
321 - Steam humidifier	•	•	•	•	•	•	•	•	•	•	•	•	•
773 - Dehumidification system	•	•	•	•	•	•	•	•	•	•	•	•	•
310 - Electric heater	•	•	•	•	•	•	•	•	•	•	•	•	•
514 - Water heater + 2 way valve	•	•	•	•	•	•	•	•	•	•	•	•	•
508 - Automatic S/W operation	•	•	•	•	•	•	•	•	•	•	•	•	•
606 - Compr. power factor capacitor - 0,9	•	•	•	•	•	•	•	•	•	•	•	•	•
81 - Phases sequence control relay	•	•	•	•	•	•	•	•	•	•	•	•	•
204 - Pressure control under the raised floor.	•	•	•	•	•	•	•	•	•	•	•	•	•
215 - Disposal F5 efficiency air filter	-	•	•	•	•	•	•	•	•	•	•	•	•
909 - Clogged filters alarm	•	•	•	•	•	•	•	•	•	•	•	•	•
911 - Water presence alarm	•	•	•	•	•	•	•	•	•	•	•	•	•
913 - Additional water sensor (kit)	•	•	•	•	•	•	•	•	•	•	•	•	•
860 - T/rH sensor on air return	•	•	•	•	•	•	•	•	•	•	•	•	•
866 - T/rH external sensor	•	•	•	•	•	•	•	•	•	•	•	•	•
867 - T/rH remote sensor	•	•	•	•	•	•	•	•	•	•	•	•	•
863 - Remote terminal shared	•	•	•	•	•	•	•	•	•	•	•	•	•
923 - RC-Com MBUS/JBUS Serial board	•	•	•	•	•	•	•	•	•	•	•	•	•
926 - LON Serial board	•	•	•	•	•	•	•	•	•	•	•	•	•
931 - BACnet Ethernet - SNMP - TCP/IP Serial board	•	•	•	•	•	•	•	•	•	•	•	•	•
932 - BACnet MS/TP Serial board	•	•	•	•	•	•	•	•	•	•	•	•	•
MBUS RS485/JBUS + BACnet for Ethernet - SNMP - TCP/IP double serial board	•	•	•	•	•	•	•	•	•	•	•	•	•
MBUS RS485/JBUS + BACnet per MS/TP double serial board	•	•	•	•	•	•	•	•	•	•	•	•	•
958 - Temporary power microprocessor	•	•	•	•	•	•	•	•	•	•	•	•	•
962 - Kit modem GSM	•	•	•	•	•	•	•	•	•	•	•	•	•
957 - Plantwatch without modem	•	•	•	•	•	•	•	•	•	•	•	•	•
930 - Remote graphic terminal kit	•	•	•	•	•	•	•	•	•	•	•	•	•

• available accessory; - not available accessory

OPTIONAL ACCESSORIES - OVER VERSION ONLY

NEXT EVO INV	007	010	016	020	028	034	040	053	057	040	065	080	100
SIZE	S M1	S M1	S M1	S M1	S M1	S M2	S M2	S M3	S M3	D M11	D M11	D M22	D M22
	E0	E1	E2	E3	E4	E4	E5	E5	E6	E5	E7	E8	E9
862 - Acoustic panel	-	•	•	•	•	•	•	•	•	•	•	•	•
830 - Air discharge plenum with grilles	•	•	•	•	•	•	•	•	•	•	•	•	•
831 - Plenum with frontal grille and sound absorber	-	•	•	•	•	•	•	•	•	•	•	•	•
807 - Blind frontal panel	-	•	•	•	•	•	•	•	•	•	•	•	•

• available accessory; - not available accessory

TO BE MATCHED WITH REMOTE CONDENSER

The units are designed to be matched with remote condensers with axial fans (TEAM MATE series) or plug-fans (TEAM MATE PF series).



TEAM MATE
pg:145



TEAM MATE PF
pg:149

AN EFFICIENT ENERGY USE

The project NEXT EVO INV uses the current best technologies aimed at energy saving for an extremely efficient use of energy as scroll compressors BLDC inverter and EC supply fans. In detail:

COOLING SECTION

Units are equipped with scroll compressors BLDC inverter that allow a modulating cooling capacity.

The scroll compressor BLDC Inverter can change the load continuously and the regulation of the refrigerant circuit can be easily adapted, without oscillations and transients, to the operating conditions required.

The system is highly efficient because it is supplying only the energy necessary to satisfy the required thermal load; furthermore the system can supply cooling capacity even in case of overload conditions.

Models with double refrigerant circuit (D version) are equipped with one scroll compressor BLDC inverter for each refrigerant circuit. This solution ensures extreme precision in the delivery of the cooling capacity required, together with a drastic reduction of power input from the compressors.

The exchanger finned coils of large surface is provided with fins with hydrophilic treatment that guarantees optimum falling water of condensation, high thermal conductivity and prevents the development of micro-organisms.

Models with double refrigerant circuit (D version) are equipped with interlaced finned coil that maximizes the heat exchange in the operating condition with a single cooling circuit, cancelling the by-pass effect on the exchanger.

FAN SECTION

The Plug fans of the air handling section of the NEXT EVO INV series are directly coupled to brushless type electric motors with built-in electronic commutation system (EC) and driven by microprocessor control via MODBus; this allows a unit operation with variable air flow.

These EC electric motors ensuring high performances, minimum energy consumption and total absence of electromagnetic noise.

The management software of the machine, specifically developed by RC Group for their precision air conditioners, allowing the better management of the system machine with a modulating logic of ventilation, cooling performances and the accessory system of direct free-cooling.

CONTROL LOGIC AND OPERATION

The logic PID of the microprocessor enables simultaneous control of cooling performances as a function of air delivery temperature and the air flow as a function of air return temperature or pressure in the underfloor / duct. Are therefore possible following two control logics

LOGIC 1

Cooling performance control as a function of air delivery temperature and of the air flow as a function of the return temperature.

LOGIC 2

Cooling performance control as a function of the air delivery temperature and the air flow as a function of the underfloor / duct pressure.

Follow the detailed description of the control logic.

CONTROL OF THE COOLING CAPACITY ACCORDING TO AIR DELIVERY TEMPERATURE

The cooling capacity control is made on the air delivery temperature.

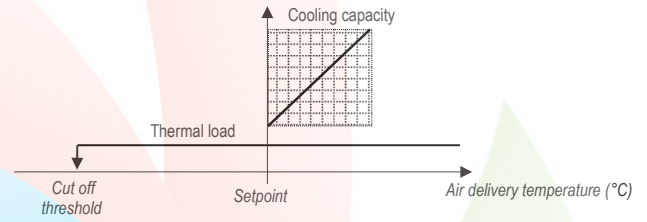

AIR FLOW CONTROL ACCORDING TO AIR RETURN TEMPERATURE

The EC plug fans modulate the air flow using as variable the distance from the temperature set point.

It's possible to define the minimum and maximum air flow through dedicated parameters in order to adjusting the operation of the unit to the needs of the plant.

In addition to the probe positioned on the machine, you can install the accessory remote probe to be placed in the environment to influence the most critical point of the system

In case of no demand of cooling / heating, the control logic provides that the fans ensure a minimum air flow necessary to the probes to obtain a correct reading of the ambient temperature. Moreover in only dehumidification demand condition, the microprocessor control reduce the air flow to obtain the maximum dehumidification effect.

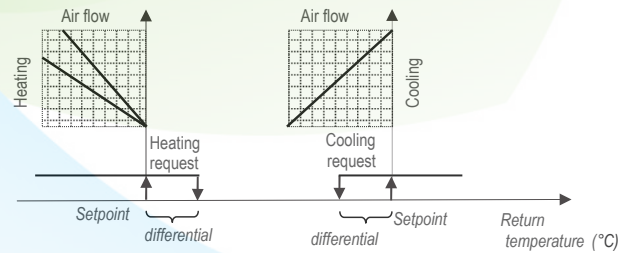

AIR FLOW CONTROL AS FUNCTION OF THE UNDERFLOOR OR DUCTING PRESSURE (optional accessory)

The EC plug fans modulate the air flow using as variable the distance of a signal from the set point, coming from a differential pressure transmitter (optional) with pressure outlet via plastic tubing, to install underfloor or in the duct.

It's possible to define the minimum and maximum air flow through dedicated parameters in order to adjusting the operation of the unit to the needs of the plant.

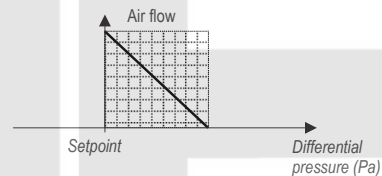

DIRECT FREE-COOLING SYSTEM (optional accessory)

The control system also manages the operation of the air conditioner equipped with a plenum for DIRECT FREE-COOLING (optional), that allows free cooling in the environment to be conditioned, directly entering outdoor air. The accessory is fully modulating and ensures a drastic reduction of power consumption of the machine, avoiding the start of the compressors. The use of this accessory includes the installation of an overpressure damper into the room to allow for the expulsion of excess air.

GRAPHIC FOR UNITS SELECTION

This graph allows you to select the model as a function of cooling capacity and its EER.

The EER values include the remote condenser series TEAM MATE.

Characteristic referred to entering air at 24°C-50%rH; condensing temperature 50°C

SINGLE REFRIGERANT CIRCUIT

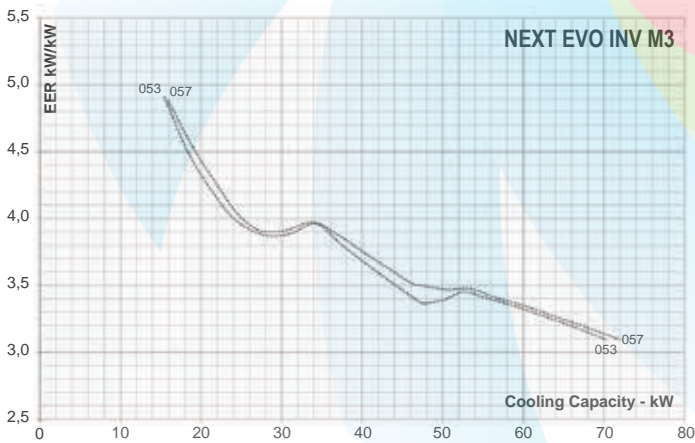
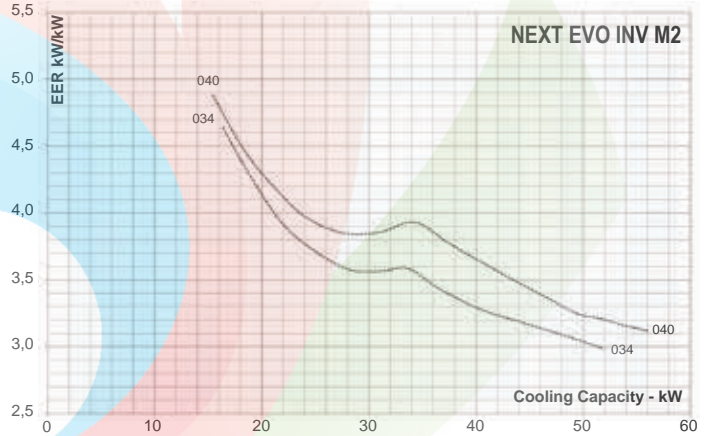
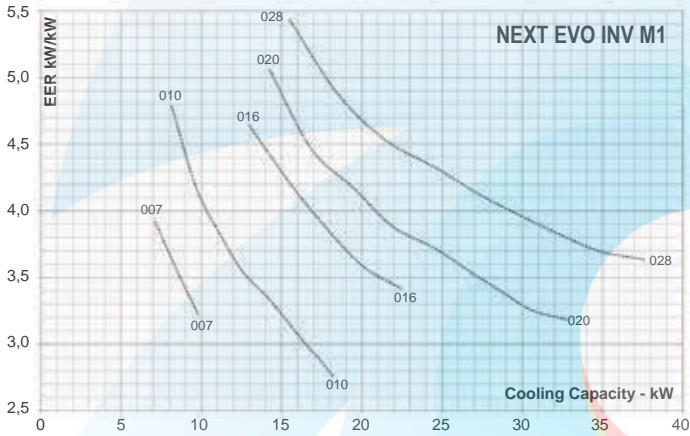

DOUBLE REFRIGERANT CIRCUIT

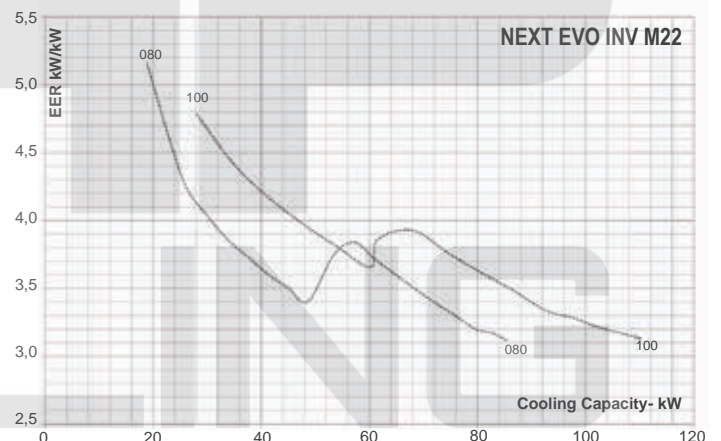
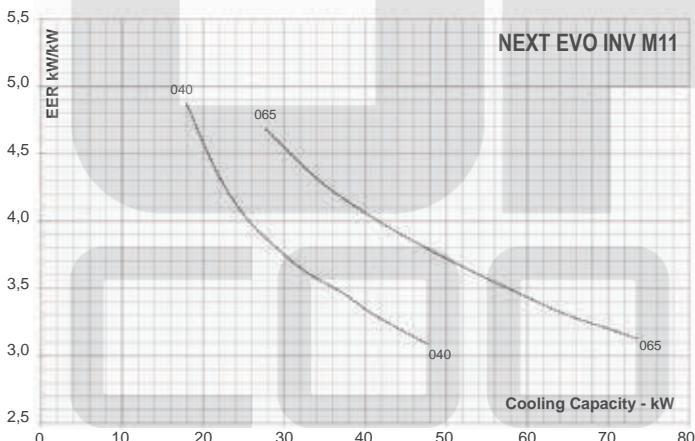

TECHNICAL DATA

MODEL SIZE	007 S M1			010 S M1			016 S M1			020 S M1			
	Min	Nom	Max	Min	Nom	Max	Min	Nom	Max	Min	Nom	Max	
COOLING CAPACITY (1)													
Total	kW	7,30	8,52	9,50	8,73	11,60	17,30	13,50	18,00	21,30	15,20	22,50	31,00
Sensible	kW	6,46	7,03	7,57	8,73	10,30	13,30	13,40	16,40	18,10	15,20	21,30	26,60
SHR	kW/kW	0,88	0,83	0,80	1,00	0,89	0,77	0,99	0,91	0,85	1,00	0,95	0,86
Unit power input Over (*)	kW	1,98	2,69	3,45	2,18	3,45	8,02	3,67	6,00	8,37	3,63	6,74	12,78
Unit power input Under (*)	kW	1,98	2,69	3,45	2,17	3,44	8,01	3,63	5,94	8,31	3,57	6,67	12,71
Supply fans	n.	1	1	1	1	1	1	1	1	1	1	1	1
Air flow	m3/h	1800	1800	1800	2700	2700	2700	4000	4475	4475	5500	6000	6600
Nominal external static pressure Over	Pa	50	50	50	50	50	50	50	50	50	50	50	50
Nominal external static pressure Under	Pa	20	20	20	20	20	20	20	20	20	20	20	20
Fans max external static pressure	Pa	80	80	80	52	52	52	175	175	175	628	628	628
Scroll compressors													
BLCD inverter type	n.		1			1			1			1	
On/Off type	n.		--			--			--			--	
Cooling capacity control			Mod.			Mod.			Mod.			Mod.	
Air filters	n.		1			1			1			2	
Efficiency			G2			G4			G4			G4	
Refrigerant			R410A			R410A			R410A			R410A	
Refrigerant charge (2)	kg		2,5			2,8			3,1			3,7	
Gas circuits	n.		1			1			1			1	
Power supply (**)			400/3/50+N			400/3/50+N			400/3/50+N			400/3/50+N	
Max operating current (FLA) (*)	A		8,03			18,90			12,40			29,98	
Unit starting current (LRA)	A		4,23			5,20			5,70			8,18	
Energy efficiency indexes (1)													
EER (*)	kW/kW	3,69	3,17	2,75	4,00	3,36	2,16	3,68	3,00	2,54	4,19	3,34	2,43
Sound pressure level - ISO 3744 (3)													
On air delivery Over	dB(A)	51,0	51,0	51,0	58,4	58,4	58,4	61,1	63,3	63,3	61,1	62,9	64,9
On air delivery Under	dB(A)	51,0	51,0	51,0	58,2	58,2	58,2	60,6	63,0	63,0	60,8	62,6	64,7
On air intake Over	dB(A)	45,1	45,1	45,1	47,3	47,3	47,3	49,5	51,1	51,1	49,5	50,8	52,3
Irradiated Over	dB(A)	35,0	35,0	35,0	40,3	40,3	40,3	43,0	45,2	45,2	43,0	44,8	46,8
On air intake Under	dB(A)	45,1	45,1	45,1	49,9	49,9	49,9	52,3	54,5	54,5	52,4	54,2	56,1
On front side Under	dB(A)	35,0	35,0	35,0	40,5	40,5	40,5	42,9	45,1	45,1	43,0	44,8	46,7
Net weight Over	kg		170			230			270			310	
Net weight Under	kg		180			240			280			330	
Remote condenser (4)													
TEAM MATE	n. x Mod.		1xM11			1xM20			1xM25			1xM35	
Refrigerant connections													
Gas delivery	ODS Ø		12			12			16			16	
Liquid return	ODS Ø		12			12			12			16	

MODEL SIZE	028 S M1			034 S M2			040 S M2			053 S M3			
	Min	Nom	Max	Min	Nom	Max	Min	Nom	Max	Min	Nom	Max	
COOLING CAPACITY (1)													
Total	kW	16,70	28,10	37,00	16,90	35,00	50,20	16,80	40,80	52,90	17,00	54,20	69,10
Sensible	kW	16,70	28,10	37,00	16,90	35,00	45,50	16,80	40,80	52,70	17,00	53,00	60,30
SHR	kW/kW	1,00	1,00	1,00	1,00	1,00	0,91	1,00	1,00	1,00	1,00	0,98	0,87
Unit power input Over (*)	kW	3,80	8,18	13,74	4,03	9,96	19,54	3,71	11,94	20,22	4,13	15,93	24,43
Unit power input Under (*)	kW	3,64	7,94	13,35	3,87	9,64	19,15	3,63	11,81	20,06	4,05	15,77	24,27
Supply fans	n.	1	1	1	1	1	1	2	2	2	2	2	2
Air flow	m3/h	7500	9500	12200	7500	11000	12200	6500	12500	15500	6500	15500	15500
Nominal external static pressure Over	Pa	50	50	50	50	50	50	50	50	50	50	50	50
Nominal external static pressure Under	Pa	20	20	20	20	20	20	20	20	20	20	20	20
Fans max external static pressure	Pa	131	131	131	258	258	258	775	775	775	520	520	520
Scroll compressors													
BLCD inverter type	n.		1			1			1			1	
On/Off type	n.		--			1			1			2	
Cooling capacity control			Mod.			Mod.			M			M	
Air filters	n.		3			3			3			3	
Efficiency			G4			G4			G4			G4	
Refrigerant			R410A			R410A			R410A			R410A	
Refrigerant charge (2)	kg		4,9			5,2			7,5			7,6	
Gas circuits	n.		1			1			1			1	
Power supply (**)			400/3/50+N			400/3/50+N			400/3/50+N			400/3/50+N	
Max operating current (FLA) (*)	A		30,80			46,00			50,06			65,96	
Unit starting current (LRA)	A		8,30			67,10			71,16			84,26	
Energy efficiency indexes (1)													
EER (*)	kW/kW	4,39	3,44	2,69	4,19	3,51	2,57	4,53	3,42	2,62	4,12	3,40	2,83
Sound pressure level - ISO 3744 (3)													
On air delivery Over	dB(A)	59,4	64,1	69,3	59,4	67,1	69,3	53,0	66,1	70,7	53,0	70,7	70,7
On air delivery Under	dB(A)	57,7	62,8	68,2	57,7	65,9	68,2	52,1	66,0	70,6	52,1	70,6	70,6
On air intake Over	dB(A)	48,5	51,7	56,2	49,6	54,5	56,3	47,8	53,7	57,6	48,7	57,7	57,7
Irradiated Over	dB(A)	41,3	46,0	51,2	41,5	49,0	51,2	37,0	48,0	52,6	37,5	52,6	52,6
On air intake Under	dB(A)	49,7	54,3	59,6	50,0	57,5	59,6	46,3	57,5	62,0	46,8	62,0	62,0
On front side Under	dB(A)	40,3	44,9	50,2	40,7	48,0	50,2	37,2	48,1	52,6	37,7	52,6	52,6
Net weight Over	kg		420			460			540			590	
Net weight Under	kg		430			470			550			600	
Remote condenser (4)													
TEAM MATE	n. x Mod.		1xM45			1xM60			1 x M 60			1 x M 95	
Refrigerant connections													
Gas delivery	ODS Ø		16			18			18			18	
Liquid return	ODS Ø		16			16			18			18	

TECHNICAL DATA

MODEL SIZE		057 S M3 E6			040 D M11 E5			065 D M11 E7			080 D M22 E8		
		Min	Nom	Max	Min	Nom	Max	Min	Nom	Max	Min	Nom	Max
COOLING CAPACITY (1)													
Total	kW	17,70	60,60	71,40	19,00	38,20	42,80	29,60	62,50	69,30	58,50	77,10	81,30
Sensible	kW	17,70	59,70	65,30	19,00	38,20	42,80	28,60	62,50	69,30	58,40	77,10	80,20
SHR	kW/kW	1,00	0,99	0,91	1,00	1,00	1,00	0,97	1,00	1,00	1,00	1,00	0,99
Unit power input Over (*)	kW	4,22	18,39	24,99	4,07	14,29	18,69	6,24	21,80	27,30	15,83	27,55	30,85
Unit power input Under (*)	kW	4,13	18,21	24,81	3,99	14,16	18,54	6,14	21,58	27,07	15,65	27,30	30,60
Supply fans	n.	2	2	2	2	2	2	2	2	2	3	3	3
Air flow	m3/h	8000	18000	18000	6500	12500	14500	8000	20000	21100	17000	24200	24200
Nominal external static pressure Over	Pa	50	50	50	50	50	50	50	50	50	50	50	50
Nominal external static pressure Under	Pa	20	20	20	20	20	20	20	20	20	20	20	20
Fans max external static pressure	Pa	511	511	511	775	775	775	375	375	375	475	475	475
Scroll compressors													
BLCD inverter type	n.		1			2			2			2	
On/Off type	n.		2			--			--			2	
Cooling capacity control			M			M			M			M	
Air filters	n.		4			3			4			5	
Efficiency			G4			G4			G4			G4	
Refrigerant			R410A			R410A			R410A			R410A	
Refrigerant charge (2)	kg		8,2			8,2			10,0			14,0	
Gas circuits	n.		1			2			2			2	
Power supply (**)			400/3/50+N			400/3/50+N			400/3/50+N			400/3/50+N	
Max operating current (FLA) (*)	A		66,46			44,36			64,20			76,94	
Unit starting current (LRA)	A		84,76			14,36			16,60			147,34	
Energy efficiency indexes (1)													
EER (*)	kW/kW	4,19	3,30	2,86	4,67	2,67	2,29	4,74	2,87	2,54	3,70	2,80	2,64
Sound pressure level - ISO 3744 (3)													
On air delivery Over	dB(A)	50,8	67,8	67,8	53,0	66,1	69,3	49,8	67,2	68,3	65,7	73,3	73,3
On air delivery Under	dB(A)	50,3	67,9	67,9	52,1	66,0	69,2	47,8	67,0	68,2	65,6	73,2	73,2
On air intake Over	dB(A)	48,5	55,3	55,3	47,4	53,6	56,3	48,4	54,7	55,7	53,8	60,1	60,1
Irradiated Over	dB(A)	36,7	49,7	49,7	36,7	48,0	51,2	36,4	49,1	50,2	47,6	55,2	55,2
On air intake Under	dB(A)	46,1	59,3	59,3	46,8	57,5	60,6	45,4	58,5	59,6	57,2	64,6	64,6
On front side Under	dB(A)	37,0	49,9	49,9	37,7	48,1	51,2	36,4	49,1	50,2	47,8	55,1	55,1
Net weight Over	kg		630			565			650			835	
Net weight Under	kg		640			575			705			895	
Remote condenser (4)													
TEAM MATE	n. x Mod.		1 x M 95			2 x M 20			2 x M 35			2 x M 45	
Refrigerant connections													
Gas delivery	ODS Ø		18			16			18			22	
Liquid return	ODS Ø		18			12			16			18	

MODEL SIZE		100 D M22 E9		
		Min	Nom	Max
COOLING CAPACITY (1)				
Total	kW	69,50	96,80	102,00
Sensible	kW	68,00	96,10	99,50
SHR	kW/kW	0,98	0,99	0,98
Unit power input Over (*)	kW	18,82	36,22	41,32
Unit power input Under (*)	kW	18,61	35,93	41,03
Supply fans	n.	3	3	3
Air flow	m3/h	20000	28680	28680
Nominal external static pressure Over	Pa	50	50	50
Nominal external static pressure Under	Pa	20	20	20
Fans max external static pressure	Pa	450	450	450
Scroll compressors				
BLCD inverter type	n.		2	
On/Off type	n.		2	
Cooling capacity control			M	
Air filters	n.		6	
Efficiency			G4	
Refrigerant			R410A	
Refrigerant charge (2)	kg		15,1	
Gas circuits	n.		2	
Power supply (**)			400/3/50+N	
Max operating current (FLA) (*)	A		99,29	
Unit starting current (LRA)	A		164,29	
Energy efficiency indexes (1)				
EER (*)	kW/kW	3,69	2,67	2,47
Sound pressure level - ISO 3744 (3)				
On air delivery Over	dB(A)	63,1	70,9	70,9
On air delivery Under	dB(A)	63,1	71,0	71,0
On air intake Over	dB(A)	52,9	58,2	58,2
Irradiated Over	dB(A)	45,1	52,8	52,8
On air intake Under	dB(A)	55,1	62,4	62,4
On front side Under	dB(A)	45,7	53,0	53,0
Net weight Over	kg		910	
Net weight Under	kg		985	
Remote condenser (4)				
TEAM MATE	n. x Mod.		2 x M 50	
Refrigerant connections				
Gas delivery	ODS Ø		22	
Liquid return	ODS Ø		18	

THE COOLING CAPACITY DOES NOT CONSIDER THE SUPPLY FAN MOTOR THERMAL LOAD

1. Characteristics referred to entering air at 24°C-50%RH; 35°C ambient temperature.
2. Unit refrigerant charge. Remote condenser, connections pipes and optional are excluded.
3. Noise level at 1 meter in free field (external static pressure at nominal conditions)
4. For matching to other remote air cooled condensers please refer to RC WORLD selection program

(*) The value includes the remote condenser shown in the table.

(**) The remote condenser has separated power supply

TECHNICAL DATA - OPTIONAL ACCESSORIES

NEXT EVO INV		007	010	016	020	028	034	040	053	057	040	065	080	100
SIZE		S M1	S M1	S M1	S M1	S M1	S M2	S M2	S M3	S M3	D M11	D M11	D M22	D M22
		E0	E1	E2	E3	E4	E4	E5	E5	E6	E5	E7	E8	E9
Electric heater														
Capacity	kW	2,5	5,1	5,1	6,0	9,0	9,0	13,5	13,5	13,5	13,5	13,5	18,0	18,0
Capacity steps	n.	1	1	1	2	3	3	3	3	3	3	3	3	3
Humidifier														
Steam capacity	kg/h	2	3	3	3	8	8	8	8	8	8	15	15	15
Power input	kW	1,4	2,3	2,3	2,3	6,0	6,0	6,0	6,0	6,0	6,0	11,3	11,3	11,3
Extra circuit coil (1)														
Total cooling capacity	kW	-	11,0	18,1	24,7	39,0	43,3	55,4	64,2	69,5	63,3	94,2	117,0	135,0
Sensible cooling capacity	kW	-	10,0	16,5	22,4	35,4	39,4	49,7	59,0	63,3	52,5	80,0	98,3	115,0
Heating coil (2)														
Heating capacity	kW	12,6	24,1	36,2	50,5	81,4	89,8	109,0	126,0	148,0	109,0	160,0	193,0	232,0

THE COOLING/HEATING CAPACITY DOES NOT CONSIDER THE SUPPLY FAN MOTOR THERMAL LOAD
Accessories technical data are referred to nominal conditions.

1. Characteristics referred to entering air at 24°C 50%RH with chiller water at 7/12,5 °C and 0% glycol
2. Characteristics referred to entering air at 20°C with hot water at 75/60°C

DIMENSIONS (mm)

SIZE	a	b	c
E0	655	445	1680
E1	650	675	1925
E2	785	675	1925
E3	1085	775	1925
E4	1305	930	1980
E5	1630	930	1980
E6	1875	930	1980
E7	2175	930	1980
E8	2499	930	1980
E9	2899	930	1980

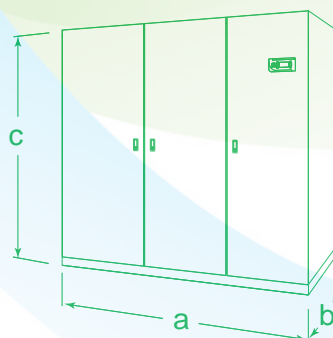

WAP
COOLING