

# RESIDENTIAL PRODUCT SELECTOR

PRODUCT SELECTOR

RESIDENTIAL

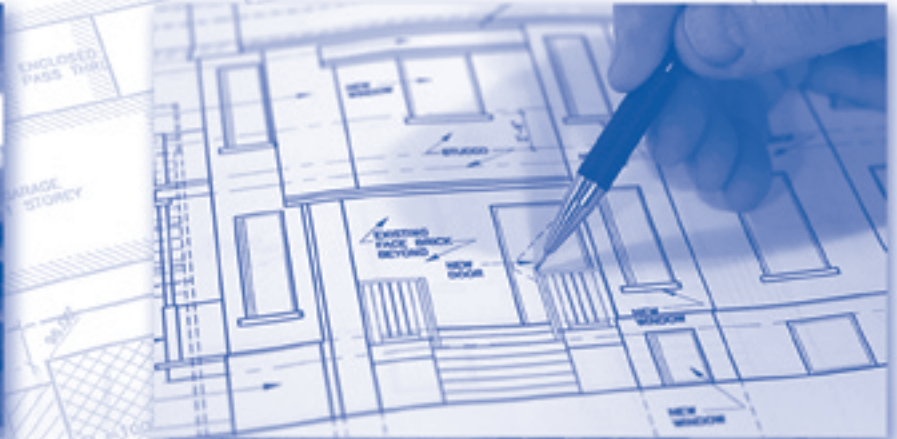

## QUEENSLAND

**Brisbane**, 30 French Street, Eagle Farm  
Phone: 3877 2844 Fax: 3877 2891  
hilite@gjames.com.au

**Logan City**, 23 Kingston Road, Woodridge  
Phone: 3827 6333 Fax: 3827 6349  
woodridge@gjames.com.au

**Capalaba**, 176 Redland Bay Road  
Phone: 3823 9090 Fax: 3823 9099  
woodridge@gjames.com.au

**Caboolture**, 40 Sodium Street, Narangba  
Phone: 3897 0811 Fax: 3897 0844  
narangba@gjames.com.au

**Ipswich**, 15 Verrall Street, Riverview  
Phone: 3810 5355 Fax: 3810 5399  
riverview@gjames.com.au

**Gold Coast**, 636 Nerang Road, Ashmore  
Phone: 5588 5755 Fax: 5588 5799  
goldcoast@gjames.com.au

**Toowoomba**, 319 Taylor Street  
Phone: 4690 2111 Fax: 4690 2149  
toowoomba@gjames.com.au

**Sunshine Coast**, Maroochydore Road,  
Kunda Park  
Phone: 5430 4544 Fax: 5430 4549  
maroochydore@gjames.com.au

**Gympie**, 6 Bonnick Road  
Phone: 5480 6666 Fax: 5480 6699  
gympie@gjames.com.au

**Hervey Bay**, Booral Road, Urangan  
Phone: 4128 5733 Fax: 4128 5749  
hervey\_bay@gjames.com.au

**Bundaberg**, 49-51 Enterprise Street  
Phone: 4155 4888 Fax: 4155 4899  
bundaberg@gjames.com.au

**Gladstone**, 32 Benaraby Road  
Phone: 4970 0500 Fax: 4970 0549  
gladstone@gjames.com.au

**Rockhampton**, Featherstone Street  
Phone: 4931 3977 Fax: 4931 3999  
rockhampton@gjames.com.au

**Mackay**, 9 David Muir Street, Slade Point  
Phone: 4955 4860 Fax: 4955 4868  
mackay@gjames.com.au

**Townsville**, 599 Ingham Road, Garbutt  
Phone: 4753 4600 Fax: 4753 4699  
townsville@gjames.com.au

**Cairns**, 28 Redden Street, Portsmith  
Phone: 4042 9388 Fax: 4042 9389  
cairns@gjames.com.au

## NEW SOUTH WALES

**Sydney**, 26 Long Street, Smithfield  
Phone: 9732 2477 Fax: 9732 2432  
sydney\_contracting@gjames.com.au

**Newcastle**, 65 Pendlebury Road, Cardiff  
Phone: 4940 3444 Fax: 4940 3449  
newcastle@gjames.com.au

**Taree**, 10 Grey Gum Road  
Phone: 6539 3811 Fax: 6539 3819  
taree@gjames.com.au

**Port Macquarie**, 6 Uralla Road  
Phone: 6580 7488 Fax: 6580 7499  
port\_macquarie@gjames.com.au

**Lismore**, 25 Habib Drive, South Lismore  
Phone: 6627 4000 Fax: 6627 4049  
lismore@gjames.com.au

## NORTHERN TERRITORY

**Darwin**, 97 Winnellie Road, Winnellie  
Phone: 8944 3111 Fax: 8944 3119  
darwin@gjames.com.au

## SOUTH AUSTRALIA

**Adelaide**, 263 Edinburgh Rd, Edinburgh  
Phone: 8182 7888 Fax: 8182 7899  
adelaide@gjames.com.au

**WEBSITE:** [www.gjames.com.au](http://www.gjames.com.au)

Front photo of residence courtesy of Craig Cleary Constructions (Maroochydore, Qld).

### Disclaimer

This booklet is the property of G.James Australia Pty Ltd and shall not be reproduced, copied, imitated or extracted from in any way whatsoever without the written permission of G.James Australia Pty Ltd. All rights reserved. ©2011.

G.James has been careful and diligent to ensure the accuracy of all the information contained in this booklet but to the extent limited by law, G.James accepts no responsibility for any inaccuracies of any kind.

Due to continual product development, changes within the window industry and amendments to relevant standards, G.James reserves the right to add, alter or delete any information or offers contained in this booklet without notice.

**Authorised Distributor**

	Page
<b>Introduction</b>	<b>(ii)</b>
<b>Selection Criteria</b>	<b>(iii)</b>
<b>Window Energy Rating Scheme (WERS)</b>	<b>(iv)</b>
<b>AFRC / WERS Certified Products (Extract)</b>	<b>(v)</b>
<b>048 Series Awning and Casement Windows</b>	
Size Range / Available Configurations	1 - 3
Possible Configurations	4
<b>050 Series Louvre Window</b>	
Standard Heights	5
Possible Configurations	6
<b>131 Series Sliding and Fixed Windows</b>	
Standard Size Range	7 - 8
Possible Configurations	9 - 10
<b>136 Series Double Hung Window</b>	
Standard Size Range	11 - 12
Possible Configurations	13
<b>140 Series Fly, Security and Crimsafe Screens</b>	
Product Range	14
<b>245 Series Sliding Door</b>	
Standard Size Range	15
Standard Size Range – Corner Door Configurations	16
Possible Configurations	17
Possible Configurations – Five (5) Track System	18
<b>470/474 Series Hinged Doors</b>	
Standard Size Range / Possible Configurations	19
<b>472 Series Hinged Door</b>	
Possible Configurations / Construction Details	20
<b>477 Series Bi-Fold Door</b>	
Possible Configurations	21
<b>801 Series Wardrobe Door</b>	
Size Range / Possible Configurations	22
<b>826/830 Series Showerscreen</b>	
Possible Configurations	23 - 24
<b>Window Speak</b>	25 – 26
<b>Maintenance Instructions</b>	27
<b>Guarantee</b>	28

Established in 1917, G.James is today Australia's leading integrated glass & aluminium manufacturer and contractor.

For the home builder this means your dealing with a company that has over 90 years experience in the building industry, such a record doesn't come about without the products and service to back it up. Significant levels of integration ensures G.James has complete control of your order – from extruding the aluminium profiles through to delivery of your order on-site.

We also take pride in our extensive network of branches and total commitment to product development and customer service. To allow the home builder and renovator to consider all their options before finalising plans and nominating the window supplier, G.James is pleased to offer this booklet to assist you in this process. Our comprehensive range of products, finishes and glass types will help to enhance every room in your new home, and we're confident that choosing G.James windows and doors will be one of the easiest decisions of your building experience.

During the building process a considerable amount of thought is given to selecting the type of brick, style of kitchen and colour of the bathrooms, however in many instances little consideration is given to the windows and doors.

These elements are responsible for allowing natural light and ventilation into the home, maximising our views and providing degrees of security and privacy. It should also be remembered that windows and doors comprise around 25% of the average homes external appearance. With all this in mind you can appreciate why the selection of **your** windows and doors deserves some attention.

G. James Glass & Aluminium is passionate about educating the home owner in what we believe to be important criteria to consider when selecting windows and doors.

## Colour Selection

Choosing the right colour for your window and door framing is crucial for enhancing your internal and external colour schemes, and ultimately for re-sale purposes. G. James is well aware of this aspect and annually reviews their standard powder coat colour range to keep up with market trends. In addition, we offer an extensive range of anodised finishes including new multi-colour anodising. Refer to the G. James Residential Colour Selector for further details.

## Glass Selection

Reducing external noise, saving on heating and / or cooling costs, extending the life of soft furnishings, reduced glare and extra security are some of the benefits achievable through correct glass selection. G. James has a comprehensive range of tinted, laminated and high performance glass products on offer to satisfy your glazing requirements.

## Certification

Are the windows you're purchasing tested, certified, inspected and guaranteed? The Australian Window Association (AWA) Product Accreditation Program ensures that accredited members manufacture their windows and doors to exacting performance criteria. As an accredited member, every aspect of G. James' method of window construction is subject to

3rd party annual audits to ensure continuing compliance.

This is in addition to the fact that AWA members are required to produce windows and doors which meet the requirements of all relevant Australian Standards. G. James is a strong advocate of marketing products that provide genuine performance and guaranteed reliability.

## Features and Benefits

Consumer research has consistently revealed that between 70 – 80% of people buy on 'quality / perceived value' of a product or service rather than 'price'.

In the case of windows and doors, quality / value can be assessed in terms of the **extra** features and **long term** benefits offered by the product. So before deciding on which company will supply your windows, or offered a particular window as standard, ask the following questions:

- Does the window have a sill inlay and the sliding door a threshold for easy access to, and cleaning of the sill?
- Are the flyscreens easily removed both internally and externally (an important feature particularly for two storey homes)?
- Are the window handles located at the mullion (not at the jambs behind curtains making access difficult)?
- Do the window rollers contain stainless steel bearings (important for long term performance)?
- Do the window rollers have a 16mm dia. tyre (smaller tyres can develop flat spots which causes the roller to skid along the track rather than roll)?
- Are the rollers height adjustable?

Finally, G. James residential extrusions are manufactured in Australia from billet produced using recycled aluminium. This billet requires approx. 90% less power than original billet.

We encourage you to contact our sales team so we can further explain the advantages in selecting G. James Glass & Aluminium as the supplier of windows and doors for your new home.

Surprisingly windows are one of the most complex and important (comfort) elements in today's home. Whilst providing light, fresh air and views, windows represent a major source of unwanted heat loss in winter & heat gain in summer.

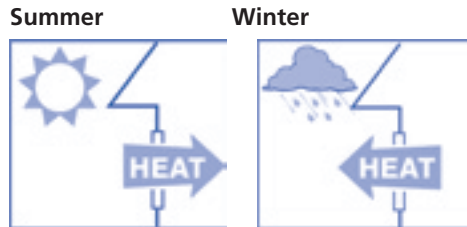

Recent advances in glazing materials have improved the performance of windows to the extent where energy efficient windows make your home more comfortable and significantly reduces your energy costs.

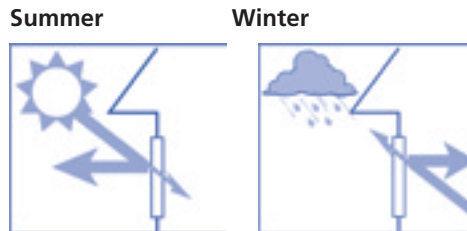

WERS (Window Energy Rating Scheme) rates the energy impact of residential windows in Australia. With up to 40% of a home's energy for cooling and heating being lost or gained through the windows, improving their thermal performance reduces energy costs and greenhouse gas emissions.

The aim of WERS is to help home builders and home owners evaluate the relative energy (heating and cooling) performance of different types of windows by rating that performance in terms of stars. 'No star' indicates a very poor performing window whilst '10 stars' signifies superior performance.

**G. James Whole of Window (WOW) Performance**  
WOW performance figures are provided by WERS and have been determined using NFRC / AFRC<sup>1</sup> protocols & procedures. They are appropriate for use in the Building Code of Australia (BCA) Glazing Calculator which assesses glazing compliance to the Energy Efficiency section of the BCA. The results contained within the WERS Certified Product Directory can also be used for matching NFRC performance figures from BASIX<sup>2</sup> and for second generation 'whole of house' software tools such as AccuRate, BERSPro and FirstRate5.

For further information visit [www.wers.net](http://www.wers.net)

<sup>1</sup> NFRC is the National Fenestration Rating Council. AFRC is the Australian Fenestration Rating Council.

<sup>2</sup> BASIX is the Building Sustainability Index.

## Different Windows for Different Climates

Not all windows perform the same in different climates. Orientation and shading can also influence the performance of a window within a home.

### Cooling Climate

*This is where cooling your home and preventing heat gain is the priority.*

Select window types with a lower Solar Heat Gain Coefficient (SHGC<sub>w</sub>) and those that provide good ventilation such as G. James 050 Series louvres. A lower U-value (U<sub>w</sub>) also improves the overall thermal performance. Choose products glazed with a tinted glass or one of the high performance products from the G. James SOLECT® range.

### Heating Climate

*This is where heating your home and preventing heat loss is the priority.*

This can be achieved by installing window types with a lower U-value as they reduce heat loss to the outside during the cooler, winter months. Choose products that are double glazed (IGU) or one of the high performance products from the G. James SOLECT® range.

### Mixed Climate

*This is where both heating and cooling your home is a concern.*

In a mixed climate, consider whether heating or cooling is the primary motivation. Whichever is the case, refer to the relevant 'Cooling' or 'Heating' recommendations above. If neither heating nor cooling prevails, a lower U-value product provides better thermal performance. Whilst a lower SHGC product can reduce the solar heat gain from the window.

## Definition and Terms – refer Table Page (v)

### Glazing Type

Glass Type used in the window

### Cooling Stars - ★

Window performance rating in a cooling dominated environment.

### Heating Stars - ★

Window performance rating in a heating dominated environment.

### U<sub>w</sub> - Window U-value (Insulating Ability)

The measure of the air-to-air heat transfer (either loss or gain) due to thermal (heat) conductance due to the difference between indoor and outdoor temperatures. The lower the U-value, the lower the heat transferred and the better the performance.

### SHGC<sub>w</sub> - Window Solar Heat Gain Coefficient

The ratio of solar radiation (light and heat) from the sun that is initially transmitted through the window plus a proportion of absorbed energy which is re-radiated back inside. A rating of "1" represents an open hole in the wall whilst a "0" represents a solid wall. The lower this figure, the better the window is at excluding and eliminating solar radiation.

### T<sub>vw</sub> - Visible Light Transmission

Visible Light Transmittance is the percentage of light transmitted through the glass where 100% represents an open hole in the wall.



Below is a sample of G.James products and their respective Whole of Window (WOW) performance which are provided by WERS and been determined using NFRC/AFRC protocols and procedures. For a complete list of G.James WERS Certified Products go to: [www.gjames.com.au](http://www.gjames.com.au)

Product: 048 Series Awning Window	WERS		AFRC		
Glazing Type	Cooling Stars	Heating Stars	Uw	SHGCw	Tvw
3mm Clear	★	★★★★☆	6.4	0.62	62%
5mm Grey	★★	★★★	6.3	0.45	35%
5mm Evergreen	★★☆	★★★	6.3	0.43	50%
6.38mm Solect Clear Low E Laminate	★★☆	★★★★☆	4.9	0.50	56%
6.38mm Solect Green Low E Laminate	★★★	★★★★	4.9	0.37	49%
6.38mm Solect Grey Low E Laminate	★★★★☆	★★★★	4.9	0.33	33%
4mm Clear/12mm Air/4mm Clear IGU	★★☆	★★★★★☆	4.0	0.56	58%
Product: 131 Series Sliding Window	WERS		AFRC		
Glazing Type	Cooling Stars	Heating Stars	Uw	SHGCw	Tvw
3mm Clear	☆	★★	6.5	0.77	79%
5mm Grey	★☆	★☆	6.4	0.55	44%
5mm Evergreen	★★	★☆	6.4	0.51	64%
6.38mm Solect Clear Low E Laminate	★★	★★★★☆	4.5	0.60	71%
6.38mm Solect Green Low E Laminate	★★★	★★★	4.5	0.44	62%
6.38mm Solect Grey Low E Laminate	★★★	★★★	4.5	0.39	42%
4mm Clear/12mm Air/4mm Clear IGU (075 Series)	★★	★★★★☆	4.0	0.63	67%
Product: 136 Series Double Hung Window	WERS		AFRC		
Glazing Type	Cooling Stars	Heating Stars	Uw	SHGCw	Tvw
3mm Clear	☆	★★	6.5	0.73	75%
5mm Grey	★☆	★☆	6.4	0.53	42%
5mm Evergreen	★★	★☆	6.4	0.49	61%
6.38mm Solect Clear Low E Laminate	★★	★★★★☆	4.6	0.58	68%
6.38mm Solect Green Low E Laminate	★★★	★★★	4.6	0.43	59%
6.38mm Solect Grey Low E Laminate	★★★★☆	★★★	4.6	0.37	40%
4mm Clear/12mm Air/4mm Clear IGU (138 Series)	★★	★★★★	4.0	0.59	62%
Product: 245 Series Sliding Door	WERS		AFRC		
Glazing Type	Cooling Stars	Heating Stars	Uw	SHGCw	Tvw
4mm Clear	☆	★★☆	6.3	0.72	76%
5mm Grey	★★	★★	6.3	0.52	43%
5mm Evergreen	★★	★★	6.3	0.49	62%
6.38mm Solect Clear Low E Laminate	★★	★★★★	4.4	0.58	69%
6.38mm Solect Green Low E Laminate	★★★	★★★★☆	4.3	0.42	60%
6.38mm Solect Grey Low E Laminate	★★★★☆	★★★	4.4	0.37	40%
4mm Clear/10mm Air/4mm Clear IGU	★★	★★★★☆	4.0	0.63	67%
Product: 472 Series Hinged Door	WERS		AFRC		
Glazing Type	Cooling Stars	Heating Stars	Uw	SHGCw	Tvw
4mm Clear	★	★★	6.2	0.63	64%
5mm Grey	★★	★☆	6.2	0.47	36%
5mm Evergreen	★★☆	★☆	6.2	0.44	52%
6.38mm Solect Clear Low E Laminate	★★☆	★★★★☆	4.4	0.51	58%
6.38mm Solect Green Low E Laminate	★★★★☆	★★★	4.4	0.38	50%
6.38mm Solect Grey Low E Laminate	★★★★☆	★★☆	4.4	0.34	34%
4mm Clear/12mm Air/4mm Clear IGU	★★☆	★★★★	4.1	0.56	58%

NOTES:

- For the full definition of the terms detailed in the above table, refer to Page (iv) (opposite).
- Uw is the whole window U-value.
- SHGCw is the whole window solar heat gain coefficient.
- Tvw is the whole window visible (light) transmittance.
- Static performance (Uw SHGCw, Tvw) calculated using Window 5.2 and Therm 5.2 software (LBNL), 2000-2003.
- Annual energy performance stars calculated using Nationwide House Energy Rating Software (AccuRate) according to procedures of WERS 2008.
- Results disclosed at National Fenestration Rating Council (NFRC) regulations.
- These results are consistent with Australian Fenestration Rating Council (AFRC) protocols and procedures.

# 048 Series Awning Window

## STANDARD SIZE RANGE

Stud Opening with Reveal (Includes 10mm Clearance)		Aluminium Frame Size							
		WIDTH							
		500	660	960	1260	1560	1860	2160	2460
		450	610	910	1210	1510	1810	2110	2410
HEIGHT	500								
	650								
	950								
	1250								
	1550								
	1850								

### Note:

- All dimensions stated are in millimetres.
- When ordering, always state the height dimension first.
- All aluminium frame sizes detailed above refer to the outer frame dimensions exclusive of the fixing fin.
- All configurations are viewed from the outside looking inside.
- Multiple bay configurations will be supplied in equal splits unless requested otherwise.
- Black chainwinder and hardware are supplied as standard.
- Minimum window width for a 'centre drive' chainwinder is 540mm. Minimum window width for 'off-centre drive' winder is 450mm.
- Drawings may not be to scale.
- The above size parameters are based on an 'N3 Housing' design wind load category. The availability of certain sizes (larger and smaller) and configurations will vary depending on the design wind load requirement for the site. Check with your G.James Representative to confirm availability.
- Available on request (additional charges apply):
  - Timber reveals: finger joint pine (FJP), primed FJP, clear pine, meranti and LOSP treated types are available. When ordering nominate reveal type and width required.
  - Security, acoustic and energy efficient upgrades; non-standard sizes; and colonial, french or federation style glazing bars.



# 048 Series Awning Window

## STANDARD SIZE RANGE

		STUD OPENING WITH REVEAL (INCLUDES 10MM CLEARANCE)						
		ALUMINIUM FRAME SIZE						
		WIDTH						
		660	960	1260	1560	1860	2160	2460
		610	910	1210	1510	1810	2110	2410
HEIGHT	950							
	900							
	1250							
	1200							
1850								
1800								
2450								
2400								

**Note:**

- All dimensions stated are in millimetres.
- When ordering, always state the height dimension first.
- All aluminium frame sizes detailed above refer to the outer frame dimensions exclusive of the fixing fin.
- All configurations are viewed from the outside looking inside.
- Multiple bay configurations will be supplied in equal splits unless requested otherwise.
- Black chainwinder and hardware are supplied as standard.
- Minimum window width for a 'centre drive' chainwinder is 540mm. Minimum window width for 'off-centre drive' winder is 450mm.
- Drawings may not be to scale.
- The above size parameters are based on an 'N3 Housing' design wind load category. The availability of certain sizes (larger and smaller) and configurations will vary depending on the design wind load requirement for the site. Check with your G.James Representative to confirm availability.
- Available on request (additional charges apply):
  - Timber reveals: finger joint pine (FJP), primed FJP, clear pine, meranti and LOSP treated types are available. When ordering nominate reveal type and width required.
  - Security, acoustic and energy efficient upgrades; non-standard sizes; and colonial, french or federation style glazing bars.

# 048 Series Casement Window

## STANDARD SIZE RANGE

		STUD OPENING WITH REVEAL (INCLUDES 10MM CLEARANCE)							
		ALUMINIUM FRAME SIZE							
		WIDTH							
		510	660	960	1260	1560	1860	2160	2460
		460	610	910	1210	1510	1810	2110	2410
HEIGHT	950								
	900								
	1250								
1200									
1550									
1500									

### Handing Options

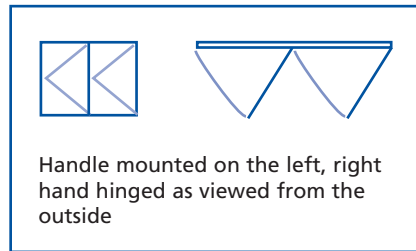
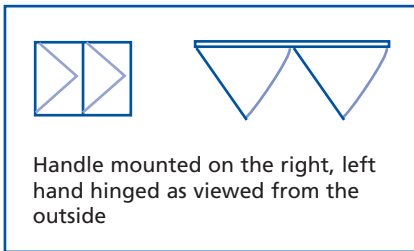

### Note:

- All dimensions stated are in millimetres.
- When ordering, always state the height dimension first.
- When ordering, nominate the handing of the window, ie. the position, either left or right, of the handle as viewed from the outside.
- All aluminium frame sizes detailed above refer to the outer frame dimensions exclusive of the fixing fin.
- All configurations are viewed from the outside looking inside.
- Multiple bay configurations will be supplied in equal splits unless requested otherwise.
- Black hardware is supplied as standard (excluding stays).
- Drawings may not be to scale.
- The availability of certain sizes and configurations is dependent on the design wind load requirement of the site. Check with your G.James Representative to confirm availability.
- Available on request (additional charges apply):
  - Timber reveals: finger joint pine (FJP), primed FJP, clear pine, meranti and LOSP treated types are available. When ordering nominate reveal type and width required.
  - Security, acoustic and energy efficient upgrades; non-standard sizes; and colonial, french or federation style glazing bars.

# 048 Series Awning Window

## POSSIBLE CONFIGURATIONS

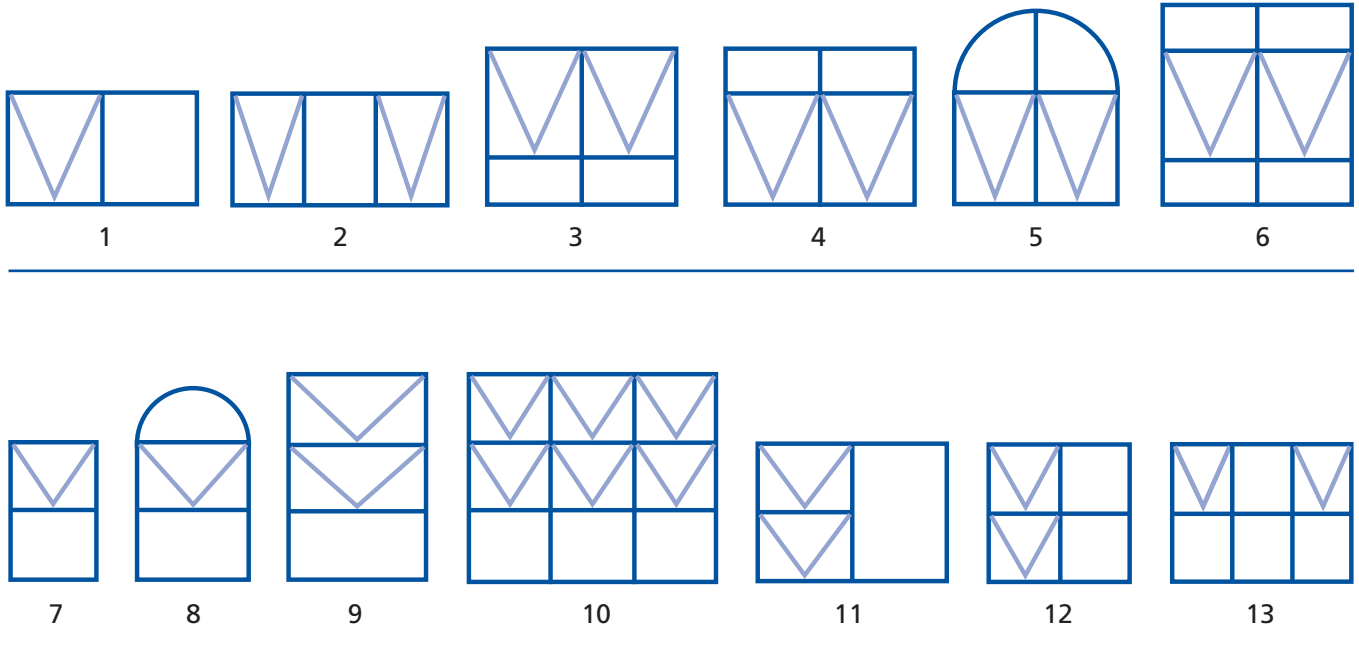

# 048 Series Casement Window

## POSSIBLE CONFIGURATIONS

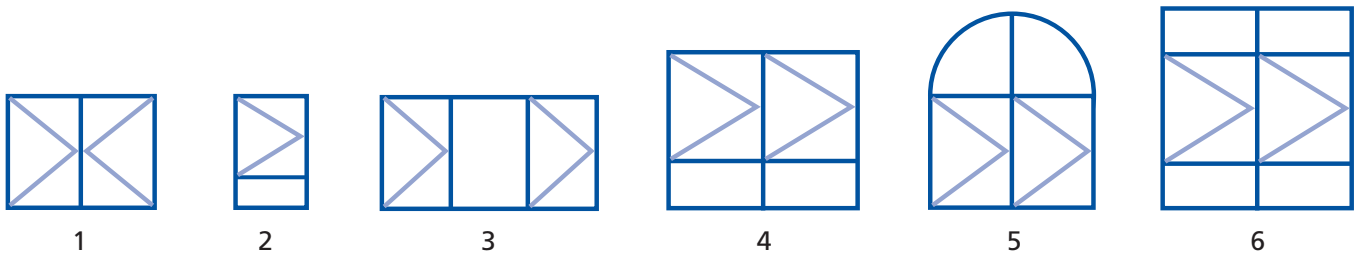

## DECORATIVE FEATURES

### Colonial Bars

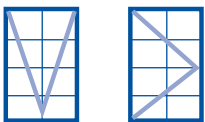

### Federation Bars

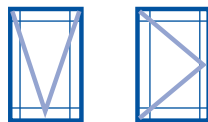

### 474 Series French Style Glazing Bar

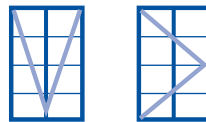

### Note:

- All dimensions are stated in millimetres.
- When ordering, always state the height dimension first.
- When ordering, state the outer frame dimensions exclusive of the fixing fin.
- All configurations are viewed from the outside looking inside
- Multiple bay configurations will be supplied in equal vertical splits unless requested otherwise. Customer is to nominate the height of all horizontal splits.
- Multiple bay configurations will be supplied with transom(s) and / or mullion(s) as required.
- Black hardware is supplied as standard (excluding stays).
- Other configurations may be available upon request. The availability of certain sizes and configurations is dependent on the design wind load requirement of the site. Check with your G. James Representative to confirm availability.
- Drawings may not be to scale.
- Available upon request (additional charges apply):
  - Timber reveals: finger joint pine (FJP), primed FJP, clear pine, meranti and LOSP treated types are available. When ordering nominate reveal type and width required.
  - Security, acoustic and energy efficient upgrades.

## STANDARD HEIGHTS

102mm ALTAIR™ LOUVRE				130mm LOUVRE				152mm ALTAIR™ LOUVRE					
GALLERIES ONLY		48mm FRAME	101mm FRAME	GALLERIES ONLY		48mm FRAME	101mm FRAME	GALLERIES ONLY		48mm FRAME	101mm FRAME		
Blades	mm	mm	mm	Blades	mm	mm	mm	Blades	mm	mm	mm		
3	310	336	361	2	261	287	312	2	320	346	371		
4	400	426	451	3	378	404	429	3	460	486	511		
5	490	516	541	4	496	522	547	4	600	626	651		
6	580	606	631	5	613	639	664	5	740	766	791		
7	670	696	721	6	731	757	782	6	880	906	931		
8	760	786	811	7	848	874	899	7	1020	1046	1071		
9	850	876	901	8	966	992	1017	8	1160	1186	1211		
10	940	966	991	9	1083	1109	1134	9	1300	1326	1351		
11	1030	1056	1081	10	1201	1227	1252	10	1440	1466	1491		
12	1120	1146	1171	11	1318	1344	1369	11	1580	1606	1631		
13	1210	1236	1261	12	1435	1461	1486	12	1720	1746	1771		
14	1300	1326	1351	13	1553	1579	1604	13	1860	1886	1911		
15	1390	1416	1441	14	1671	1697	1722	14	2000	2026	2051		
16	1480	1506	1531	15	1788	1814	1839	15	2140	2166	2191		
17	1570	1596	1621	16	1905	1931	1956	16	2280	2306	2331		
18	1660	1686	1711	17	2023	2049	2074	17	2420	2446	2471		
19	1750	1776	1801	18	2141	2167	2192	18	2560	2586	2611		
20	1840	1866	1891	19	2258	2284	2309	19	2700	2726	2751		
21	1930	1956	1981	20	2375	2401	2426	20	2840	2866	2891		
22	2020	2046	2071	21	2493	2519	2544	21	2980	3006	3031		
23	2110	2136	2161	22	2611	2637	2662	22	3120	3146	3171		
24	2200	2226	2251	23	2728	2754	2779	MINIMUM 152mm BLADE EXTENSION IS 70mm					
25	2290	2316	2341	24	2845	2871	2896						
26	2380	2406	2431	25	2963	2989	3014						
27	2470	2496	2521	26	3081	3107	3132						
28	2560	2586	2611	MAXIMUM BLADE WIDTHS (mm)				MAXIMUM BLADE WIDTHS (mm)					
29	2650	2676	2701	WIND LOAD	GLASS		TIMBER	ALUM	WIND LOAD	GLASS		TIMBER	ALUM
30	2740	2766	2791		FLOAT	TOUGH				FLOAT	TOUGH		
31	2830	2856	2881	1000 Pa	865	900	840	1230	1000 Pa	865	900	900	1000
32	2920	2946	2971	1500 Pa	750	900	840	1153	1500 Pa	750	900	900	875
33	3010	3036	3061	2200 Pa	600	870	810	1010	2200 Pa	600	870	867	750

MINIMUM 102mm BLADE EXTENSION IS 46mm

### MAXIMUM BLADE WIDTHS (mm)

WIND LOAD	GLASS		TIMBER	ALUM
	FLOAT	TOUGH		
1000 Pa	865	900	750	900
1500 Pa	750	900	750	850
2200 Pa	600	870	722	750

### Note:

- All dimensions are stated in millimetres and refer to single bay units.
- When ordering, always state the height dimension first and the outer frame dimensions (excluding the fixing fin).
- When ordering, nominate width of clip (either 102, 130 or 152mm) and frame width (either 48 or 101mm).
- Wind loads stated above are Serviceable pressures.
- Black hardware and clips are supplied as standard unless requested otherwise.
- The maximum blade widths may vary depending on the water penetration requirements. Check with your G.James representative to confirm.
- Available upon request (additional charges apply):
  - Timber reveals: finger joint pine (FJP), primed FJP, clear pine, meranti and LOSP treated types are available. When ordering nominate reveal type and width required.
  - Tinted glass blades.
- Altair is a trademark of Breezway Australia.

# 050 Series Louvre Window

## POSSIBLE CONFIGURATIONS

All Glass, Aluminium  
or Timber Blade



Any combination of Glass,  
Aluminium and Timber Blades  
within the single frame

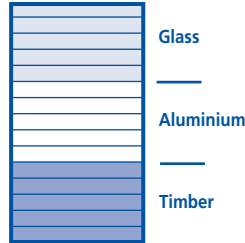

Multiple Bays  
(No limit to number  
of continuous bays)

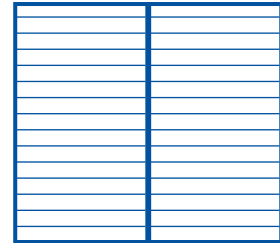

Coupled to  
Sliding Window

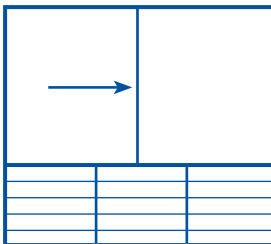

Coupled to Fixed  
Light Unit

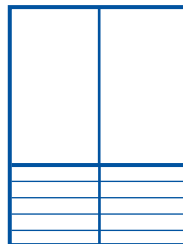

Coupled to  
Window Wall

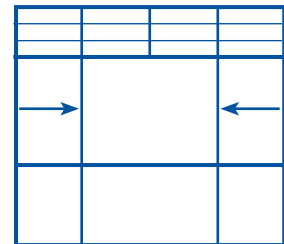

Coupled to Sliding  
Door as a High Light

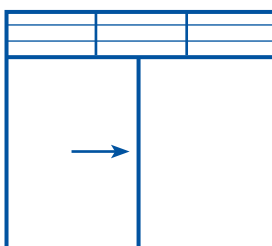

Coupled to Sliding Door  
as a Side Light

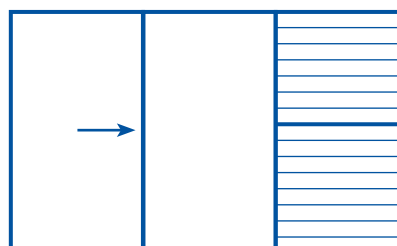

Side light can be coupled to fixed  
panel side only

### Note:

- All dimensions are stated in millimetres.
- When ordering, always state the height dimension first.
- When ordering, state the outer frame dimensions exclusive of the fixing fin.
- All configurations are viewed from the outside looking inside.
- Multiple bay configurations will be supplied in equal splits unless requested otherwise. When ordering, nominate height / width of any splits.
- Multiple bay configurations will be supplied with transom(s) and / or mullion(s) as required.
- Black hardware and clips are supplied as standard unless requested otherwise.
- Other configurations may be available upon request. The availability of certain sizes and configurations is dependent on the design wind load requirement of the site. Check with your G.James Representative to confirm availability.
- Drawings may not be to scale.
  - Timber reveals: finger joint pine (FJP), primed FJP, clear pine, meranti and LOSP treated types are available. When ordering nominate reveal type and width required.
  - Tinted glass blades.

# 131 Series Sliding Window

## STANDARD SIZE RANGE

Stud Opening with Reveal (Includes 10mm Clearance)

Aluminium Frame Size

WIDTH

		660	960	1260	1560	1860	2160	2460	2760	3060
		610	910	1210	1510	1810	2110	2410	2710	3010
HEIGHT	650									
	950									
1050	1000									
1250	1200									
1550	1500									

### Legend

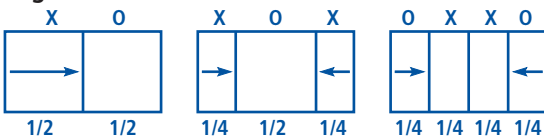

**Note: This size range also applies to the 075 Series double glazed sliding window (XO & XOX configurations only available).**

### Note:

- All dimensions stated are in millimetres.
- When ordering, always state the height dimension first.
- All aluminium frame sizes detailed above refer to the outer frame dimensions of the window exclusive of the fixing fin.
- All configurations are viewed from the outside looking inside.
- All two panel windows will be supplied as XO (slider / fixed) unless requested otherwise.
- Black hardware is supplied as standard.
- Drawings may not be to scale.
- The availability of certain sizes and configurations is dependent on the design wind load requirement of the site. Check with your G.James Representative to confirm availability.
- Available on request (additional charges apply):
  - Timber reveals: finger joint pine (FJP), primed FJP, clear pine, meranti and LOSP treated types are available. When ordering nominate reveal type and width required.
  - Security, acoustic and energy efficient upgrades.
  - Non-standard sizes.
  - Fixed vent fitted to window sashes.
  - Colonial or federation style bars.



# 131 Series Window Wall

## STANDARD SIZE RANGE

Stud Opening with Reveal (Includes 10mm Clearance)

Aluminium Frame Size

WIDTH

		960	1260	1560	1860	2160	2460	2760	3060
		910	1210	1510	1810	2110	2410	2710	3010
HEIGHT	1850							* Not available as a 1500/300mm split	
	1800								
	2150							* Not available as a 1500/600mm split	
	2100								

### 1800mm high

### Legend

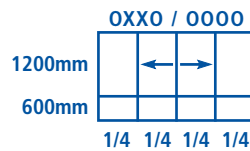
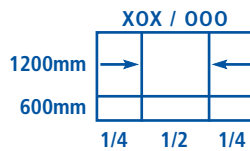
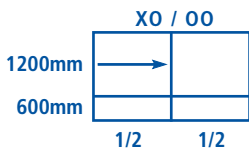

A 1200mm / 600mm height split will be supplied to all 1800mm window walls unless requested otherwise

### 2100mm high

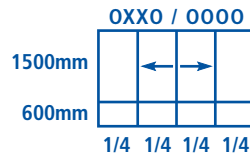
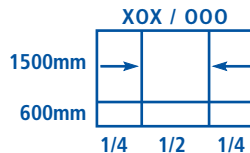
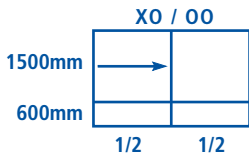
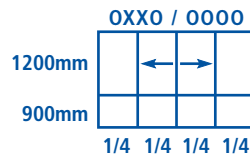
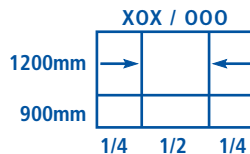
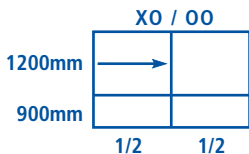

Customer is to nominate the height splits on all 2100mm high window walls

### Options

#### XO / XO Window Wall



#### XO with 2 Bay Louvre Low Light



#### Window Wall with Semi-Circle Head



#### Window Wall with Raked Head



### Note:

- All dimensions stated are in millimetres.
- When ordering, always state the height dimension first.
- All aluminium frame sizes detailed above refer to the outer frame dimensions of the window exclusive of the fixing fin.
- All configurations are viewed from the outside looking inside.
- All two panel windows to the upper portion of a window wall will be supplied as XO (slider / fixed) unless requested otherwise.
- Black hardware is supplied as standard.
- Height splits refer to the centre of the transom.
- Drawings may not be to scale.
- All panels to the lower portion of a window wall will be supplied as fixed panels unless requested otherwise.
- The availability of certain sizes and configurations is dependent on the design wind load requirement of the site. Check with your G.James Representative to confirm availability.
- Available on request (additional charges apply):
  - Timber reveals: finger joint pine (FJP), primed FJP, clear pine, meranti and LOSP treated types are available. When ordering nominate reveal type and width required.
  - Security, acoustic and energy efficient upgrades.
  - Non-standard sizes.
  - Colonial or federation style bars.

# 131 Series Sliding Window

## POSSIBLE CONFIGURATIONS

With Semi-Circle Head

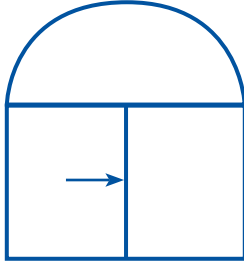

With Split Semi-Circle Head

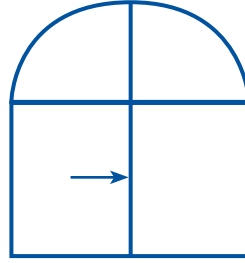

With Raked Head

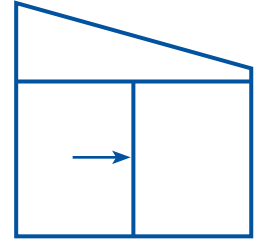

# 131 Series Bay Windows

## POSSIBLE CONFIGURATIONS

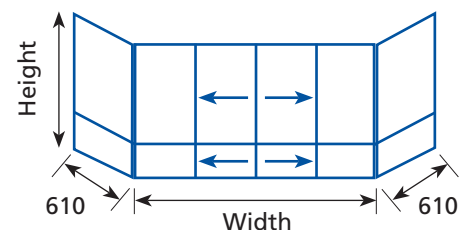
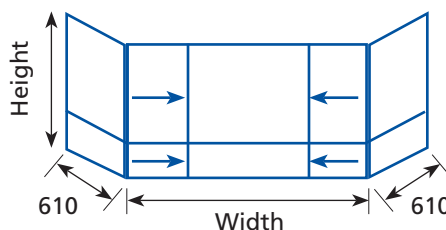
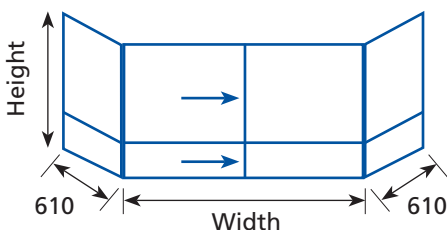
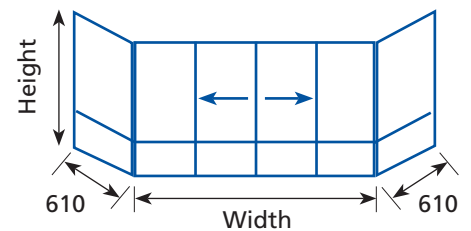
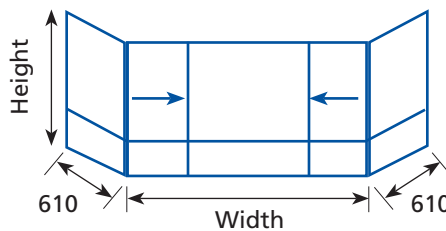
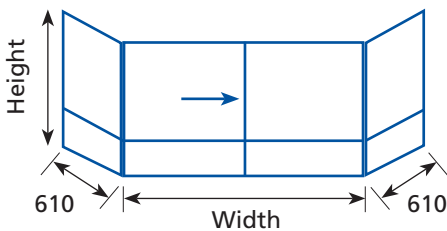
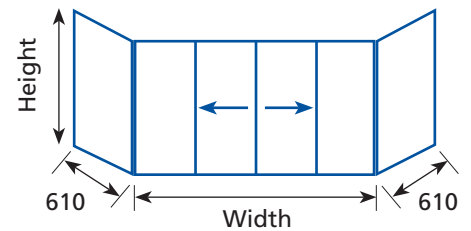
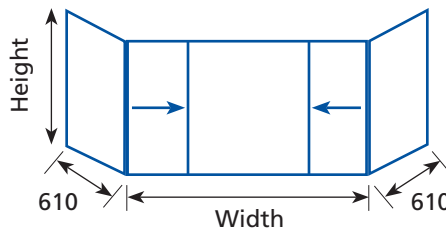
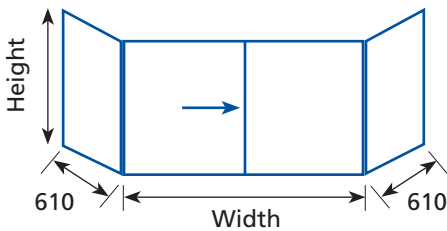

**Note:**

- All dimensions stated are in millimetres.
- When ordering, always state the height dimension first.
- All configurations are viewed from the outside looking inside.
- Standard height and width dimensions are as per the 131 Series sliding window and window wall size range.
- Bay window configurations illustrated above show a 135° angle, 90° available upon request.
- Drawings may not be to scale.
- The availability of certain sizes and configurations is dependent on the design wind load requirement of the site. Check with your G.James Representative to confirm availability.
- Available on request (additional charges apply):
  - Timber reveals: finger joint pine (FJP), primed FJP, clear pine, meranti and LOSP treated types are available. When ordering nominate reveal type and width required.
  - Security, acoustic and energy efficient upgrades.
  - Non-standard sizes.
  - Colonial or federation style bars.

## POSSIBLE CONFIGURATIONS

### Rectangle / Square

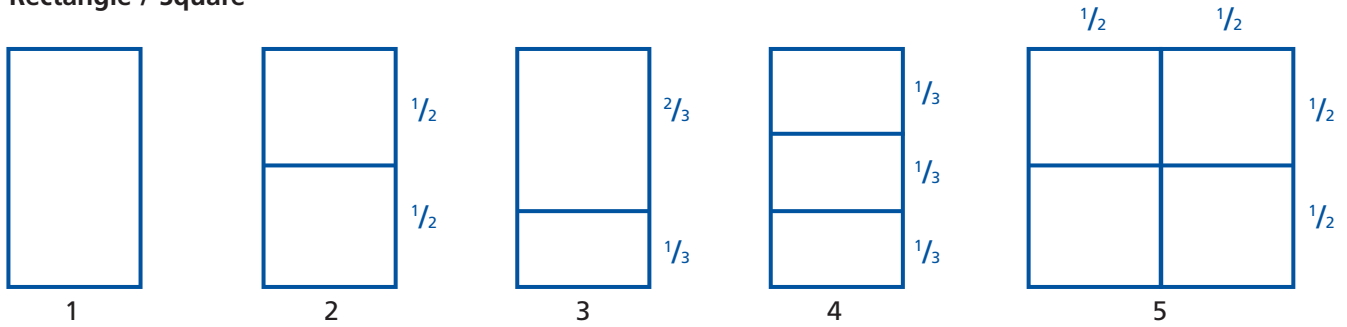

### Circle

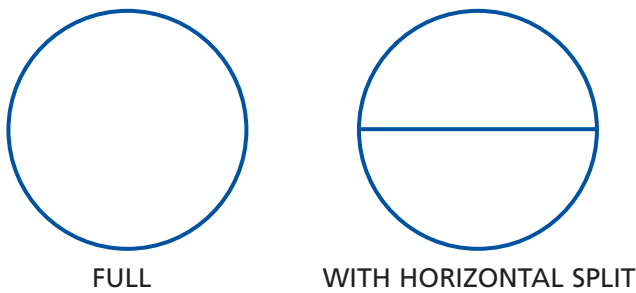

### Semi-Circle

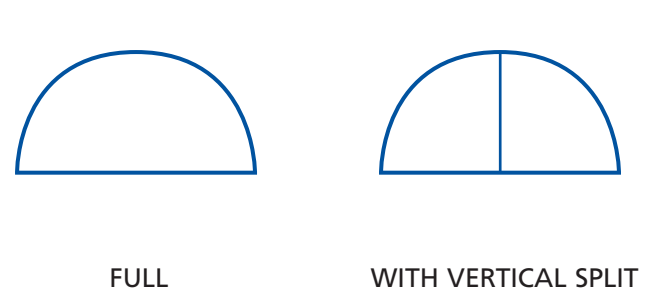

### Arch (to template only)

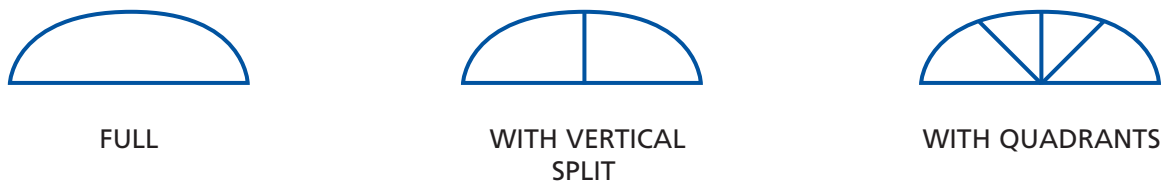

### Other

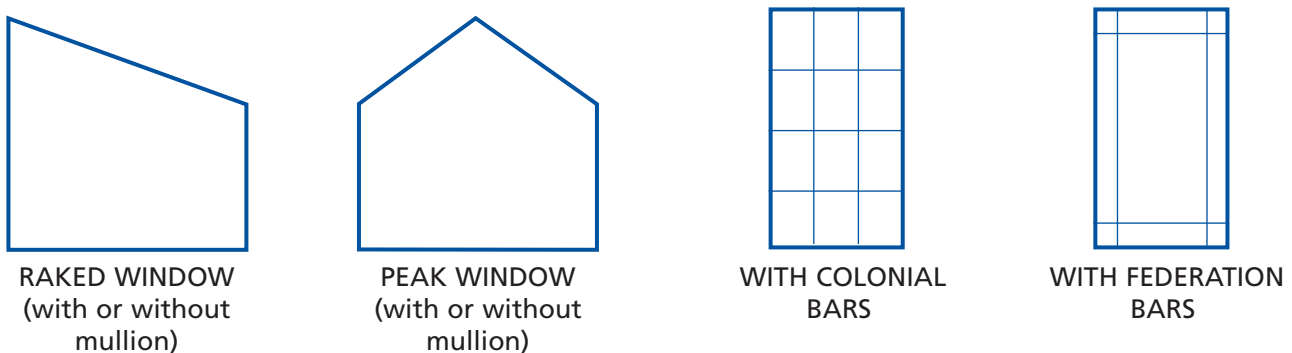

#### Note:

- When ordering, always state the height dimension first.
- All configurations are viewed from the outside looking inside.
- The above can be mixed to achieve other possible configurations.
- The availability of certain sizes and configurations is dependent on the design wind load requirement of the site. Check with your G.James Representative to confirm availability.
- A minimum diameter of 600mm (painted frames) and 800mm (anodised frames) applies to circles, semi-circles and arches.
- Drawings may not be to scale.
- Available on request (additional charges apply):
  - Timber reveals: finger joint pine (FJP), primed FJP, clear pine, meranti and LOSP treated types are available. When ordering nominate reveal type and width required.
  - Security, acoustic and energy efficient upgrades.
  - Non-standard sizes.
  - Colonial or federation style bars.

# 136 Series Double Hung Window

## STANDARD SIZE RANGE

		Stud Opening with Reveal (Includes 10mm Clearance)							
		Aluminium Frame Size							
		WIDTH							
		660	960	1260	1560	1860	2160	2460	2760
		610	910	1210	1510	1810	2110	2410	2710
HEIGHT	950								
	1250								
	1550								
	1850								
	2150								

### Note:

- All dimensions stated are in millimetres.
- All aluminium frame sizes detailed above refer to the outer frame dimensions of the window exclusive of the fixing fin.
- Due to weight limitations on various operating components, sizes which exceed the standard size range may not be available. Check with your G.James Representative to confirm availability.
- Multiple bay configurations will be supplied in equal splits unless requested otherwise.
- For windows 1800mm and over, it is recommended to consider the operation of the window to ensure the configuration selected is the best 'fit-for-purpose'. Issues such as reach, sash weight and furniture location are some aspects that can affect the ability to open and close a double hung window. The option of selecting a counter balance operation in such situations should also be considered.
- Where a choice of configuration for a particular width is illustrated above, the customer is to nominate the number of bays required.
- Single bay windows over 1000mm in width will be fitted with two (2) catches as standard.
- Spring-balance type operation is supplied as standard unless counter-balance type is requested.
- Black hardware is supplied as standard.
- The availability of certain sizes and configurations is dependent on the design wind load requirement of the site. Check with your G.James Representative to confirm availability.
- Drawings may not be to scale.
- Available on request (additional charges apply):
  - Timber reveals: finger joint pine (FJP), primed FJP, clear pine, meranti and LOSP treated types are available. When ordering nominate reveal type and width required.
  - Security, acoustic and energy efficient upgrades.
  - Non-standard sizes.
  - Colonial or federation style bars.

# 136 Series Double Hung Window

STANDARD SIZE RANGE (WITH FIXED LIGHT OPTION)

		Aluminium Frame Size						
		1260	1560	1860	2160	2460	2760	3060
HEIGHT	950							
	1050							
1250								
1550								
1850								
2150								

**Legend**

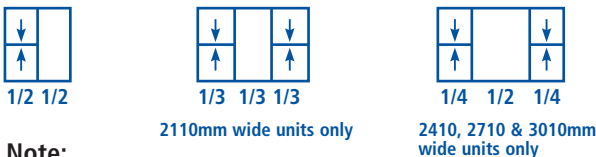

**Note:**

- All dimensions stated are in millimetres.
- When ordering, always state the height dimension first.
- All aluminium frame sizes detailed above refer to the outer frame dimensions of the window exclusive of the fixing fin.
- Due to weight limitations on various operating components, sizes which exceed the standard size range may not be available. Check with your G.James Representative to confirm availability.
- For windows 1800mm and over, it is recommended to consider the operation of the window to ensure the configuration selected is the best 'fit-for-purpose'. Issues such as reach, sash weight and furniture location are some aspects that can affect the ability to open and close a double hung window. The option of selecting a counter balance operation in such situations should also be considered.
- Splits for multiple bay configurations will be supplied as per the above 'Legend' unless requested otherwise.
- Where a choice of configuration for a particular width is illustrated above, the customer is to nominate either a two or three bay unit.

- Windows over 1000mm in width will be fitted with two (2) catches as standard
- Black hardware is supplied as standard.
- Spring-balance type operation is supplied as standard unless counter-balance type is requested.
- The availability of certain sizes and configurations is dependent on the design wind load requirement of the site. Check with your G.James Representative to confirm availability.
- Drawings may not be to scale.
- Available on request (additional charges apply):
  - Timber reveals: finger joint pine (FJP), primed FJP, clear pine, meranti and LOSP treated types are available. When ordering nominate reveal type and width required.
  - Security, acoustic and energy efficient upgrades.
  - Non-standard sizes.
  - Colonial or federation style bars.

# 136 Series Double Hung Window

## POSSIBLE CONFIGURATIONS

With Low Light

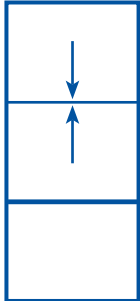

With Split Semi-Circle Head

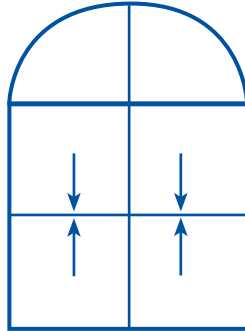

Coupled to Sliding Door

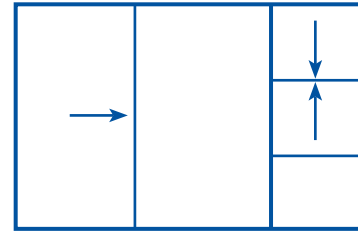

Side light can be coupled to fixed panel side only

With Colonial Bars

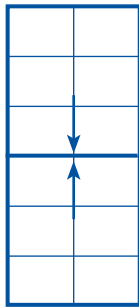

With Federation Bars

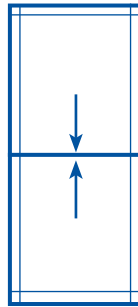

With Federation Bars

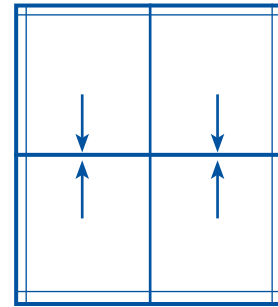

# 136 Series Bay Window

## POSSIBLE CONFIGURATIONS

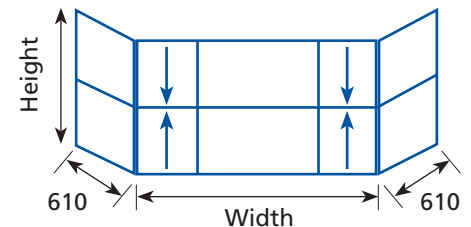
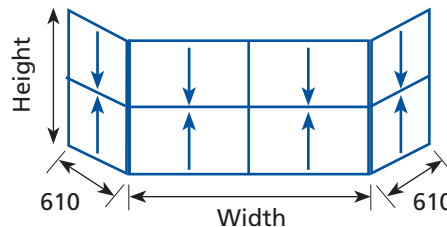
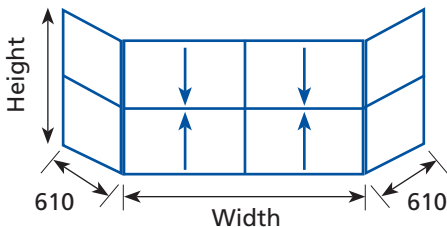

### Note:

- All dimensions are to be stated in millimetres.
- When ordering, always state the height dimension first.
- When ordering, state the outer frame dimensions exclusive of the fixing fin.
- Due to weight limitations on various operating components, sizes which exceed the standard size range may not be available. Check with your G. James Representative to confirm availability.
- Multiple bay configurations will be supplied in equal vertical splits unless requested otherwise. This excludes three (3) bay double-hung units which will be split as per page 12. Customer to nominate all horizontal splits.
- Black hardware is supplied as standard.
- Drawings may not be to scale.
- Other configurations may be available upon request. The availability of certain sizes and configurations is dependent on the design wind load requirement of the site. Check with your G. James Representative to confirm availability.
- Available upon request (additional charges apply):
  - Timber reveals: finger joint pine (FJP), primed FJP, clear pine, meranti and LOSP treated types are available. When ordering nominate reveal type and width required.
  - Security, acoustic and energy efficient upgrades.
  - Colonial and federation style bars.



## PRODUCT RANGE

### FLYSCREENS

**Hinged Flyscreen Door**  
(Manufactured to suit opening)

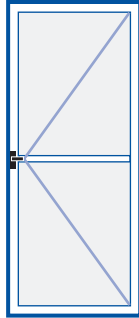

HF

### BARRIER SCREENS

**Hinged Barrier Screen Door**  
(Manufactured to suit opening)

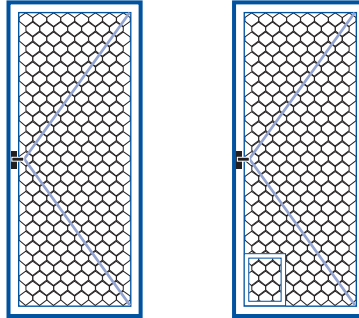

HS

HSD

### CRIMSAFE™ SCREENS

**Hinged Crimsafe Door**  
(Manufactured to suit opening)

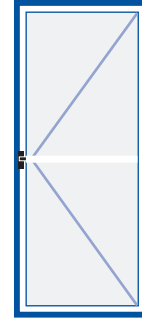

HF

**Sliding Flyscreen Door**  
(Manufactured to suit  
245 Series Sliding Doors)

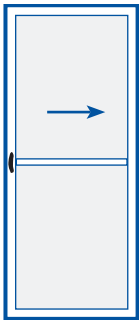

DF

**Sliding Barrier Screen Door**  
(Manufactured to suit  
245 Series Sliding Doors)

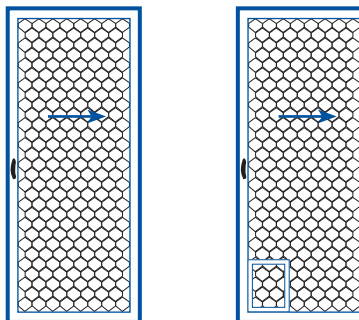

DS

DSD

**Sliding Crimsafe Screen Door**  
(Manufactured to suit  
245 Series Sliding Doors)

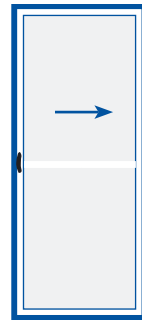

DF

**Fixed Flyscreen**  
(Manufactured to suit 048, 050,  
131 & 136 Series Windows)

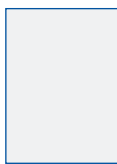

WF

**Fixed Barrier Screen**  
(Manufactured to suit 048, 050,  
131 & 136 Series Windows)

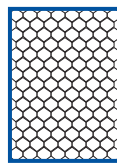

WS

**Fixed Crimsafe Screen**  
(Manufactured to suit 048 awning,  
050, 131 & 136 Series Windows)



WF

**Note:**

- All flyscreens are supplied with fibreglass mesh as standard. Aluminium mesh is available upon request.
- Midrail and handle heights is dependent on customer requirements and the position of any internal door hardware.
- Black hardware is supplied as standard.
- Drawings may not be to scale.

**Note:**

- All barrier screens incorporate 7mm ArmaGrille (Security Mesh) and self latching keylock handles (doors only).
- Hinged barrier screens can be upgraded to comply with Australian Standards (AS 2803 – 1994) upon request.
- Handle heights is dependent on customer requirements and the position of any internal door hardware.
- HSD and DSD types illustrate a barrier door with a top-hinged, dual action pet door.
- It is recommended that a qualified installer fit barrier screens and doors.
- Black hardware and black anodised ArmaGrille are supplied as standard.
- Drawings may not be to scale.

**Note:**

- Handle height is dependent on customer requirements.
- The specification for this product requires a midrail be fitted to Crimsafe screens which exceed certain size parameters.
- Maximum Crimsafe screen width 1550mm.
- It is recommended that a qualified installer fit Crimsafe screens.
- Black hardware is supplied as standard
- Drawings may not be to scale.
- Crimsafe is a registered trademark of Crimsafe Security Systems Pty Ltd.

# 245 Series Sliding Door

## STANDARD SIZE RANGE

Stud Opening with Reveal (Includes 10mm Clearance)

Aluminium Frame Size

WIDTH

HEIGHT

HEIGHT	1560	1860	2160	2460	2760
2130	1510	1810	2110	2410	2710
2100	2729	3179	3629	2771	3221
	2679	3129	3579	2721	3171
	3042	3642	4242	4842	
	2992	3592	4192	4792	
	4478	5378	6278		
	4428	5328	6228		

### Legend

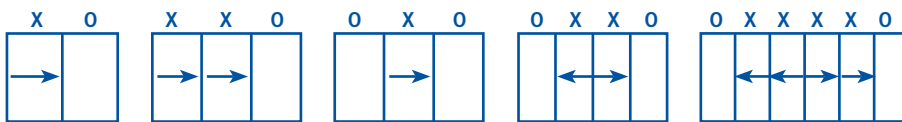

### Note:

- All dimensions stated are in millimetres.
- When ordering, always state the height dimension first.
- All aluminium frame sizes detailed above refer to the outer frame dimensions of the door exclusive of the fixing fin.
- All configurations are viewed from the outside looking inside.
- XO & OX doors can be reversed after installation.
- All sliding panels are positioned on the inner most track(s) with any screens to the outer track(s). This situation may differ for XXO and OXXXXO configurations - check with your G.James Representative.
- The frame size of all 2100mm high doors supplied to N5C3(W60) category sites will be at 2054mm high.
- Sizes up to 2400mm and low profile sill available on request.
- Black hardware is supplied as standard.
- The availability of certain sizes and configurations is dependent on the design wind load requirement of the site - check with your G.James Representative.
- Drawings may not be to scale.
- Available on request (additional charges apply):
  - Timber reveals: finger joint pine (FJP), primed FJP, clear pine, meranti and LOSP treated types are available. When ordering nominate reveal type and width required.
  - Security, acoustic and energy efficient upgrades.
  - Non-standard sizes.

# 245 Series Sliding Door

STANDARD SIZE RANGE – CORNER DOOR CONFIGURATIONS

## Inside Corner

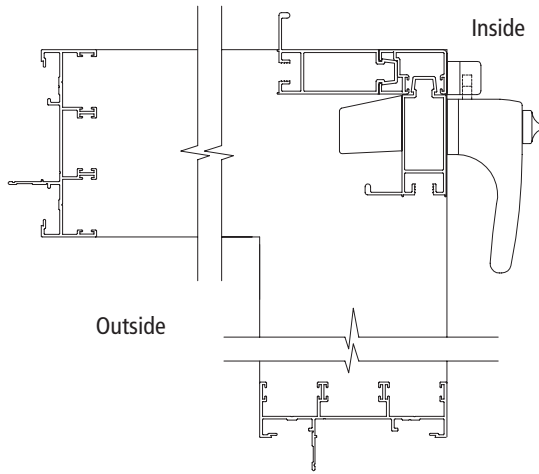

## Outside Corner

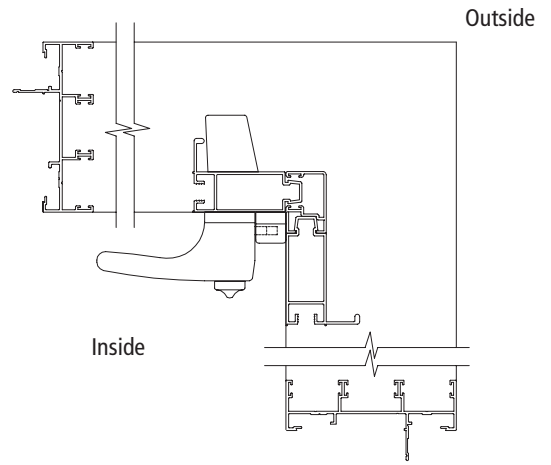

Stud Opening with Reveal (Includes 10mm Clearance)

Aluminium Frame Size

**WIDTH**

**WIDTH**

1484 / 1471

1784 / 1771

1652 / 1639

1952 / 1939

1434 / 1421

1734 / 1721

1602 / 1589

1902 / 1889

2084 / 2071

2384 / 2371

2252 / 2239

2552 / 2539

2034 / 2021

2334 / 2321

2202 / 2189

2502 / 2489

2135 / 2123

2585 / 2573

2437 / 2424

2887 / 2874

2085 / 2073

2535 / 2523

2387 / 2374

2837 / 2824

3035 / 3023

3485 / 3473

3337 / 3324

3787 / 3774

2985 / 2973

3435 / 3423

3287 / 3274

3737 / 3724

HEIGHT

2130

2100

# 245 Series Sliding Door

## POSSIBLE CONFIGURATIONS

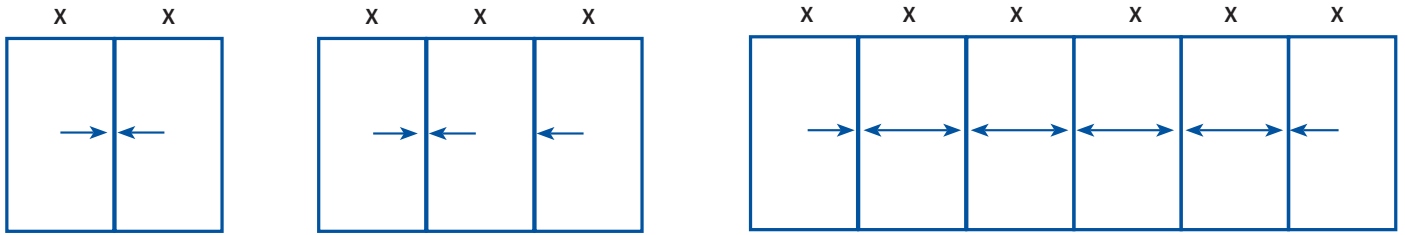

### Corner Door Configurations Available

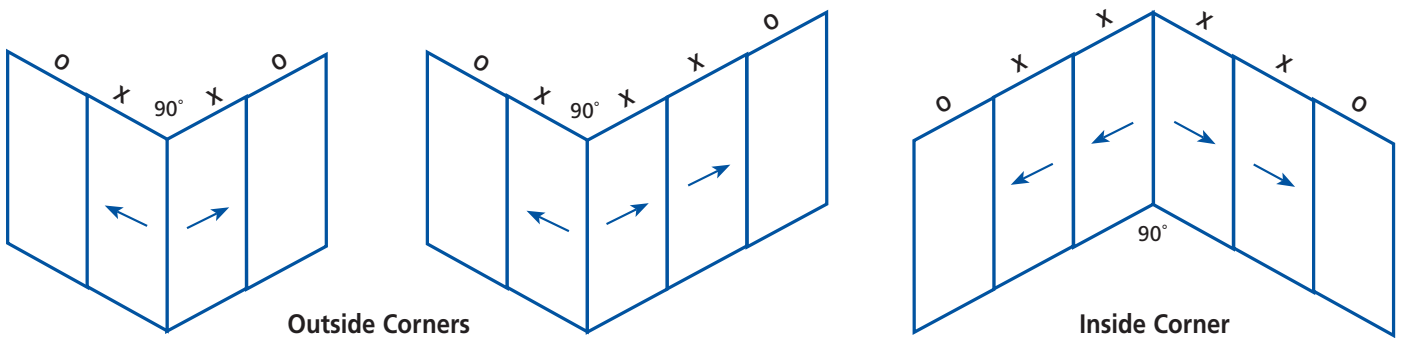

### Coupled to Double Hung Side Light

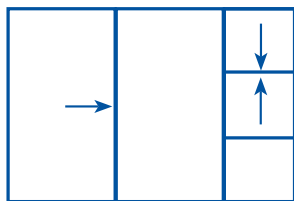

Side light can be coupled to fixed panel side only

### With Fixed High Lights

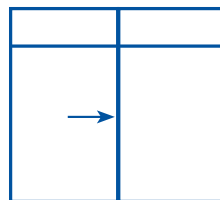

### Coupled to Louvered Side Light

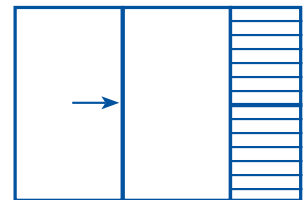

Side light can be coupled to fixed panel side only

### With Colonial Bars

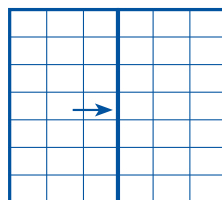

### With Federation Bars

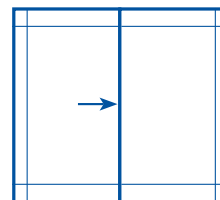

### Note:

- When ordering, always state the height dimension first.
- The availability of certain sizes and configurations is dependent on the design wind load requirement of the site. Check with your G.James Representative to confirm availability.
- All configurations are viewed from the outside looking inside.
- All sliding panels will be positioned to the inner most track / s with screens fitted to the outside track. Conditions apply to the screening and position of the sliding panels for XXO and OXXXXO configurations - check with your G.James Representative.
- Low profile sill and double glazed doors are available on request.

- Elements of the above can be mixed to achieve other configurations.
- Black hardware is supplied as standard.
- Drawings may not be to scale.
- Available on request (additional charges apply):
  - Timber reveals: finger joint pine (FJP), primed FJP, clear pine, meranti and LOSP treated types are available. When ordering nominate reveal type and width required.
  - Security, acoustic and energy efficient upgrades.
  - Non-standard sizes.

# 245 Series Sliding Door

## POSSIBLE CONFIGURATIONS – FIVE (5) TRACK SYSTEM

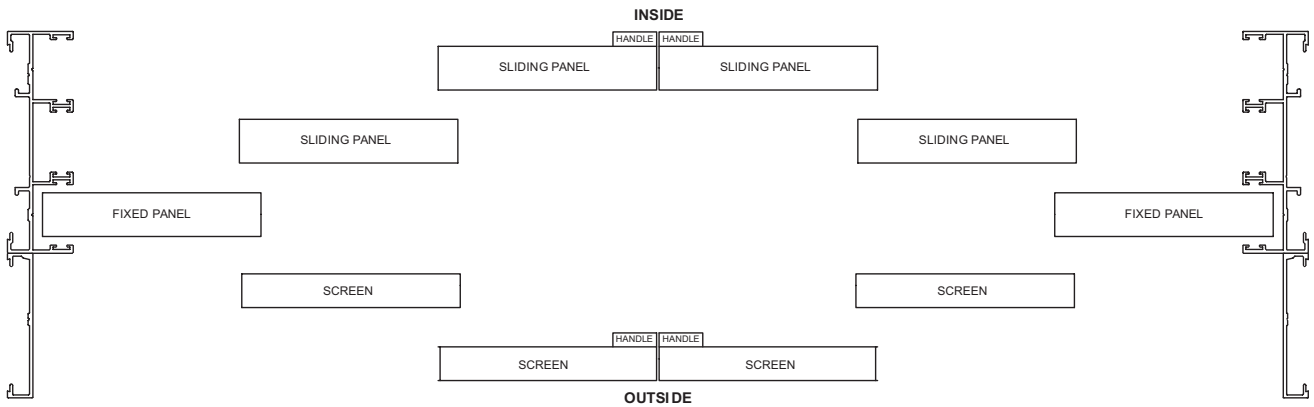
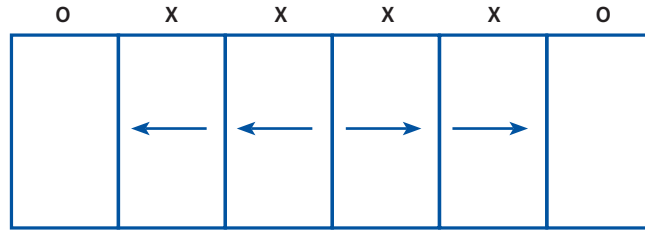

**OXXXXO SLIDING DOOR WITH SCREENS FITTED  
(PLAN VIEW, PANEL LAYOUT ONLY)**

Drawings may not be to scale

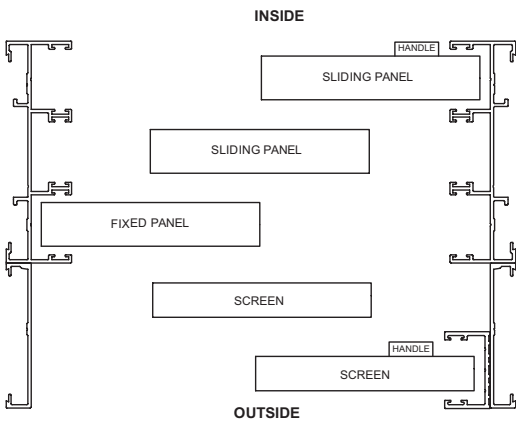
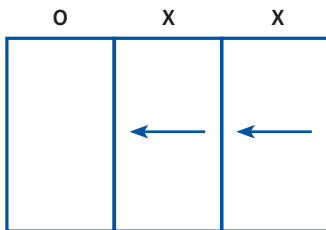

**OXX SLIDING DOOR WITH SCREENS FITTED  
(PLAN VIEW, PANEL LAYOUT ONLY)**

Drawings may not be to scale

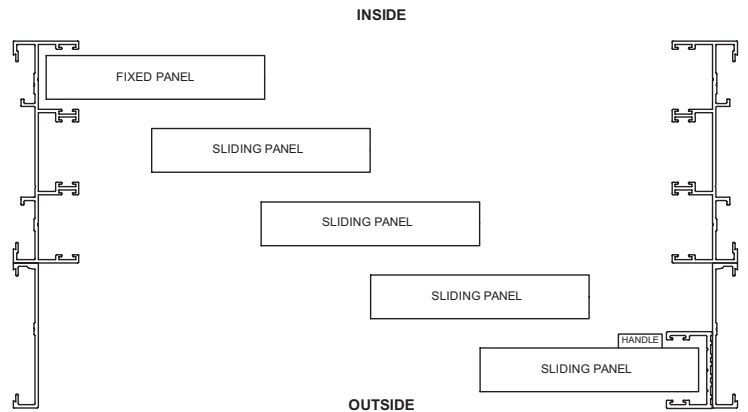
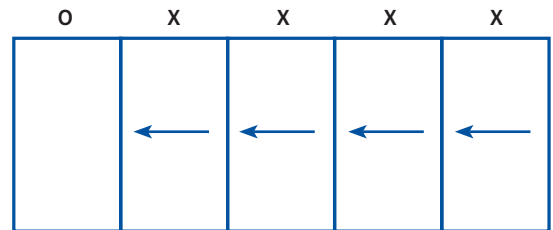

**OXXXX SLIDING DOOR  
(PLAN VIEW, PANEL LAYOUT ONLY)  
\* NO SCREENING POSSIBLE WITH THIS CONFIGURATION**

Drawings may not be to scale

# 470 & 474 Series Hinged Doors

## SIZE RANGE

Aluminium Frame Size		WIDTH								
		800	960	1260	1560	1860	2160	2460	2760	3060
HEIGHT	2130 – 2430									
	2100 – 2400									

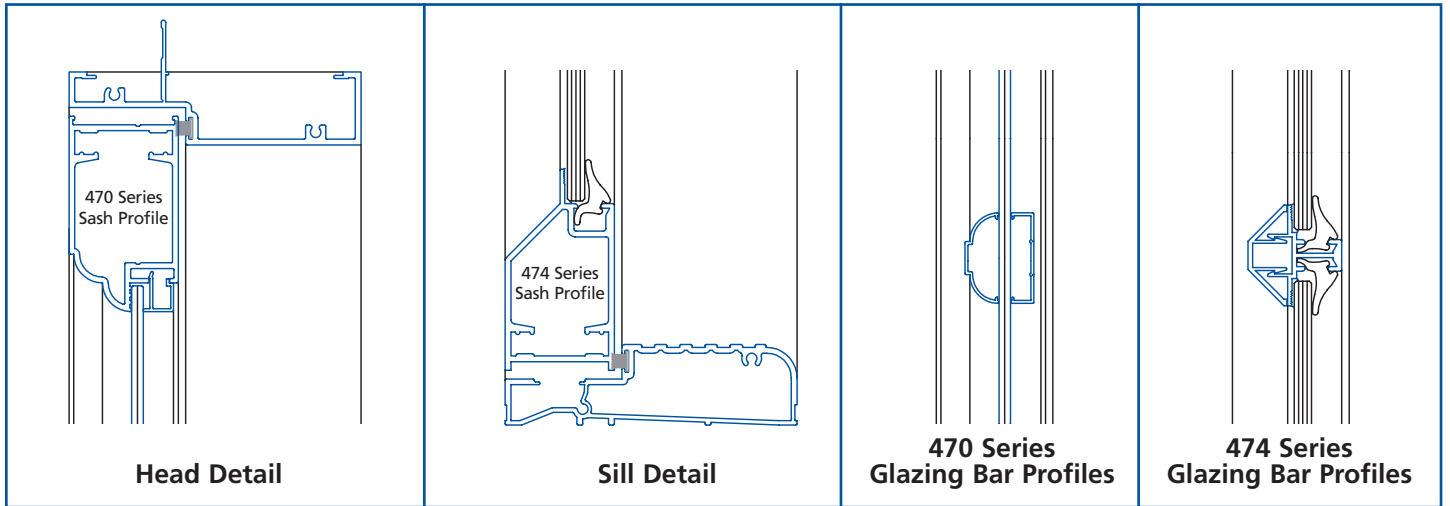

## POSSIBLE CONFIGURATIONS

With Flat Colonial Bars  
(Instead of 470/474 Series Glazing Bars)

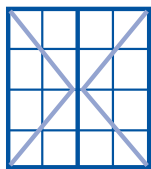

With Federation Bars  
(Instead of 470/474 Series Glazing Bars)

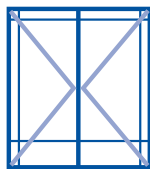

With High Lights

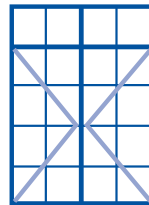

No Bars with High Lights

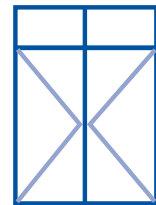

### Note:

- All dimensions are stated in millimetres.
- When ordering, state the height dimension first.
- When ordering, state the outer frame dimensions exclusive of the fixing fin.
- All configurations are viewed from the outside looking inside.
- Multiple leaf configurations will be supplied in equal vertical splits unless requested otherwise.
- Handles are available in powder coat, satin chrome or polished brass - customer is to nominate at time of order. It should be noted the polished brass coating can be damaged as a result of everyday use (eg. scratching with keys, rings etc.) causing the handle to tarnish. If this tarnishing causes concern G. James recommends an alternative finish be specified.
- It is recommended the 470 & 474 Series door be installed in protected or semi-sheltered locations only.
- The standard bar setout is three (3) horizontal (ie. four (4) divisions) and one (1) vertical (ie. two (2) divisions) unless requested otherwise. In some instances, the vertical bar may be deleted if a leaf is deemed too narrow.
- Other configurations may be available upon request. The availability of certain sizes and configurations is dependent on the design wind load requirement of the site. Check with your G. James Representative to confirm availability.
- Drawings may not be to scale.
- Available upon request (additional charges apply):
  - Timber reveals: finger joint pine (FJP), primed FJP, clear pine, meranti and LOSP treated types are available. When ordering nominate reveal type and width required.
  - Tinted glass.



# 472 Series Hinged Door

## POSSIBLE CONFIGURATIONS

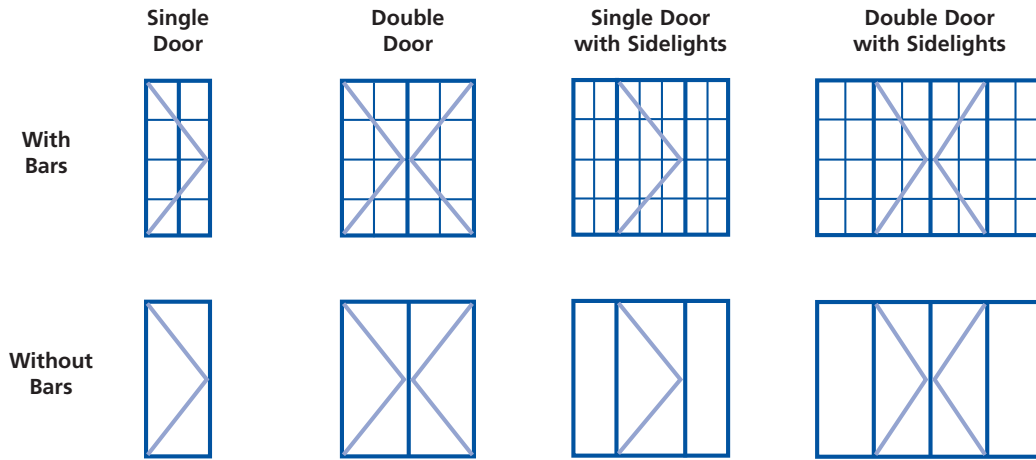

### OUTWARD OPENING CONFIGURATION - 101mm Frame

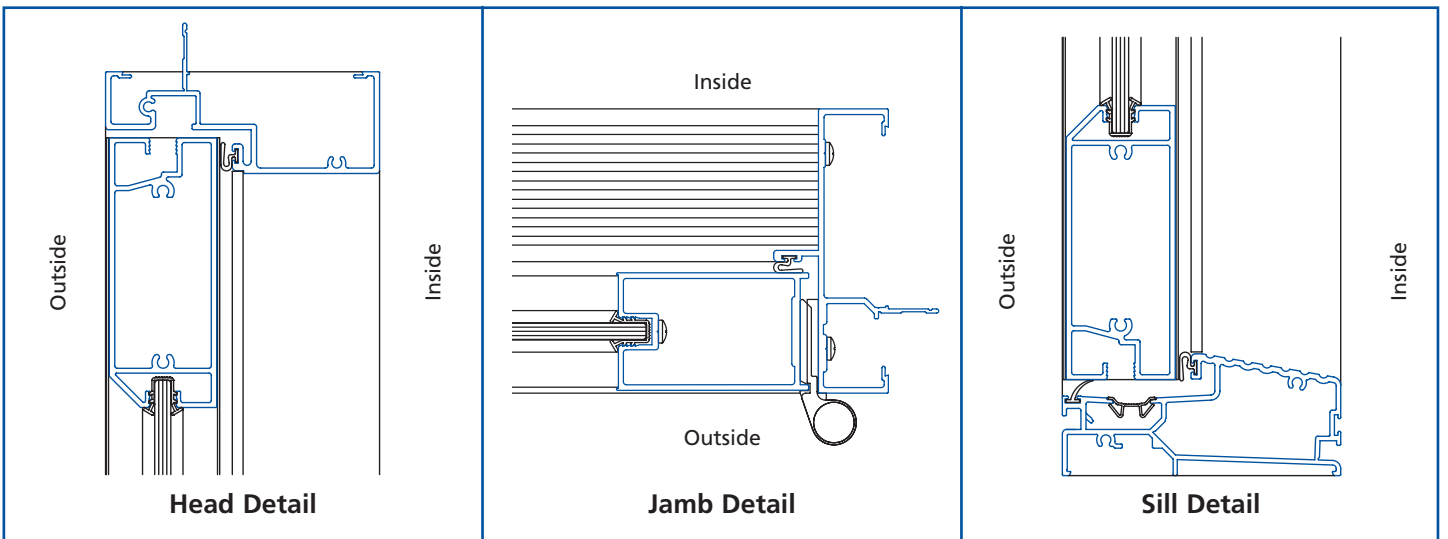

### INWARD OPENING CONFIGURATION - 125mm Frame (WITH BARRIER SCREEN)

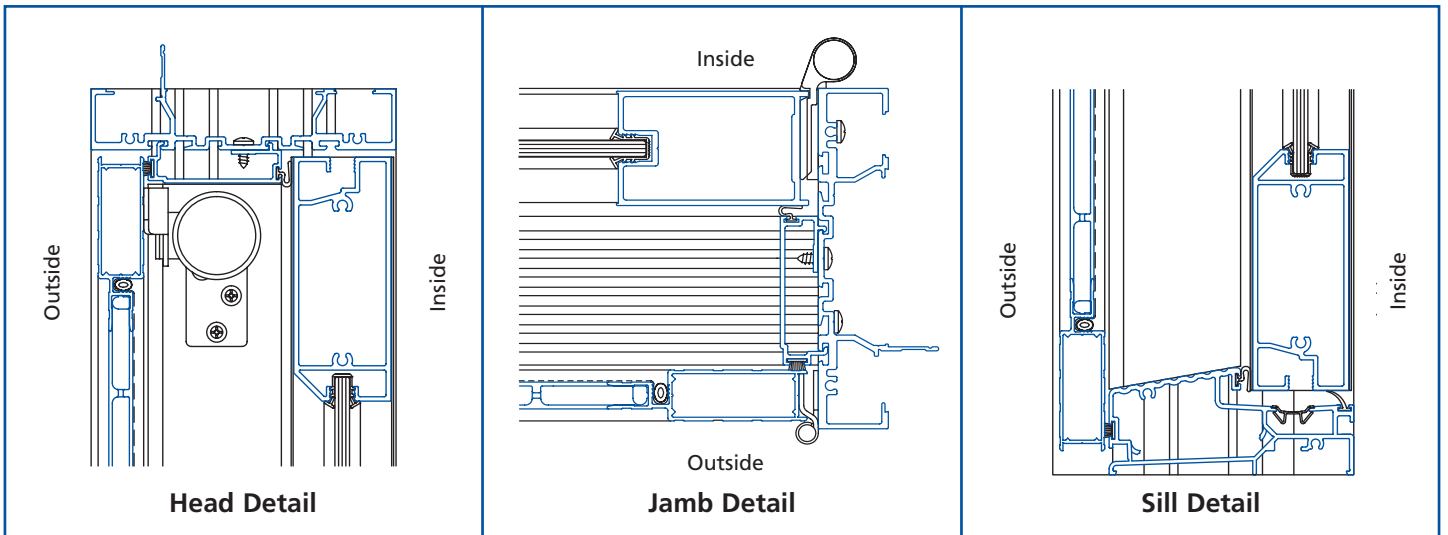

\*Diagrams are for illustrative purposes only and may not be drawn to scale.

## POSSIBLE CONFIGURATIONS

2 Leaf

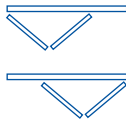
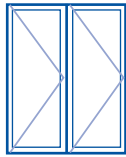

3 Leaf

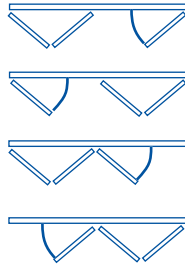
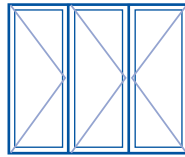

4 Leaf

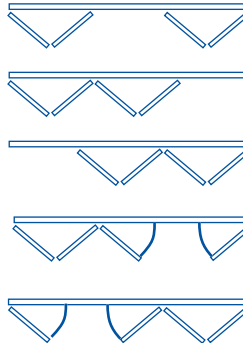
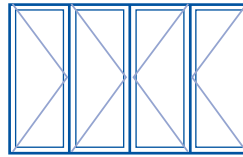

5 Leaf

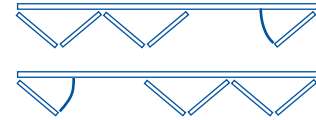
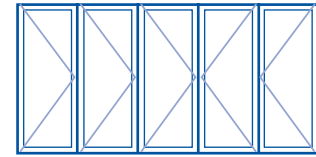

6 Leaf

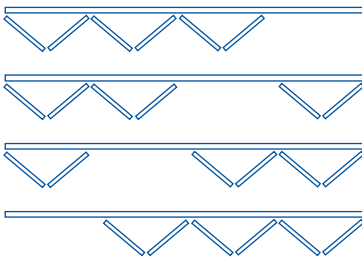
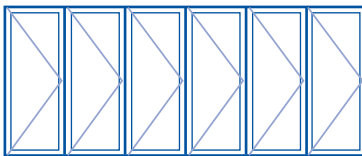

8 Leaf

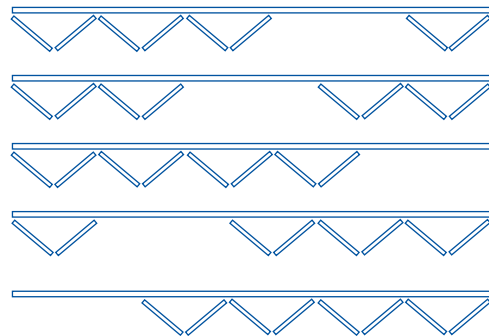
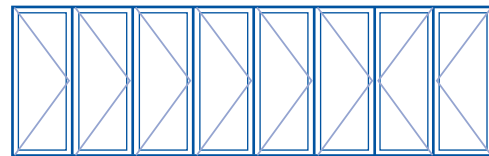

- Screening a Bi-fold Door is now possible with the new 140 Series Roller Screen (internally fitted)
- Bi-fold Windows for servery and window seat applications are also available.

### Note:

- When ordering always state the height first.
- All configurations are viewed from the outside looking inside.
- The availability of certain sizes and configurations is dependent on the design wind load requirement. Confirm availability with your G.James Representative.
- Consult your G.James Representative to determine the most suitable configuration for your lifestyle and site conditions.
- Door Leaf Limitations: Not to exceed 2700mm (high), 900mm (wide) or 40kg/leaf. A minimum sash width of 650mm applies. For other sizes contact your G.James Representative.
- Dotted lines in above illustrations indicate a service leaf.
- The elevation drawings above represent the first configuration (shown in plan view) under each leaf type.
- The elevations detail the first opening configuration shown in plan.
- The above opening configurations represent the possible openings for the specific number of leaves illustrated and do not indicate all the opening configurations possible within the single door unit.
- Standard hardware: self latching lever handle with deadlock (in satin chrome) to service leaf and lever operated, two point bolting system (keyed option available upon request) (in black) to other leaves as required.
- As this product is top hung, a structurally supportive head is required (to be supplied by builder).
- Drawings may not be to scale.

# 801 Series Wardrobe Door

## Size Range / Possible Configurations

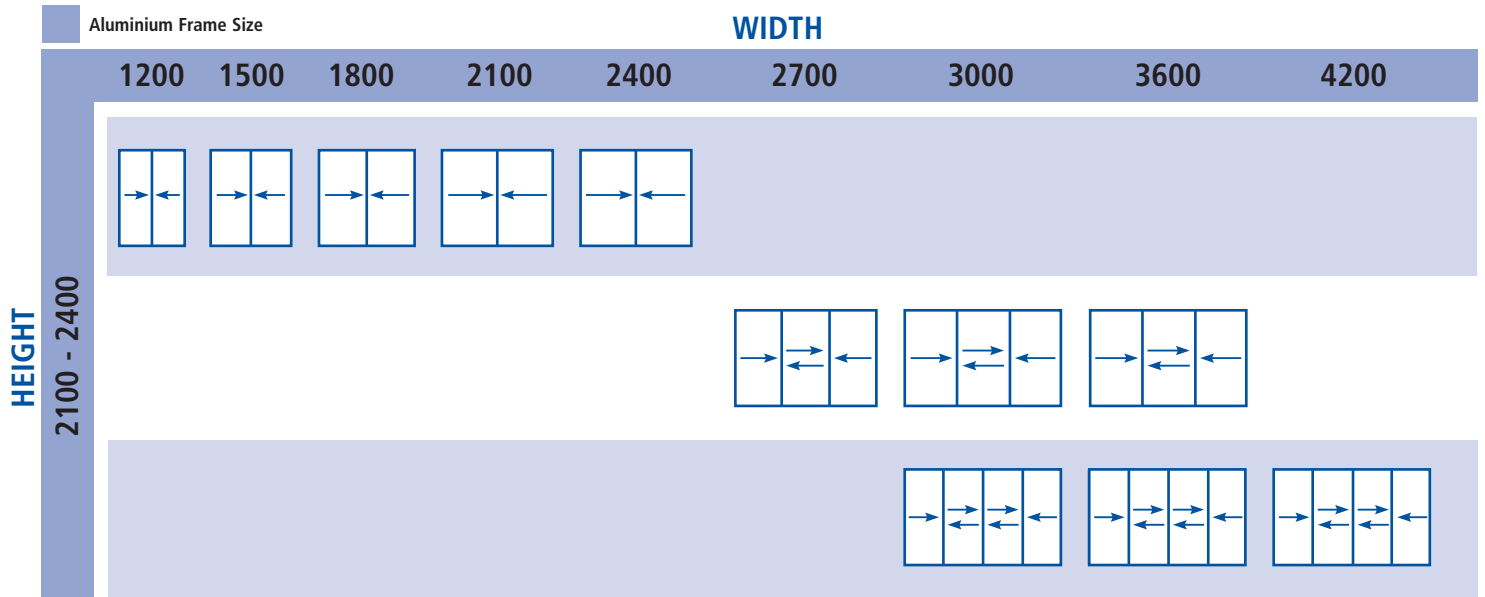

### XX Material Configurations

- M – All panels mirror
- P – All panels lamiwood
- G – All panels plaster board
- F – All panels MDF

- MP – 1 panel mirror, 1 panel lamiwood
- MG – 1 panel mirror, 1 panel plaster board
- MF – 1 panel mirror, 1 panel MDF

### XXX Material Configurations

- M – All panels mirror
- P – All panels lamiwood
- G – All panels plaster board
- F – All panels MDF

- MP – 1 panel mirror, 2 panels lamiwood
- MG – 1 panel mirror, 2 panels plaster board
- MF – 1 panel mirror, 2 panels MDF

### XXXX Material Configurations

- M – All panels mirror
- P – All panels lamiwood
- G – All panels plaster board
- F – All panels MDF

- MP – 2 panels mirror, 2 panels lamiwood
- MG – 2 panels mirror, 2 panels plaster board
- MF – 2 panels mirror, 2 panels MDF

### Legend

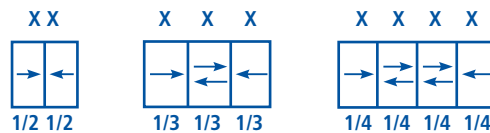

### Note:

- All dimensions stated are in millimetres.
- When ordering always state the height first.
- All aluminium frame sizes detailed above refer to the outer frame dimensions.
- As most wardrobe doors are individually measured to suit the opening, the sizes detailed above are a guide ONLY.
- A black buffer strip is supplied as standard to all doors with the exception of those panels supplied in Powder Coat White and Pearl White where a white buffer will be supplied as standard.

- Mirror panels comprise 4mm vinyl backed silver (mirror).
- Plaster board panels are available in either vinyl coated or raw finishes.
- The sliding direction of the middle panel in XXX configurations can be reversed at any time after installation.
- The above material configurations are a sample ONLY. Any combination of materials is possible.
- Receiving channels are not supplied as standard but are available upon request.
- Drawings may not be to scale.

## Size Range / Possible Configurations

**Legend:**

Codes with a 'SEP' prefix reference 826 Series 'Fully Framed' Shower screens

Codes with a 'SSS' prefix reference 830 Series 'Semi-frameless' Shower screens



SEP300 / SSS300

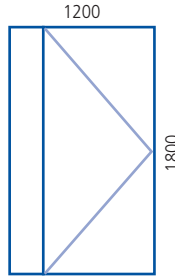

SEP305 / SSS305

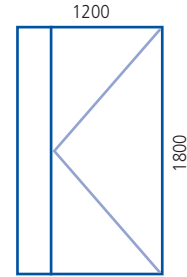

SEP306 / SSS306

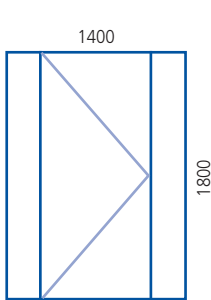

SEP310 / SSS310

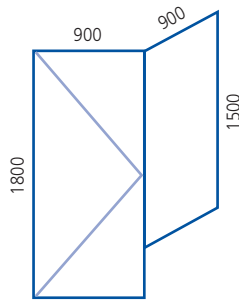

SEP400 / SSS400

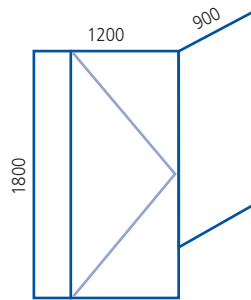

SEP405 / SSS405

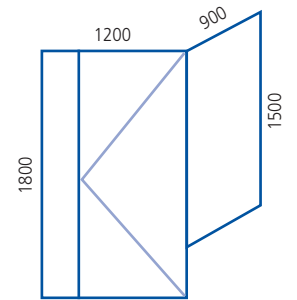

SEP406 / SSS406

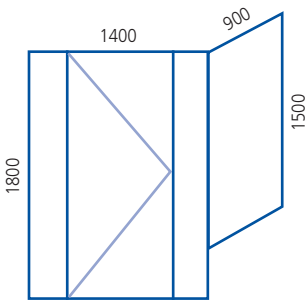

SEP410 / SSS410

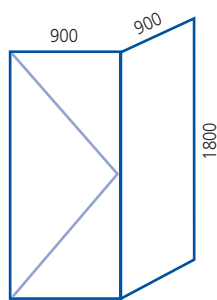

SEP500 / SSS500

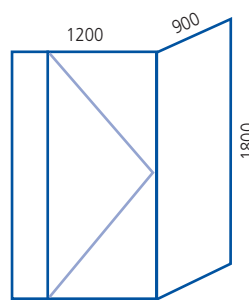

SEP505 / SSS505

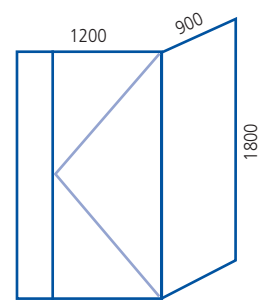

SEP506 / SSS506

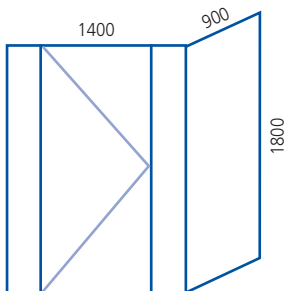

SEP510 / SSS510

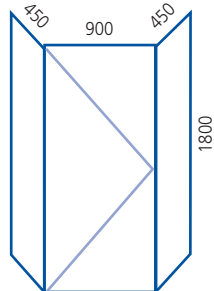

SEP2RS / SSS2RS

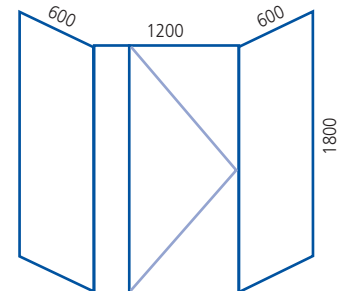

SEP2RL / SSS2RL

- Semi-frameless and 10mm fully frameless screens are also available. All semi-frameless screens with return panel/s will be supplied in 830 Series (which has aluminium framing to the horizontals and wall channels only).
- Framed and unframed mirrors can also be supplied

**Note:**

- When ordering always state the height first.
- As most showerscreens are individually measured to suit the opening, the sizes detailed above are a guide ONLY.
- It is recommended that all non-full height return panels be installed to the inside below the hob to aid drainage.
- All pivot door sashes will be supplied at a maximum width of 900mm.
- Black hardware is supplied as standard.
- All panels are glazed with a Grade 'A' safety glass.
- A clear sill flap fitted to pivot door (bottom) rail is available upon request.
- Reverse handing to that shown above is available.
- Drawings may not be to scale.

## Size Range / Possible Configurations

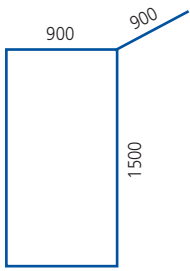

SES100

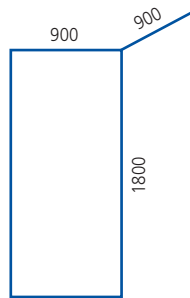

SES200

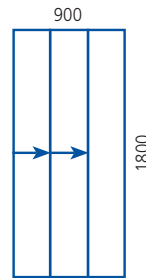

SES300

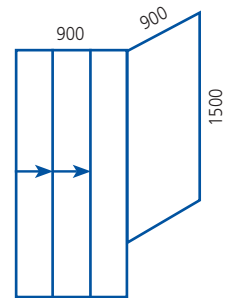

SES400

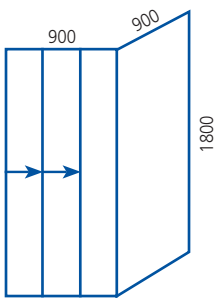

SES500

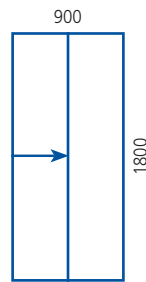

SES600

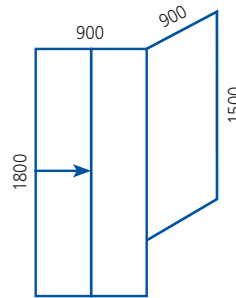

SES700

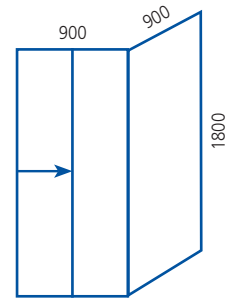

SES800

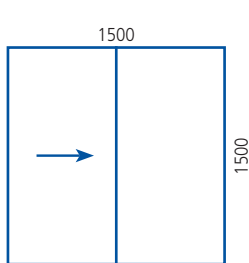

SES900

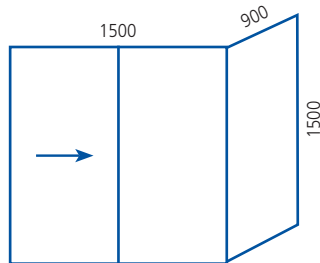

SES905

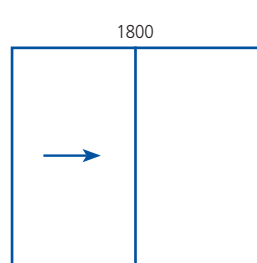

SES950

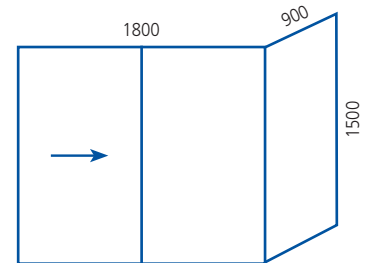

SES955

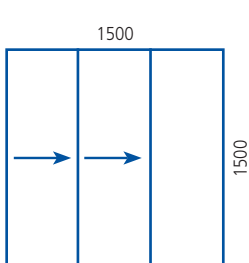

SES1000

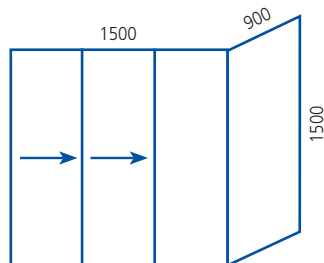

SES1005

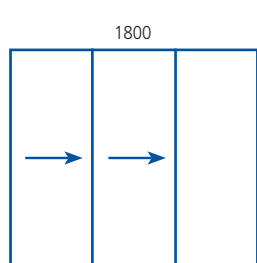

SES1050

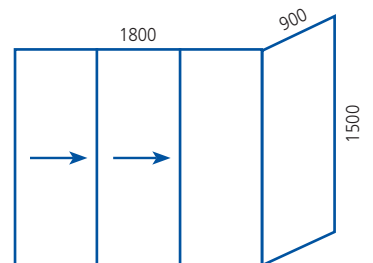

SES1055

- Framed and unframed mirrors can also be supplied

**Note:**

- When ordering always state the height first.
- Reverse handing to that shown above is available.
- As most showerscreens are individually measured to suit the opening, the sizes detailed above are a guide ONLY.
- It is recommended that all non-full height return panels be installed to the inside below the hob to aid drainage.
- Black hardware is supplied as standard.
- All panels are glazed with a Grade 'A' safety glass.
- Drawings may not be to scale.

**Acoustics:** The science of sound and sound control.

**Anodising:** A surface finish applied through an electrolysis process resulting in a hard, corrosion resistant oxide film.

**ArmaGrille:** Expanded aluminium security grille. ArmaGrille is a registered trade name of G. James Australia Pty. Ltd.

**Awning Window:** A window where the sash is 'top-hung' allowing it the hinge horizontally at the top and arcs outwards at the bottom.

**Bay Window:** A unit combining a series of windows that protrude externally from the interior wall at either 45° or 90° angles.

**Bi-fold Door:** A door unit consisting of a number of hinged panels that fold in progression, stacking to one or both sides of the door opening.

**Casement Window:** A window where the sash is 'side-hung' with friction stays allowing it the hinge vertically from one side and arc outwards from the opposite side.

**Chainwinder:** A hardware item used to open and close awning windows. It consists of a winding mechanism and a semi-rigid chain which is attached to the bottom rail of the sash. As the winder is operated, the sash either extends or retracts depending on the winding direction.

**Colonial Bars:** A grid-like decorative feature created by a combination of horizontal and vertical aluminium flat bars (19mm wide) siliconed to both sides of a glass panel. As a guide, spacings between the bars are at 250 - 300mm or as deemed appropriate for the size of the panel.

**Counter-balance Double-hung Window:** A window in which both the top and bottom sashes operate simultaneously.

**Dampcourse:** A durable material fixed to the perimeter frame of windows and doors which at the time of installation is placed in the wall of a house to divert the course of any moisture.

**Double Glazing:** Refers to the use of either a mechanically-sealed double-glazed unit (see *Insulated Glass Unit*) or two (2) individually glazed panels of glass which are spaced apart to achieve an improved level of acoustic and/or thermal performance. For acoustic purposes, increasing the space between the glass and/or increasing the glass thickness or type will improve the acoustic performance, similarly the thermal performance can be improved by altering the types of glass(es) in the configuration.

**Double-hung Window:** A window in which the sashes slide in a vertical direction (available with spring-hung or counter-balance operation).

**Fixed Window:** A window in which there is no opening sashes.

**Fixed Vent:** A small area at the top of a sliding sash glazed with an aluminium mesh to provide a means of permanent ventilation.

**Fixing Fin:** A protrusion from the frame members (head, sill (not in doors) & jamb) used to fix a reveal to the perimeter frame of a window or door.

**Flashing:** A metal or PVC strip attached to the perimeter of a window or door and, once installed, used to divert any water to the exterior, common in brick veneer applications.

**Frame:** The joined assembly (head, sill and jambs) or surround of a window or door.

**Friction Stay:** A hardware item used for the fitting and operation of awning and casement sashes. Comprising of either stainless or galvanised steel, these stays use 'friction' to hold the sash in an open position.

**French Style Door:** Incorporates individually glazed panels with sloped or angled type sash and glazing bar profiles (see 474 Series).

**Gasket:** An adhesive PVC tab used in the fabrication of window and door perimeter frames to create a seal at the frame corners.

**Glazing Vinyl / Wedge:** A flexible PVC extrusion used to retain glass in a sash or frame.

**Glazing Bead:** A separate aluminium profile used to retain glass within a frame.

**Handing:** In casement windows and single hinged doors, this refers to the side (either left or right) on which the handle is mounted as viewed from the outside.

**Head:** The top horizontal frame member of a window or door.

**Heat Loss:** The transmission or radiation of interior heat to the outside through glazed areas.

**High Light:** Any window configuration coupled or fixed above a larger sized window or door.

**Hopper Window:** See *Awning Window*.

**Insulated Glass (I.G.) Unit:** Where two or more panes of glass are separated by an air space and then sealed with silicone to form a single, airtight panel of glass. The air space can be filled with either dry air or an inert gas (eg. argon). See also *Double Glazing*.

**Jamb:** The vertical frame members of a window or door.

**Laminated Glass:** Two or more panels of glass permanently bonded together with one or more interlayer(s) of PVB (polyvinyl butyral). If broken, the resulting fragments typically remain intact, firmly adhered to the interlayer. Laminated glass qualifies as a Grade 'A' safety glass suitable for glazing entry doors and accompanying side lights, bathroom windows and shower screens.

**Louvre Window:** A window in which a series of horizontal overlapping 'blades' (comprising glass, aluminium and / or timber) are retained within a gallery of moulded clips. The blades pivot via the operation of a handle(s) which allows the blade angle to be adjusted.

**Low Light:** Any window configuration coupled or fixed below a larger sized window.

**Motif:** A visual design either adhered onto or etched into a glass panel used to draw attention to, and minimise collisions with a closed door.

**Mullion:** The vertical member(s) of a window or door used to create divisions and support the glass within the perimeter frame, and can constitute either a fixed or movable part of the unit. The combined strength of any mullion configuration is critical in satisfying the design wind load for a particular site.

**Obscure Glass:** A type of patterned glass extensively use for light control, bathrooms and decorative glazing applications.

**Powder Coating:** A durable and decorative surface finish applied to the aluminium.

**Rail:** The horizontal components of a sash.

**Reveal:** A timber surround used for fixing a window or door into the wall framing. A reveal is attached to the window or door frame through a 'fixing fin'. The depth of the reveal is dependent on the construction type. Typical examples are as follows:

- (1) Brick Veneer Reveal Width (mm) = (Internal Sheet Thickness + Stud Width + Cavity Width) less 15mm.
- (2) Clad Sheet Reveal Width (mm) = (Internal Sheet Thickness + Stud Width) less 3 to 5mm.

**Sash:** The assemblies which carry the glass within a window frame and may be fixed or operate by sliding or pivoting actions.

**Safety Glass:** See *Laminated* or *Toughened Glass*.

**Side Light:** A window configuration coupled or fixed to the side(s) of a window or door.

**Sill:** The bottom horizontal frame member of a window or door frame.

**Sill Inlay:** A rigid PVC strip inserted in the sill of windows to close-off the recess in the sill (making cleaning easier) and act as a baffle in the event of extreme water penetration.

**Sliding Door/Window:** A door/window with panels that move (slide) horizontally along a track.

**Solar Heat Gain:** Directly transmitted and absorbed solar energy that enters a buildings interior through glazed areas.

**Stacker Door:** Describes a door operation where the panels, when fully opened, gather or 'stack' at the side (or sides) to maximise the openable area. As this term can refer to either a stacker 'sliding' door (245 Series) or a stacker 'bi-fold' door (477 Series), the customer is to nominate the Series (245 or 477) or stacker product ('slider' or 'bi-fold') at the time of order.

**Standard Size:** Sizes deemed to cover a large proportion of the window and door openings used throughout the building industry.

**Stile:** The vertical components of a sash.

**Stud Opening:** The opening created in timber wall frames to accommodate the window or door with reveals fitted.

**Tinted Glass:** Glass used to reduce solar transmission to the interior by absorbing solar energy, the majority of which is subsequently dissipated to the outside by re-radiation and convection.

**Toughened Glass:** Glass that has been heat treated to induce a high surface and/or edge compression. If broken toughened glass will fracture into many small pieces minimising the extent of injury. Toughened glass qualifies as a Grade 'A' safety glass suitable for glazing entry doors and accompanying side lights, bathroom windows and showerscreens.

**Transom:** The horizontal member(s) of a window or door used to create divisions within the perimeter frame, and can constitute either a fixed and/or movable part of the unit. The combined strength of any transom configuration is critical in satisfying the design wind load for a particular site.

**Window Energy Rating Scheme (WERS):** See page (iv).

**Wind Load:** The forces a building or glazed area is subject to due to wind pressure.

**Window Ventlock:** A keyed device fitted to the bottom of a sliding window sash which allows the sash to be securely locked in a 'venting' position (ie. open at a maximum 100mm) while also providing a secondary method of locking when closed.

**Window Wall:** A combination unit incorporating a series of sliding windows or sliding and fixed windows which are coupled or fixed together to form a 'wall'.

## Maintenance of Glass

All glass surfaces should be kept clean by prompt removal of all dirt and deposits. Clean water should be used and in some instances the addition of a small amount of mild detergent would be of some benefit. Thoroughly wash off any detergent residue with clean water. Do not under any circumstances use any form of abrasive cleaner as this may cause damage to the glass. Lightly sponge off any stubborn dirt being careful not to scratch the glass.

G.James Solect® and Optilight® glass products feature an exposed Low E (or metal based) coating which requires appropriate care when cleaning. For the recommended cleaning instructions relating to these products please contact your G.James representative or visit [www.gjames.com.au/product/gl/cleaning](http://www.gjames.com.au/product/gl/cleaning). Frequency of cleaning should be similar to that specified for powder coated surfaces (see below).

## Maintenance of Powder Coated & Anodised Aluminium

Cleaning is necessary if the fine finish of powder coated and anodised aluminium is to be preserved. Deterioration of the coating occurs mainly as a result of grime deposition and attack by contaminated moisture which in coastal and pool environments contain salt and sulphur compounds.

Deposited grime and contamination absorbs moisture like a sponge and holds it against the powder coated and anodised surfaces. This permits the attack to proceed thereby damaging the coating which cannot be restored.

### Frequency of Cleaning

Cleaning required is dependant on the severity of the environment.

#### Rural / Suburban Environments

The maximum period between cleaning should never be more than six (6) months.

#### Coastal / Pool / Industrial Environments

More frequent cleaning is necessary and the maximum period between cleaning should never be more than three (3) months. Under the worst conditions involving heavy grime deposition and atmospheric pollution (e.g. sulphur compounds or salts) more frequent cleaning is advisable e.g. monthly if deterioration of the coating is to be prevented. The cleaning of powder coated and anodised material should be performed using hand-cleaning and rinsing techniques. This should be achieved by using small amounts of clean

water and recommended cleaning products. Do not under any circumstances use an abrasive type cleaning agent as this will severely damage the surface of the material. Thoroughly rinse off any detergent with clean water. Hosing must be avoided under all circumstances. Dry preferably with a chamois, or alternatively, a soft cloth.

The cleaning of the product should be performed at a time that will allow the aluminium to dry quickly, preferably early in the morning.

We recommend the use of: Kitten 'Glo-Wash', Turtle Wax 'Zip Wash' or RE-PO 'Superwash'. Should these products give less than the desired results Turtle Wax 'Ice Polish' or RE-PO 'Cream Polish' can be used as per the manufacturer's instructions.

**NOTE:** Use only the above mentioned cleaning products. Do not use alternative products by the same or other manufacturers without written authorisation from G.James.

## Maintenance of Hardware

Regular maintenance is required for all hardware, including any stainless steel components. In most environments maintenance is recommended every six (6) months and every three (3) months in coastal, pool and industrial environments.

The internal workings of locks, handles, catches etc. should be kept in good working order by applying a light spray of lubricant similar to WD40 or RP7 into the area(s) of any moving parts.

The external finish of all hardware must be kept clean by removing any harmful residue, especially salt spray, from the surface using a non-abrasive cleaning agent and wiped down with a soft cloth moistened with WD40 or RP7.

When maintaining either internal or external hardware, ensure that all finished surfaces (eg. timber, aluminium etc.) in close proximity are well protected from exposure to any cleaning or lubricating agents.

All tracks and sills must be kept clear of dirt, debris and other matter which can cause damage to, and restrict the proper functioning of rollers, guides and dropbolts.



Thank you for choosing G.James Glass & Aluminium. For your peace of mind, G.James residential windows and doors are proudly guaranteed against defects arising from faulty workmanship or materials for a period of seven (7) years from the invoice date of the goods, subject to the following conditions:

- (a) The product has been installed in accordance with the relevant Australian Standards and recognised building practices.
- (b) The product has been maintained in accordance with the Care and Maintenance Instructions overleaf.
- (c) The product has not been subject to misuse, physical abuse or neglect.
- (d) Manufacturing standards and tolerances are not deemed defects, nor are industry variations in the colour of the aluminium surface finish.
- (e) G.James assumes no liability for damage caused by cleaning solvents or brick cleaning acids.
- (f) This Guarantee is limited to the repair or replacement of the faulty product at the company's discretion but does not extend to the installation or refinishing of a replacement product. No liability is accepted by G.James for personal injury, loss or claim or property damage, installation costs, material or other costs (whether special, consequential or otherwise) howsoever caused or arising whether direct or indirect.
- (g) Only repairs carried out by G.James personnel or authorised G.James agents are covered by this Guarantee.
- (h) Claims under this Guarantee should be made within one month of the defect arising in the product. Copies of documentation showing the purchase date of the product should be included with your written claim and forwarded to the nearest G.James Office.
- (i) This guarantee is in addition to all other rights and remedies in respect of the product to which you are entitled under the Trade Practice Act and similar State and Territory laws.

We are confident our products will perform to, if not exceed your expectations. Should you wish to offer feedback on any of our products or services then please call (07) 38772373 or email [admin@gjames.com.au](mailto:admin@gjames.com.au)



G.James Glass & Aluminium is a member of the Australian Window Association and as such conforms to an Industry Code of Conduct designed to protect consumers



[www.gjames.com.au](http://www.gjames.com.au)

**G. James**  
glass & aluminium



Phone 132 877 for your nearest branch

**Queensland**

**Brisbane**  
30 French St  
Eagle Farm

**Logan City**  
23 Kingston Rd  
Woodridge

**Capalaba**  
176 Redland Bay Rd

**Caboolture**  
40 Sodium St  
Narangba

**Ipswich**  
15 Verrall St  
Riverview

**Gold Coast**  
636 Nerang Rd  
Ashmore

**Toowoomba**  
319 Taylor St

**Sunshine Coast**  
Maroochydore Rd  
Kunda Park

**Gympie**  
6 Bonnick Rd

**Hervey Bay**  
Booral St  
Urangan

**Bundaberg**  
47 Enterprise St

**Gladstone**  
32 Benaraby St

**Rockhampton**  
Featherstone St

**Mackay**  
9 David Muir St  
Slade Point

**Townsville**  
599 Ingham Rd  
Garbutt

**Cairns**  
28 Redden St  
Portsmith

**New South Wales**

**Sydney**  
26 Long St  
Smithfield

**Newcastle**  
65 Pendlebury Rd  
Cardiff

**Taree**  
10 Grey Gum Rd

**Port Macquarie**  
6 Uralla Rd

**Lismore**  
25 Habib St

**Northern Territory**

**Darwin**  
97 Winnellie Rd  
Winnellie

**South Australia**

**Adelaide**  
263 Edinburgh Rd  
Edinburgh