



## Make Eagle Masonry your number one choice for paving and blocks.

Eagle Masonry is a family owned business with 30 years of experience in manufacturing and supplying concrete masonry products to Australian builders, landscapers and developers for a broad range of projects.

Eagle Masonry uses high quality raw materials combined with modern manufacturing methods to provide you with a consistent range of concrete pavers and blocks.

Eagle Masonry pavers and bullnose are manufactured using a method of dry pressing which gives solid and square pavers and bullnoses which are durable, slip-resistant, and easy to maintain. Our pavers are ideal for large and small building and landscaping projects such as footpaths, courtyards, pool surrounds, driveways and walkways.

Eagle Masonry concrete blocks are manufactured using a combination of hydraulic pressing and vibration creating a dense and strong block. The blocks are ideal for both structural load-bearing and non-load-bearing applications.

Eagle Masonry has experience in advising and supplying residential and commercial projects nationally. For more detail see our range specification sheet.

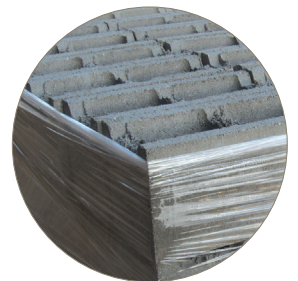

Pavers & bullnoses available in a range of colours



### QUALITY AUSTRALIAN MADE BLOCKS AND PAVING

9 Abbots Road, Dandenong South, VIC 3175  
Phone: 03 9706 4426 Fax: 03 9706 4428 Mobile: 0408 561 598  
Email: rad@eaglemasonry.com.au Web: www.eaglemasonry.com.au

FOR ALL ORDERS AND ENQUIRIES CALL 03 9706 4426

EAGLE MASONRY

## PAVING AND BULL-NOSE FEATURES

- High strength and durability
- High slip resistance
- Easy to install
- Grout between pavers not required
- Dry-pressed (not wet-cast)
- 3mm bevelled edge
- Used for driveways, walkways, patios, and swimming pool surrounds
- Quality checks before dispatch
- All products meet Australian Standard Specifications
- No recycled material used

## COLOUR RANGE

We offer a range of 9 colours to suite every discerning customer. Colours shown may vary slightly from actual product.



Bluestone



Charcoal



Grey



Beige



Light Sandstone



Dark Sandstone



Terracotta

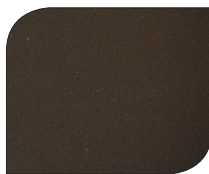

Earth Brown



Tan Brown

## SIZES

*Standard pavers* 400mm x 400mm x 45mm.  
500mm x 500mm x 45mm.

*Bull-nose edged pavers*

500mm x 500mm x 40mm      260mm x 500mm x 40mm  
330mm x 500mm x 40mm      230mm x 500mm x 40mm



### QUALITY AUSTRALIAN MADE BLOCKS AND PAVING

9 Abbots Road, Dandenong South, VIC 3175  
Phone: 03 9706 4426 Fax: 03 9706 4428 Mobile: 0408 561 598  
Email: rad@eaglemasonry.com.au Web: www.eaglemasonry.com.au

FOR ALL ORDERS AND ENQUIRIES CALL 03 9706 4426

EAGLE MASONRY

## BLOCKS

Blocks are available in the 20, 15 and 10 series

- All blocks are manufactured & then tested to AS/NZS 4456.4.
- Quality controlled product

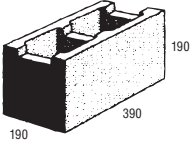
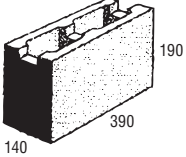
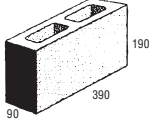
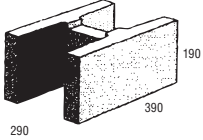
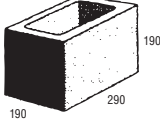
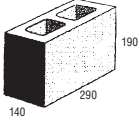
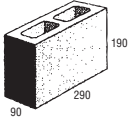
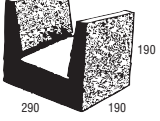
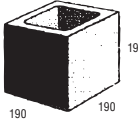
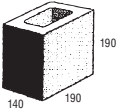
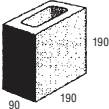
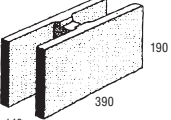
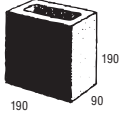
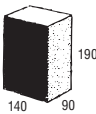
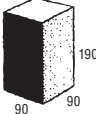
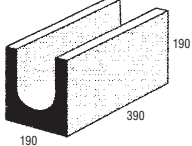
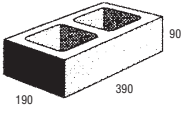
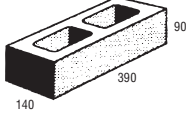
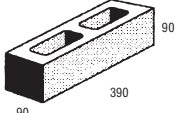
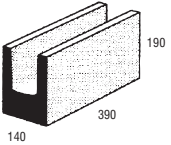
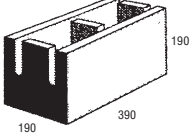
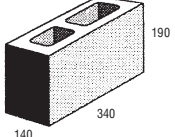
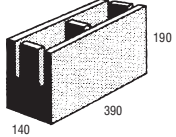
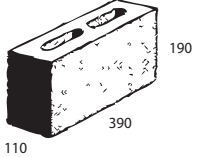
			
20.42 CHANNEL	15.42 CHANNEL	10.01 STANDARD	30.48 "H" BLOCK
			
20.02 THREE-QUARTER	15.02 THREE-QUARTER	10.02 THREE-QUARTER	30.18 LINTEL
			
20.03 HALF	15.03 HALF	10.03 HALF	15.48 "H" BLOCK
			
20.04 QUARTER	15.04 QUARTER	10.04 QUARTER	20.12 LINTEL
			
20.71 STANDARD	15.71 HALF HEIGHT STANDARD	10.71 HALF HEIGHT STANDARD	15.12 LINTEL
			
20.20 KNOCKOUT BOND BEAM	15.22 SEVEN EIGHTHS CLOSURE	15.20 KNOCK-OUT BOND BEAM	12.01 STANDARD

NB: Other sizes available. Please contact us to discuss your needs.



### QUALITY AUSTRALIAN MADE BLOCKS AND PAVING

9 Abbots Road, Dandenong South, VIC 3175  
 Phone: 03 9706 4426 Fax: 03 9706 4428 Mobile: 0408 561 598  
 Email: rad@eaglemasonry.com.au Web: www.eaglemasonry.com.au

FOR ALL ORDERS AND ENQUIRIES CALL 03 9706 4426

EAGLE MASONRY